

MAGNETIC RECORDING OF FLIGHT TEST DATA

by

G. E. Bennett, B.Sc., Ph.D., F.Inst.P.,
Instrumentation and Ranges Department,
Royal Aircraft Establishment,
Farnborough, Hampshire,
England.

SUMMARY

After starting with an assessment of the general requirement for a flight test data acquisition system, following with a general discussion of the complete system, the paper is subsequently concerned with some of the more important individual functions of the system - their nature and implementation. The functions selected are those most intimately involved in determining the performance of the system and its efficiency in acquiring the data. In the case of the recording aspects emphasis is placed on the basic recording process, its capabilities and its problems, and on the techniques necessary to overcome its shortcomings. Basic design principles of airborne tape transports and the characteristics of write/read heads and magnetic tape are also discussed.

The paper concludes with a discussion of the problems involved in specifying a requirement for a flight test data acquisition system and with comments on the likely nature of future systems.

1. INTRODUCTION

The magnetic tape data acquisition systems considered in this paper are those primarily required for comprehensive flight testing in the development and acceptance phases of military and civil aircraft and for specific research projects involving experiments in flight. Their basic problems and many of their features, however, apply equally well to in-service requirements for data acquisition, popularly referred to as Aircraft Integrated Data Systems (AIDS). Both these activities present problems not normally found in data acquisition requirements outside the aerospace field, where space and weight limitations and extreme environmental conditions do not apply to the same extent. The complexity and advanced technological nature of the present-day military weapon system or civil aircraft also give rise to a vast quantity of relevant data from a variety of sources, often required to an embarrassingly high accuracy and invariably demanding complex data handling and reduction facilities.

The nature and extent of the requirements for flight test data acquisition may be gauged by reference to flight test systems for recent aircraft projects such as Harrier¹, Jaguar², 747³, Concorde⁴, CF-5A⁵ and Fokker F-28⁶. Attempts to define general requirements have also been made by Henney⁷ and Roberts⁸, whilst requirements for specific research activities have been described by Gugleta⁹ (for acoustical and vibration environmental studies, flutter and load tests), and by Rose¹⁰ (for stability and control experiments). This information, considered in the light of likely aerospace developments in the future, provides a good basis for deducing future requirements. Also, considered in the light of likely advances in instrumentation technology, it enables the likely nature and problems of future flight test systems to be determined.

The following general features may be deduced from these diverse requirements to provide a background for this paper:-

(a) The data sources - inputs to the recording system - can comprise virtually all known transducer techniques and types. The majority provide analogue voltages which, with or without preconditioning as appropriate, may have any full-scale value in the range of a few millivolts to a few volts, associated with a wide range of impedances. A significant proportion of these are, and are likely to remain, at the millivolt level - commonly referred to as low-level. Other sources, whose number is likely to increase, are inherently in a coded digital form provided by an aircraft digital system or by a digital transducer, whilst some consist merely of two states indicating on/off or the occurrence of an event (bilevel inputs). Finally, a small number of hybrid sources, for example, those in which the information is provided as a pulse duration or pulse repetition frequency, may be present.

(b) Three broadly defined frequency bandwidths of the data sources are discernible:-

Quasistatic - zero frequency to about 10 Hz, which generally applies to over 90% of the input parameters relating to aircraft performance, stability and control, flight control, navigation systems, engineering systems, etc.

Intermediate - zero frequency to about 200 Hz, which accounts for a few per cent of the input parameters principally relating to aircraft flutter and vibration.

Wideband - up to at least 10 kHz, which applies to vibration, noise, speech, etc.

With the increasing use of digital recording the distinction between the quasistatic and intermediate bandwidths is gradually losing its significance.

(c) The total number of data sources, as expected, varies greatly with the nature of the project for which the acquisition system is required. Two extremes may be ventured - about 50 for a specific research experiment and 2000 for a comprehensive flight test programme on a new aircraft. The quasistatic system for the Concorde preproduction aircraft, for example, accepts 1440 analogue and 400 digital inputs.

Of equal significance in the case of digital recording is the overall sampling rate which may be as high as 10^5 per second.

(d) Although various accuracy requirements are specified and claims made, it is seldom clear what the figures strictly represent, what the acceptable probability of occurrence is and which of the many possible sources of error are accounted for. However, whatever the interpretation of the quoted figures, it is clear that they present formidable problems in system design and application, especially in the case of a small, but significant, number of quasistatic parameters for which an overall error of 0.1 to 0.2% is frequently demanded. Even in the case of the permissible errors of about 1% and 5% generally quoted for intermediate band and wideband data respectively it cannot be assumed that they are attainable without due attention to system design and application.

(e) Environmental conditions, although again varying with the project, are invariably severe in at least some respects which may include space and weight limitations, ambient temperature range, humidity, torsional and linear vibration, altitude and acceleration. Specific conditions for a given requirement are normally quoted by reference to national specifications. In military applications extreme conditions, of ambient temperature, vibration and acceleration in particular, are the rule. Electrical noise, common-mode and otherwise, and the impedances of connecting cables present a further environmental hazard which can be particularly elusive because of its dependence on factors relating to the aircraft installation.

(f) In order to cope efficiently with the different phases of a test programme a comprehensive acquisition system demands considerable flexibility, especially in the choice of data sources and the rate at which each is sampled. Hence the current tendency is to provide programmed control of data formats.

The task presented by these features, together with their data processing counterpart, clearly calls for magnetic tape as the recording medium, accounts for the current widespread use of this medium and establishes its future use for many more years. It is equally evident that all known techniques for overcoming the deficiencies of magnetic recording require to be exploited to the full. This paper considers these techniques and their associated equipment, and the preparation and organisation of the data after specialised preconditioning and prior to the recording process. It is thus primarily concerned with the airborne acquisition and recording system and the recovery of the data in electrical form from the airborne tape; it does not consider the data sources and their specialised preconditioning or the processes, usually involving the use of a general purpose computer, variously referred to as data handling, reduction and processing. It is intended more for the flight test engineer than for the system designer, and aims to present and discuss the capabilities, limitations and problems of a magnetic recording flight test system, thereby assisting in the specification and utilisation of such a system.

The system is complex and has to be subdivided into component parts; the method adopted for this is derived from a general discussion of the complete system in the next section.

2. THE COMPLETE DATA ACQUISITION SYSTEM

The recording techniques required in a comprehensive data acquisition system, and their broad range of applications, are as follows:-

- (a) Pulse code modulation (PCM) or digital recording - for quasistatic data and some intermediate frequency and, possibly, wideband data. This provides the best means of overcoming deficiencies in the magnetic recording process.
- (b) Single-carrier frequency modulation - for intermediate frequency and wideband data; each data source is provided with a carrier which, after modulation, is recorded on its own on one track of the tape.
- (c) Multi-carrier frequency modulation - for intermediate frequency and wideband data; a number of carriers of different frequencies are provided, each being modulated by a data source and then combined and recorded together on one track of the tape.
- (d) Direct recording - for wideband data; no modulation process is involved.

Other techniques are available but not frequently applied. One of these is pulse duration (or pulse width) modulation (PDM) which broadly serves the same purpose as PCM but is generally regarded as being inferior.

The data bandwidths for which PCM is most frequently applied allow the use of time-division multiplexing (TDM) in which a number of data sources are sampled in a prescribed order and the resulting digital words recorded consecutively on one channel of the tape (which may comprise more than one track). In multi-carrier frequency modulation sharing of one track by a number of data sources also occurs - by the process of frequency-division multiplexing. In this way it is possible to record more data sources on a given tape than with single-carrier frequency modulation, but each suffers a restriction in bandwidth. These techniques and their limitations are discussed further in sections 9 and 10.

It is convenient at this stage to subdivide the overall system into four subsystems corresponding to (a), (b), (c) and (d) above. The principal functions to be performed in each of these subsystems, both during recording in flight and subsequently reproducing on the ground, are indicated in the block diagrams of Figs. 1 to 7. It is assumed that preconditioning, which will not be considered in this paper, of the outputs of all the analogue data sources has already been made and that all the analogue inputs to the system are voltages (each associated with a certain finite impedance) of either millivolt or volt level.

These functional diagrams are not intended to represent the nature of the packaging of the physical devices required to carry out the functions, nor do they necessarily represent the only possible sequence of events. In the latter connection, however, it is essential, in order to reduce aliasing errors (discussed in section 6.1), to perform the low pass filtering function before time-division multiplexing or modulation,

and an individual filter must usually be provided for each data source output which is subject to either of these processes.

The PCM subsystem will be considered first (Figs.1 and 2). When associated with time-division multiplexing, as is almost invariably the case in flight test data acquisition, the amplifying function may take place in individual devices, one per data source, or in a device shared between some or all of the data sources. Two possible sequences of events emerge - individual amplifiers, individual filters and multiplexing or individual filters, multiplexing and a shared amplifier. The first sequence has the advantages that both filtering and multiplexing take place at a high voltage level, even when some of the input sources are low-level, and that the amplifier input characteristics can be individually matched to the input source and its gain set to give a common full-scale output level for multiplexing. It has the disadvantage that an amplifier is required for each input parameter, with consequent increase in cost, bulk and power requirements. The second sequence suffers from the serious disadvantage, when low-level input sources are involved, that the filtering and multiplexing take place at low signal levels. Also, additional complexity is introduced by the need to adjust the gain of the common amplifier in relation to the full-scale outputs of its data sources, and, as only a relatively small number of gain values is practicable (unless an adaptive process is employed), flexibility in the input capability of the system is thereby reduced.

The shared amplifier must have a much wider frequency bandwidth than the individual amplifiers, and a short settling time because of the switching operations. Its input offset and gain stability requirements may however be relaxed, since errors resulting from these sources can be calibrated out by combining with the input parameters known voltage levels, including zero, and using their corresponding amplifier outputs for correction either before recording the data or in the data reduction process. The programme control function included in Fig.1 is intended to provide the gain control required when a shared amplifier is used. It also provides, in the multiplexing function, control of the sampling rate of each input source. This is discussed further in section 5.

When the number of input parameters of the subsystem is large the current trend is to arrange the analogue data sources in a number of groups (for example, a system with an input capability of 256 parameters could be arranged in 16 groups each of 16 parameters or 8 groups each of 32 parameters) and to provide a separate package, comprising the functions of filtering, amplifying, multiplexing and analogue/digital conversion, for each of the groups. These packages are then located as near as possible to the data sources they serve - hence the term 'remote data acquisition unit (RDAU)'¹¹ - and all controlled from a centrally located control unit.

A simplified schematic diagram of this grouped approach is shown in Fig.8. The serial output from each group is transmitted to the central location along one cable - termed a highway - with a consequent reduction, which may be of very significant magnitude, in the weight and cost of cable. Increased system accuracy also results by transmitting the data as digital pulse trains, which are less susceptible to electrical noise, and by reducing the loading of the data sources by line capacitance and resistance. This decentralised approach also contributes flexibility by providing a convenient option in the number of RDAUs employed. Carrying the approach to its logical extreme would result in a separate unit, providing all the functions up to and including the analogue/digital conversion, for each data source, located near, or even integral with, its source. This, perhaps combined with remote digital multiplexers for groups of data sources, has many potential advantages, but its adoption is at present prohibited by the size and cost of the functional devices.

The central control unit receives the serial digital outputs from n RDAUs along n highways, and also data which is initially presented to the subsystem in digital form or in a form (for example, frequency modulation) which requires specialised conversion. These inputs, after specialised processing as required, are combined in a digital multiplexer, and synchronising and parity information added. They are then converted into the particular format and encoding required for recording and transmitted in serial or parallel form along a highway to the tape transport. The unit also holds the programme required for control of the multiplexing sequence and the amplifier gains, and provides the address information to the RDAUs.

One further aspect of the PCM subsystem - the transcription function - deserves comment at this stage. Ideally the magnetic tape recorded in flight should be compatible with the general purpose computer used for subsequent data processing. Many factors in flight test data acquisition, discussed in section 13, make this ideal unattainable in most applications at the present time. This, however, is expected to change with the increasing use of an airborne computer to provide adaptive techniques and pre-recording data processing, but it is generally agreed that this desirable approach is unlikely to attain widespread application in flight test data acquisition for many years. In the meantime, data will be presented to the magnetic recorder continuously and at a constant rate, choice of recording format, encoding and tape width being determined by acquisition rather than processing demands. The recorded tape may therefore require transcribing, on the ground, to a computer-compatible tape which will cause no embarrassment in a large multipurpose computing centre. This may be done, together with other functions such as demultiplexing, with the aid of a small computer which may also perform some preliminary data processing.

The frequency modulation subsystems of Figs.3 to 6 are based on telemetry standards defined in the IRIG Document 106-71, which are widely accepted for magnetic recording. International standards are currently being devised by the International Standards Organisation. When both analogue and digital recording are required in one complete system a shared multitrack tape transport may sometimes prove advantageous. The concept of remote data acquisition, discussed for the PCM subsystem, also applies, where appropriate, to the frequency modulated subsystems. In particular, individual amplifiers, filters and modulators, located near to their respective data sources, would allow transmission of data to a central location in the less sensitive frequency-modulated form and would reduce problems in the interface between the data source and the amplifier. The translation and detranslation functions indicated in Figs.5 and 6, and described in section 9.2, provide a means of reducing error in the modulation process. They are not essential and are therefore not universally applied.

The functions briefly referred to in this section are considered in greater detail in the remainder of the paper, together with the equipment required to implement them, emphasis being laid on techniques,

performance and basic design considerations rather than on design detail. This is preceded, in the next section, by a treatment, which applies in varying degrees to all the subsystems, of the errors which arise in the interface between the data source and the system input circuit.

3. THE INTERFACE BETWEEN THE DATA SOURCE AND THE SYSTEM INPUT

3.1 System input conditions

As seen in section 1, the data sources may be analogue, digital, bilevel or hybrid. This section is concerned mainly with the first type. The fullest information on the data sources and their transducers, if any, or on the preconditioning, if this is not considered part of the system, is required if the optimum system organisation and performance are to be achieved. In addition to the more obvious information, such as number of inputs, their type and frequency bandwidth, the following is of special significance:-

(a) The full-scale output voltage of each transducer or preconditioner, and whether it is uni-directional or bidirectional. Also whether it is a single-ended signal, presented on a single wire which is referenced to a ground datum common to all signals, or a differential signal, presented as the difference signal between two lines each of which is referenced to a ground common to all signals.

(b) The source impedances and their unbalance, including the impedances of the cables used for connecting the source to the system.

(c) The common component of the potentials, with respect to the system datum, of the two leads of each transducer: the common-mode voltage.

Low-level signals must invariably be handled differentially since pick-up or cross-talk signals into a single-ended source would create major errors; these are largely cancelled out in the differential case.

The magnitude of the data source impedance in relation to the system input impedance affects the system performance by voltage division - the normal network function which determines the distribution of the data voltage across its own source impedance and the input impedance of the system. The source impedance (and its unbalance) also combines with the back current (and its unbalance) of the system input electronics, whether amplifier, filter or multiplexer, to give an error. For low-level inputs, in particular, these may have significant magnitudes, especially at high ambient temperatures and for high source resistances; they are discussed later in this section.

Common-mode voltages have many possible origins. An inherent common potential may exist between the output leads of a transducer and the system datum as, for example, may occur with a transducer incorporating a bridge network. They may also be generated by amplifier back-currents and switch leakage currents in the data source lead impedances. Common transient voltages result from the interaction between the switch drive and signal circuits and from the connection of the system to different common-mode levels at each input. Other origins relate to the system installation, for example, potential drops in the common or earth lead between the transducer and the system datum due to earth loop currents (including power currents in the airframe) and similar effects, or pick-up from the electrical environment by electromagnetic or electrostatic (capacitive) coupling.

The almost certain presence of these common-mode voltages in a flight test data acquisition installation makes it necessary to provide a differential amplifier and filter and to switch both signal leads of the transducer in a double-pole switch. Each electronic device which is liable to have a common-mode component in its input must be capable of rejecting this to a degree determined by the permissible error of the system. However, any practical device will convert, to some degree, the common-mode voltage into a differential error voltage in series with the genuine data signal. This error is a function of the input impedances, the back currents and leakage currents, and their unbalances. It is to some extent under the control of the system designer, provided he is presented with considerable information about the data sources and their interface with the system. But some of this information, for example, that relating to the installation, may not be precisely known and the system performance has then to relate to conjectures hopefully based on past experience.

3.2 Steady-state errors in the data source/system interface

These errors, which may also occur in interfaces within the system, arise from the common-mode voltage, the input circuit back-current (necessary to set up the correct dc conditions in the circuit) or leakage currents (in switches) and the input impedances, and from unbalances in these currents and impedances. They may be illustrated by a consideration of the circuit model shown in Fig.9 which represents a differential system of switches and amplifier. Only one transducer and one common-mode source are shown, the open contacts of the 2-pole, n-way switch being returned directly to the amplifier earth. V_t , V_c and V_a are respectively the transducer voltage, the common-mode voltage and the differential input signal to the amplifier. R_{t1} and R_{t2} are the transducer plus lead resistances. The input stage of the differential amplifier is represented by the input resistance R_a and its unbalance ΔR_a together with the back-current I_a and its unbalance ΔI_a .

One way of the switch in the OFF condition may be represented by a capacitance C_0 across the open switch terminals and the leakage current I_0 of the device, as shown in Fig.10. The ON condition of the switch may be represented by the impedance R_d . Fig.11 is the result of replacing the switch in Fig.9 by these equivalents, with:-

$$R_s = R_t + R_d$$

$$I = I_a + (n - 1)I_0 \quad (\text{amplifier back-current plus leakage current of } (n - 1) \text{ OFF switches})$$

$$C = (n - 1)C_0 \quad (\text{total capacitance across the } (n - 1) \text{ OFF switches})$$

and ΔR_s , ΔI and ΔC representing their unbalances.

If it is assumed that errors due to switch and amplifier offset voltages have been eliminated by a calibration procedure, that the amplifier input resistance R_a is very much greater than R_s , and that all the unbalances are small, then the differential input signal V_a to the amplifier in the steady-state condition (i.e. disregarding C and ΔC) is given by¹²

$$V_a = V_t + V_c \left[\frac{R_a \Delta R_s - R_s \Delta R_a}{R_a^2} \right] + I \Delta R_s + R_s \Delta I \quad (1)$$

V_t is the correct signal, its attenuation factor $R_a / (R_a + R_s)$, referred to in section 3.1, having been removed by making the assumption $R_a \gg R_s$. The second term represents the conversion of the common-mode voltage to a differential signal by the asymmetries present. The third and fourth terms are independent of the common-mode voltage and in practice may exceed the common-mode error. The magnitude of the errors may be illustrated by taking the following values, which might well occur in practice:-

$$\begin{aligned} V_c &= 5 \text{ V} \\ R_s &= 2000 \Omega ; \quad \Delta R_s = 200 \Omega \\ R_a &= 10 \text{ M}\Omega ; \quad \Delta R_a = -1 \text{ M}\Omega \\ I &= 100 \text{ nA} ; \quad \Delta I = 10 \text{ nA (for } n = 100) . \end{aligned}$$

The second, third and fourth terms are then respectively 0.2 mV, 0.02 mV and 0.02 mV, giving a total error of 0.24 mV or 2.4% of a full-scale input signal of 10 mV.

As a wide range of values of all the impedances and currents involved are possible and, as discussed in section 2, the system functional sequence can vary, this example should not be taken to represent a typical system. In practice, for example, the source resistance to the multiplexer is usually the output resistance of a filter. It should then be possible to ensure that the resistance in each lead in this interface is balanced and, if the filter circuit is an active element, the resistance could be made small. The error due to source resistance could then be smaller than in the example and would become more dependent on the ON resistance of the switch - although the latter may still be in the region of 500 Ω to 1000 Ω .

Whatever the specific circumstances, these error-producing effects present a major problem both in the design and in the application of the system. As all the errors result from asymmetry in the two halves of the differential system it appears that they could be eliminated in the system design by adding preset components to cancel the unbalances present. Such a procedure has serious limitations in practice. Because of the inter-relation between the system and its input devices, effective balancing would apply only to a specific set of circumstances. Also, the degree of improvement possible is limited because the parameters to be balanced vary with changes in the operating conditions; for example, the source lead resistances and the leakage currents and offset voltages of semiconductor devices vary with temperature. Furthermore, the procedure would reduce the reliability of the equipment and would create engineering problems associated with the provision of access to the preset controls.

Another possible amelioration is that loosely referred to as 'calibrating out' - the application of known input voltages to the system at intervals during its use in order to record the deficiencies. The attenuation error, or any standing error such as offset, may be reduced in this way. The procedure, however, is not universally effective and adds to the complexity of both the data acquisition and data reduction processes. Although these compensation and calibration procedures have their uses, if only as a last resort, it is clearly necessary that at all stages, in design and application, every effort be made to reduce source resistances, back-currents and leakage currents, to increase input resistances, and to achieve the greatest possible symmetry in the two halves of the system and its data sources. These aspects will be considered further when dealing with individual functions of the system.

3.3 Errors due to ac common-mode signals

These signals usually derive from the electrical supply at a frequency of 400 Hz and its harmonics. When the frequency bandwidths of the data are well below these frequencies the conversion of ac common-mode to a differential signal will not produce a direct error; it may however give rise to considerable aliasing error in the time-division multiplexing and modulation functions. An expression for the converted signal may be derived from Fig.11. Making the assumptions previously quoted in the derivation of equation (1), and the additional ones that $\omega C R_s \ll 1$ and that the amplifier input resistances may be neglected in comparison with the shunt reactance, the expression becomes¹²

$$j\omega V_c (C \Delta R_s + R_s \Delta C) \quad (2)$$

in which V_c is the ac common-mode voltage of pulsance ω (= angular frequency or $2\pi \times$ frequency) and the other symbols are as previously defined; j is the imaginary operator.

This expression may only be taken as an indication of the mechanism by which an ac common-mode signal is converted into an unwanted differential signal. In practice the situation is complicated by the fact that the shunt capacitance is increased significantly by components arising from cable, drive circuit and amplifier input capacitances. Whilst some of these are lumped, others are distributed linearly and non-linearly, throughout the system, and thus make the analysis of a practical system difficult, if not

impossible. However, the order of the effect may be seen by taking the values of R_s and ΔR_s used in the example of section 3.2, together with a peak ac common-mode signal of 5 V at a frequency of 400 Hz and a shunt capacitance of 500 pF (for $n = 100$) with an unbalance of 100 pF. The peak value of the converted differential signal is then 3.8 mV, which would certainly be an embarrassment in the case of low-level data sources.

The error voltage resulting from this conversion of an ac common-mode signal to a differential signal may be attenuated by connecting a capacitor across the two leads from the data source, at the system end (points X, Y in Fig.11), to form a low-pass filter with the resistance of the source and its connecting cable. The capacitor required is usually large and must be chosen carefully to avoid introducing an additional error into the system due to the filter response in the data bandwidth. The same effect may be achieved by locating the main data source filter at the system end of the connecting cable (points X, Y). Errors resulting from both dc and ac common-mode signals may also be reduced by use of the technique known as boot-strapping or guarding. In this technique, shown in principle in Fig.12, the common-mode voltage of the ON channel is used as the system datum, the latter being driven by some means or other by a generator having an output approximately equal to the common-mode voltage. Referring to the figure, the effective common-mode voltage now applied to the system is

$$\frac{1}{2}(V_a + V_b) = \frac{1}{2}(1 - \alpha)(V_1 + V_2) .$$

Thus the common-mode voltage is reduced by a factor $(1 - \alpha)$.

The technique adds to the complexity of the system and creates the additional difficulty of having to lift the switch drive logic signals, and other points of the system, from a ground datum to the new, controlled datum.

None of these techniques provides the ideal solution; they therefore do not eliminate the need to pay great attention, in system and installation design, to the basic characteristics of the error-producing effects.

4. AMPLIFIERS

Amplification, or attenuation, is invariably required for each data source to convert the wide variety of transducer or preconditioner output voltages to the full-scale input level of the analogue/digital converter or modulator. Regrettably this full-scale input voltage does not have a standard value, but is usually in the range of 1 V to 10 V with the datum at one end or at the centre of the range. An individual amplifier must be provided for each data source when time-sharing is not employed. Its input characteristics may then be matched to its source with, if necessary, the use of preset controls. With time division multiplexing, which is usually performed in a PCM subsystem, a choice exists between individual amplifiers operating as the first function in the system, and a shared amplifier, operating after the multiplexing function.

Two additional features, already referred to in section 2, are required in the shared amplifier - a frequency bandwidth and settling time consistent with its multiplexed input and a variable gain under the control of the multiplexing programme. Both of these demand careful consideration in the design of the amplifier if its performance in other respects is not to be impaired. Some of the amplifier performance requirements (such as offset, zero drift, gain drift and linearity) may, however, be relaxed, since these errors may be reduced by injecting known voltages, including zero, into the multiplexing programme. The outputs of these calibration channels are then used, during data acquisition (in the analogue or digital stage) or during data reduction, to correct the data channels. This process may not be economic, and in any case is not universally effective; it is thus reasonable to assume the same performance requirements for both the individual and shared amplifiers, except for the additional requirements of the latter. This performance must be consistent with the specified system performance with due regard to the fact that the amplifying function is only one of many error sources.

It is evident from section 3 that a balanced amplifier is essential, unless other techniques are adopted to deal with the common-mode requirements. A frequency bandwidth extending down to zero frequency is almost invariably required in all modulation subsystems. This may be achieved in a number of ways including the following and hybrid variations of them:-

- (a) chopper or modulator amplifier - using mechanical or semiconductor choppers, the amplifying section being ac-coupled and the output obtained after synchronous demodulation and smoothing,
- (b) ac-coupled amplifier with dc restoration,
- (c) direct-coupled amplifier with an auxiliary chopper amplifier for drift stabilisation,
- (d) direct-coupled balanced amplifier - in which low drift is achieved by careful balance of the sources of drift in each half of the amplifier.

The desire to avoid aliasing errors and the complication of switching or modulation operations provide a good case for the direct-coupled balanced amplifier, which is further strengthened by current developments in semiconductor components and integrated circuit devices. An analysis of this type of amplifier in the context of flight test data acquisition has been made by Smith and Norman¹³.

Some of the desirable factors in the performance of the amplifier have already been discussed in section 3, including a high differential input impedance, low back-current and the minimum unbalance in both. Other factors are: accurate gain setting and low drift, low offset voltage and drift, high common-mode rejection, adequate frequency response, low noise, good linearity, low output impedance and good stabilisation against supply voltage variations; the drifts apply to both time and ambient temperature variation (typically -40°C to +80°C).

In the range of instrumentation amplifiers currently available and physically suitable for flight test systems emphasis tends to be placed on a good performance with respect to some of these factors at the expense of others. This, coupled with the frequent introduction of new devices with improved performance in specific respects, prevents the compilation of a meaningful summary, and results in the manufacturer's literature being the only source of up-to-date information.

It may be stated generally that the best current commercial amplifiers have inadequate performance, in at least some respects, for the more exacting requirements of flight test data acquisition, particularly where a high accuracy is demanded from low-level data sources. However, this situation is likely to change gradually with the introduction of improved integrated circuit devices and precision resistors and the development of new circuit configurations exploiting these advanced components. For example, the recent introduction of monolithic dual junction field effect transistors, in which the two transistors are formed on one chip, provides the basis of a highly-matched amplifier input circuit, with consequent improvement in the drift characteristics and in common-mode errors, whilst maintaining a high amplifier input resistance.

5. MULTIPLEXERS

The multiplexing function applies to the PCM and PDM subsystems, although PDM is now seldom used in flight test data acquisition. In this section the multiplexer gates, their format and their control are discussed. Sampling rates and errors inherent in the sampling process will be considered in the next section.

5.1 Switch elements

Some of the important properties of a multiplexing switch, especially when required to operate at low signal levels, are: a low ON resistance, a high OFF/ON resistance ratio, a low offset voltage, low leakage currents, good isolation between drive and signal paths and adequate speed of operation with a high degree of reliability. Some of these relate to the interface and common-mode conversion errors discussed in section 3. For relatively large signals, or in the presence of a high common-mode voltage, a large dynamic range for linear operation and a high breakdown voltage are additional requirements.

Related to the speed of operation are the transient voltages generated as the switch moves from one position to the next, due to the connection of the switch to different common-mode voltages and to coupling with the drive circuit. These transients must decay to an acceptable level before the switch can be considered to have closed, and the time taken for the succeeding amplifier to recovery from an over-voltage must also be taken into account. It is thus desirable that voltage transients during switching be of a low amplitude and short duration.

Mechanical rotary switches and individually controlled relays possess many of these properties. They, however, are liable to generate relatively high noise signals, from mechanical or magnetic causes, and have an undesirably short life and low reliability. The rotary switch is also not well suited to producing the control signals necessary to synchronise the operation of other functions of the system, such as the analogue/digital conversion, with the multiplexer, and lacks flexibility in the order and speed of switching. One therefore turns to semiconductor switching elements which have adequate speed (in the region of 10^5 operations per second) and can be operated from a central clock generator provided in the system for many purposes. Four types are of interest: light-sensitive devices, bipolar transistors, junction field-effect transistors (JFET) and metal-oxide silicon field-effect transistors (MOS FET).

A semiconductor element energised from a light source appears to provide a good basis for a switch element since it can have a high ratio of OFF/ON resistance and is isolated electrically from its drive. It has, however, not found wide application in the present context, although much used in chopper dc amplifiers, perhaps because of the variability with temperature of its characteristics and its limited speed of operation. It also requires a complex mechanism to provide its drive commands.

Before the advent of field-effect devices the bipolar transistor was widely used, mainly in the configuration known as the Bright switch¹⁴. In this configuration two transistors, used in the inverted mode (reversal of emitter and collector electrodes) in order to reduce leakage current, are connected in series in such a way that the two offsets tend to cancel. Residual offset, due to mismatching of the transistors, may be further reduced by including a preset control in the circuit, but the effectiveness of this is limited by the variation of the relevant parameters with temperature. The bipolar switch also suffers from a low impedance, and hence high coupling, between the signal and drive circuits. An attempt has been made to overcome some of these defects by combining the two transistors in one device - the double emitter transistor - but this appears not to have found much favour.

The use of field-effect devices¹⁵ has been enhanced by gradual improvements in their characteristics and by the manufacture of integrated devices. The p-channel MOS FET device, in particular, now provides the designer with a much more versatile analogue switching element which is currently widely applied in flight test data acquisition. The inherent offset of the device is very low and the dc isolation between drive and signal paths is high. Reasonable, though not low, ON resistances are achievable and the OFF resistance is inherently high. Leakage currents and overload requirements still create problems.

In circumstances involving low-level signals, high source resistances and common-mode voltages careful attention must be paid to both leakage currents and ON resistance if the errors discussed in section 3 are to be kept under control. Many of the characteristics of the MOS FET device create difficulties in this respect. For example, an inherent property of the device is that a change in the ON resistance is always accompanied by a change in the reverse direction in the leakage current. The performance of the device also deteriorates rapidly with increase in temperature. The ON resistance (usually in the region of 1 k Ω at 25 $^{\circ}$ C) increases by about 0.4% per $^{\circ}$ C, and the leakage currents (of the order of 100 pA per device at 25 $^{\circ}$ C) approximately double in value for each 10 $^{\circ}$ C rise in temperature. The situation is further complicated by the wide spread, in practical devices, in the values of all the characteristics and by the paucity of manufacturer's data. In these circumstances it is evident that

the design of a multiplexer presents major problems if it is to function satisfactorily in the adverse conditions prevailing in flight test data acquisition.

The properties of a MOS FET device as an analogue switch are enhanced if a number of similar devices are produced in close proximity on one silicon chip. In this way, closer matching of the characteristics is achieved in manufacture and the differential effect of ambient temperature is reduced. Integrated circuit chips are now available containing many MOST devices (for example, 16, providing 8 two-pole switches) together with their address coding and drive circuits. Even with the best of these devices, however, multiplexing at low signal level (10 mV, for example), in the presence of high source resistances and common-mode voltages, is likely to be accompanied by unacceptably large errors.

A useful review of FETs as analogue switches is given by Givens in *Electronic Components*, 26 January 1973. It also contains a reference to a recent development - an integrated combination of n-channel and p-channel devices on a common substrate known as complementary MOS (CMOS).

5.2 Multiplexing configurations

The errors resulting from the flow of the leakage currents in the data source resistances may, to some extent, be controlled by arranging the individual switches of the multiplexer in single or multi-tier configurations. Single and 2-tier configurations are illustrated in Fig.13, in which only one pole of each of the 2-pole switches is shown, its leakage current flowing to a common, earth line shared by all the transducers. In the 1-tier configuration each of the M inputs is connected through a single switch to the output point. In the 2-tier configuration the M inputs are arranged in n groups each comprising m inputs. Each of the n groups is treated as a 1-tier configuration and the n outputs so provided are each associated with a second switch which connects the group to the output point.

Assuming that the leakage currents are the same in the ON and OFF states of the switches, there are M units of leakage in the 1-tier arrangement. In the 2-tier arrangement the number of OFF switches is $(m + n - 2)$ and the number of ON switches 2, giving $(m + n)$ or $(m + M/m)$ units of leakage, and $M = m \times n$. For a given value of M , the minimum number of units occurs when

$$m = n = M^{\frac{1}{2}}$$

and the minimum leakage is then $2M^{\frac{1}{2}}$ units.

Similarly, in a 3-tier arrangement the optimum configuration is given by

$$m = n = p = M^{\frac{1}{3}},$$

where $M = m \times n \times p$, and the minimum leakage is $3M^{\frac{1}{3}}$ units. For $M = 64$, and taking one pole only of the 2-pole switch, the optimum conditions are given in the following table:-

Number of tiers	Number of switches/pole	Number of leakage units
1	$1 \times 64 = 64$	64
2	$8 \times 8 + 1 \times 8 = 72$	16
3	$16 \times 4 + 4 \times 4 + 1 \times 4 = 84$	12

Clearly the 2-tier arrangement has a significant advantage over the 1-tier arrangement. The additional improvement gained by using 3 tiers is small in relation to the increased number of switches. In both cases the improvement is gained at the expense of series resistance since the signal goes through two switches in the 2-tier case and through three switches in the 3-tier case. Due attention must be paid to this, especially since the resistance of one switch is in the region of $1 \text{ k}\Omega$ and close match of a pair is unlikely because of the temperature dependence of the resistance.

Errors resulting from the interaction of the multiplexer and its input sources, and from common-mode signals, may also be reduced using the technique of boot strapping or guarding already referred to in section 3, provided the considerable additional complexity is accepted.

5.3 Multiplexer control

The simplest way of operating a multiplexer comprising nominally independent switching elements is to sample all the data sources sequentially at an equal and constant rate under the control, for example, of an electronic ring counter, thus providing the same effect as with a rotary mechanical switch. Some flexibility in sampling rates, within a fixed total sampling rate, may be provided by supercommutation or subcommutation. In the former the sampling rate of a particular data source is increased by connecting it to more than one switch, these switches usually being spaced equally within the multiplexing frame (the smallest sampling pattern which is repeatable). A decrease in sampling rate may be obtained by submultiplexing, that is, by interposing a second stage of switching between the data source and the output highway and operating this at a different rate to, but synchronous with, that of the first stage.

Similar flexibility may be obtained by associating each data source with one and only one switch element (or two when double-pole switching is used) and providing supercommutation or subcommutation of the switch operating signals, for example, by cross-connecting the outputs of more than one ring counter position. An advantage of this method is that it requires less switch elements, the more critical components, to achieve a given degree of flexibility in the multiplexing pattern, at the expense of logic elements which are less critical. A further advantage is that drift and noise errors for a particular

data source may be more consistent, since with supercommutation in the switch elements successive samples from a particular source are transmitted through different elements. This type of multiplexing control is used in the Concorde prototype flight test system⁴ which has in effect a 3000-position ring counter to provide a frame containing 3000 'time-slots'.

The current requirement in flight test data acquisition is for programmed operation of the sampling rates of individual inputs, with a facility for quick and convenient change of programme at least on the ground between flights. Flexibility in the multiplexed frame pattern, with programmed operation, may be achieved using a resettable counter. The counter normally addresses switches sequentially in the conventional manner, its coded addresses being recognised by logic associated with each switch element. This sequence may be interrupted and the counter reset at defined positions according to instructions received from a store. Whilst the counter is free-running and operating the switches sequentially its output is also held in a register which already holds two instructions, received from the programme store, for the 'stop' and 'start' positions of the reset operation. When coincidence occurs between the counter output and the 'stop' instruction, the counter resets to the position defined by the 'start' instruction, and the next pair of reset instructions are transferred from the store to the register.

In practice only a limited flexibility can be achieved using a resettable counter. Complete flexibility may be achieved using a random access programme in which coded switch address information for each successive sample or time-slot in the multiplexer frame is held in a store and extracted sequentially by a counter operating in a conventional manner at the sampling rate. This method is assumed in the functional diagram of Fig.1.

The storage facilities required for these programmed multiplexers vary in complexity with the degree of flexibility required. In a simple system, or when infrequent programme changes are adequate, a plug-in card, hard-wired with a diode matrix, or some equivalent device, may be sufficient. A change of programme may then be achieved by exchanging the card for a new one or by removing the card and rewiring it. In a sophisticated system demanding much or complete flexibility, the address instructions may be held in, for example, a magnetic core store or a semiconductor store, into which they have been transferred from an external source, such as a punched paper tape or magnetic tape. An example of this is found in the Emmanual System¹⁶ which derives partial flexibility from a magnetic core store with a capacity of 2048 16-bit words.

It has been assumed thus far that the data sources are continuously energised and are connected to the highway by controlled switches in their outputs. Time-division multiplexing might also be achieved by pulsed energisation of the sources, where appropriate, whose outputs are permanently connected to the highway. This method is of limited application and presents many problems; it has not been applied to any extent in flight test data acquisition.

6. FILTERS AND ALIASING ERRORS

Whatever the method of acquisition and recording, filtering of the data signals may be desirable to reduce noise appearing on the data source output. Filtering may also be required to remove, from the transducer output, components outside the frequency bandwidth of interest, for example, when measuring aircraft acceleration, to remove components due to structural vibration from components due to the motion of the aircraft as a rigid body. In any sampling or modulation process, with or without time-division multiplexing, limitation of the data signal bandwidth is essential, and must be provided by electrical filtering, unless inherently provided in the transducer output by bandwidth limitations in the transducer itself or in the mechanism from which it derives its signal. Before accepting the adequacy of filtering external to the system, due consideration must be given to the possibility of secondary effects, such as secondary resonances, in the transducer or mechanism. Filters also play an important part in the demodulation process of frequency-modulation recording.

6.1 Aliasing errors

Any sampling process applied to a continuous waveform, with or without time-division multiplexing, is governed by the well-known sampling theorem which, in one of many forms, states that if a function $f(t)$ contains no components of frequency higher than F Hz, it is completely determined by its values at a series of points spaced $1/(2F)$ seconds apart over all time. Thus sampling an ideally band-limited waveform of bandwidth F Hz at a rate of $2F$ samples per second preserves all the information contained in the original waveform, and from the samples it is possible to reconstruct the waveform between sample points. If the waveform contains components at frequencies higher than half the sampling frequency (the Nyquist frequency), then the sampling process results in a downward spectral transposition of signal energy which produces an error in the components at frequencies less than or equal to F - a phenomenon known as aliasing.

Aliasing error is of particular significance in PCM, for which a high accuracy is normally expected, especially in flight test applications in which the lowest possible sampling speed is desirable and in which it is difficult to define, *a priori*, the signal bandwidth of interest. It also occurs in analogue modulation methods such as amplitude modulation (including modulation in an ac bridge)¹⁷ and frequency modulation. The ideal band-limiting demanded by the sampling theorem cannot occur in practice in any data source, nor can it be provided by a practical filter; errors are therefore inevitable, their magnitude being determined by the permissible sampling rate and the degree to which filtering may be provided to approach the ideal band-limited condition. The system design is usually a compromise, involving cost, size and accuracy, between sampling speed and filter complexity.

When a continuous record of the behaviour of the data source is required it is necessary to reconstitute the recorded samples into a continuous waveform - a process known as interpolation. This process results in an additional error whose magnitude is governed by the characteristics of the interpolation filter employed.

Several theoretical studies of these sampling errors have been made^{18,19}, all understandably based on a number of simplifying assumptions, such as the use of linear low-pass filters for the presampling

and interpolation filtering, and a sample duration tending to zero. In these studies the data waveforms are defined in terms of power spectral densities and the errors in root-mean-square terms. Sampling is regarded as a modulation process in which the data waveform modulates the otherwise constant amplitude of the sampling waveform which comprises a train of pulses at a repetition rate equal to the sampling rate f_s per second. The Fourier spectrum of such a series of pulses contains components at frequencies $0, f_s, 2f_s, \dots$, each associated with sidebands representing the original data spectrum. As long as the tails of the sidebands from adjacent carriers do not overlap, the original data can be recovered perfectly by simply passing the composite spectrum through a low-pass filter to remove the harmonics of the sampling frequency and their sidebands. However, if these sidebands do overlap, then the desired data spectrum (the upper sideband of the zero-frequency carrier) has added to it components originally from other frequencies, and aliasing occurs. Overlapping of the first sideband - the first order image spectrum - is illustrated in Fig.14 in which $P_d(f)$ and $P_s(f)$ are respectively the power spectral densities of the original data signal and the sampled data, and f_s is the sampling frequency.

The main contribution to the error results from the first image. As shown in the figure, the error has two components:-

- (a) Aliasing error: comprising those parts of the image spectra which lie within the bandwidth of the interpolation filter.
- (b) Distortion error: comprising the portion of the data spectrum and image spectra which do not lie within the bandwidth of the interpolation filter, and attributable to the fact that the filter transfer function is not unity.

Part of the distortion error occurs at frequencies outside the data bandwidth as determined by the presampling filter, and is therefore unlikely to be of interest. For a given sampling frequency the relative magnitude of the two error components is governed by the interpolation filter bandwidth. By increasing the sampling frequency the overlapping of the data spectrum images is reduced and a suitable choice of interpolation bandwidth then minimises the overall error.

The magnitude of the errors is determined by the sampling frequency and the roll-off characteristics of the data spectrum and the interpolation filter. Butterworth filters, discussed later in this section, are frequently used for interpolation and also for band-limiting the data before sampling. Aliasing and distortion errors under these conditions, for various orders of roll-off, are given by Reed and Lloyd¹⁹. The approximate conditions for aliasing errors of 1% and 0.1% rms are summarised in the following table, in which

- f_s = sampling frequency
 f_d = data filter 3dB bandwidth
 f_i = interpolation filter 3dB bandwidth
 n_d = order of Butterworth characteristic of data roll-off
 n_i = order of Butterworth interpolation filter

$\frac{f_s}{f_d}$	$\frac{f_i}{f_d}$	n_i	Value of n_d for an rms error of:-	
			1%	0.1%
4	1	4	6	U
		6	4	6
		Ideal	4	6
	2	4	U	U
		6	U	U
		Ideal	6	8
6	1	4	2 to 3	6
		6	2 to 3	4
		Ideal	2 to 3	4
	2	4	U	U
		6	3 to 4	U
		Ideal	3 to 4	5
8	1	4	2 to 3	3
		6	2 to 3	3 to 4
		Ideal	2 to 3	3 to 4
	2	4	3	U
		6	2 to 3	4
		Ideal	2 to 3	4

U = unattainable

The rms distortion component of the error, within the effective data bandwidth as previously discussed, is almost independent of the data cut-off rate n_d , as expected, and varies between 10% ($n_i = 2$) and 30% ($n_i = 8$) for $f_i/f_d = 1$, and between 1% ($n_i = 2$) and 3% ($n_i = 8$) for $f_i/f_d = 2$.

Both the aliasing and distortion components of the error may be interpreted in various ways. In data systems, for example, it is more usual to quote random errors relative to the peak-to-peak data signal, and not to the rms value. In that case the above results would have to be reduced by a factor dependent on the probability density function of the data amplitude - a typical value is a factor of about 5 for a Gaussian distribution (99% probability).

In some cases the time-averaged rms criterion for interpolation error can be very misleading; for example, in the zero order or 'boxcar' type of interpolation, where the output from the multiplexer is maintained by a 'hold' device until a step function is made to the next sample value. This type of interpolation is often quite acceptable for visual interpretation. The samples themselves accurately represent, apart from measurement error, the data values at the time they are taken, yet the time-averaged error in this case may be very high²⁰. Thus the significance of the rms error criterion can depend on the manner in which the reconstituted data is to be used. Where, for example, it forms the input to an analogue computer it is obviously relevant, but if the data is merely to be interpreted visually, it may not be so.

The above figures are based on the assumption that the band-limiting of the data is done entirely by the presampling filter. In practice there is usually some significant limitation of bandwidth before electrical filtering - by the transducer response, for example. Some knowledge of the data spectrum is therefore useful since in its absence it has to be assumed that the input is a random process having a flat power spectrum.

6.2 Types of filter

In order to limit aliasing errors it is evidently important to provide a high value of data cut-off rate n_d , not only to keep the sampling frequency low but also to make the use of high order interpolation filters really effective. This is an embarrassment in flight test data acquisition because of the low data frequencies usually of interest, the large number of filters required and the desire to keep the size of the equipment small. Other filter requirements include a constant amplitude response and constant or zero phase-shift in the pass-band, and characteristics which do not produce excessive errors of the type discussed in section 3. These latter requirements have to be satisfied over a wide temperature range.

Simple RC filters on their own seldom have an adequate rate of cut-off unless high sampling speeds per cycle are permissible. Active filters, in cascade, must therefore be provided, and critical attention paid to their many detailed characteristics which can produce errors other than aliasing error. The choice of basic type and of specific configuration is very wide, but the two types which share the greatest application are:-

- (i) The Butterworth filter, which provides a maximally flat amplitude response in the pass band and a sharp roll-off above the cut-off frequency. Ringing, due to overshoot in the response, may be severe for high order filters.
- (ii) The Bessel or Thomson filter, which provides a maximally flat time delay (linear phase) with a less sharp roll-off.

The choice between these two is governed largely by the criterion adopted to define the performance of the overall system; for example, if the minimum mean square error is sought, phase response may be disregarded and advantage taken of the superior amplitude response and sharper roll-off of the Butterworth filter.

Filtering is clearly of prime importance in flight test data acquisition systems and can contribute significantly to the complexity, bulk and cost of the system. The obvious approach to reducing the problems it creates is to sample each input at a frequency much higher than the minimum demanded by the sampling theorem, but this creates a problem in the recording process unless the number of samples is reduced somehow before recording. Many schemes have been suggested for making this reduction. One currently receiving active consideration involves digital filtering. In this scheme the output of the high speed multiplexer is digitised and then demultiplexed, if time-division multiplexing has been applied, to provide separate outputs, in digital form, for each data source. Each of these outputs is then applied to an appropriate digital filter²¹, and the filtered outputs, now corresponding normally to the data bandwidths, combined as required in a digital multiplexer, prior to recording.

This method has the potential advantage of providing the required filter characteristics by the use of digital operations and components, but is complex in its implementation. Developments in digital techniques and large scale integration are expected to make this complexity more manageable in the future. The method has not yet been widely applied in flight test data acquisition, although digital filtering of inputs already in digital form is currently in use^{22,23}.

6.3 Adaptive sampling²⁴

The above method of reducing data filtering problems is reminiscent of the more general technique of data compression which is an adaptive process for recording (or transmitting, in the case of telemetry) sampled data at rates consistent with the frequency bandwidth of the data source. Data compression has an obvious advantage in telemetry transmission where system efficiency is of paramount importance, as in space vehicles. It also provides a means of reducing aliasing error in the PCM subsystem of a flight test data acquisition system without severe filtering requirements and without creating excessively high pulse rates, and therefore a need for a large capacity, for recording.

It may be achieved in two ways:-

- (a) by adaptive sampling; controlling the rate of sampling of the data source in harmony with the frequency bandwidth of the source,
- (b) by redundancy reduction; sampling at a fixed rate of a sufficiently high value to avoid significant error in the data at the highest expected frequency, and eliminating from the multiplexer output data samples which can otherwise be specified.

As a result of data compression, the significant data source samples will be recorded at irregular intervals and, provided they are adequately identified, they may be presented in this form to the analyst or to a computer which, if required, can provide a reconstructed presentation. Account must be taken of sample identification when evaluating the bandwidth reduction characteristic of a redundancy process; the sample compression ratio will always be greater than the bit compression ratio.

In adaptive sampling, control logic analyses continually each input parameter to establish the instantaneous information bandwidth, and provides suitable output signals to control the operating frequency of an analogue gate in accordance with the bandwidth and accuracy requirements of the input parameter. The samples provided by the analogue gates of all the input parameters are then multiplexed in the normal manner, a buffer being provided on the output of each gate to permit sequential multiplexing of time-coincident samples from several input parameters. The critical function in this method is evidently that concerned with establishing the 'instantaneous' information bandwidth.

Similarly, in redundancy reduction the practical difficulty is in the selection of a suitable criterion which can also be implemented without undue equipment complexity. Redundancy exists whenever the variation of the data can be represented by a known law within predetermined error constraints. Such a pattern can be a mathematical expression or any arbitrary pattern based on experience. Recognition of a redundant sample can be achieved by prediction or interpolation. The predictor estimates the value of the next sample from previous readings. If the actual succeeding sample is equal to the estimated value within a predetermined tolerance, then it is discarded as redundant. For example, in the zero-order predictor the predicted value of the next sample is estimated to equal the previous non-redundant sample. In the interpolation method all the sample values between the last recorded value and the present value affect the interpolation. In the zero-order interpolator, for example, the sample used to represent a non-redundant reading is the average of the most positive and most negative values of all redundant samples since the last recorded sample.

The implementation of these adaptive techniques clearly involves considerable additional complexity in the system, and presents the difficult problem of deciding on a suitable criterion on which to base the compression process. The techniques have already found wide use in space vehicle telemetry, where compression is a considerable advantage, and in magnetic recording systems for operational data (AIDS). Scheinmann²⁵ describes a flight test experiment of limited scope, in which the performance of a data compression system was compared with that of a conventional galvanometer recorder. Good agreement and the attainment of a compression ratio of 38 to 1 are claimed, but this figure needs interpretation in relation to the specific conditions of the experiment.

Adaptive compression techniques have not yet been used to any significant extent in flight test data acquisition, but they deserve consideration in conjunction with other methods of achieving at least some of the desired results without an adaptive process.

7. ANALOGUE/DIGITAL CONVERTERS

The analogue/digital conversion function is required only for the analogue inputs of the PCM subsystem. It may take place in one physical unit centrally located or in a number of remotely located units the outputs of which are transmitted along digital highways to a central location, where they are digitally multiplexed.

7.1 Characteristics

Three characteristics require consideration:-

- (a) the digitising time, which determines the maximum number of conversions per second;
- (b) the aperture time, which represents the ability of the converter to deal with a changing input signal;
- (c) the steady-state performance of the converter in the specified ambient temperature range.

In the general case the input to the converter comprises a sequence of samples derived from a number of data sources each having a specific bandwidth, and hence a specific sampling rate. If a system has M sources of bandwidth f_m Hz ($m = 1$ to M) and each is sampled at x_m per cycle, then the maximum sampling time (assumed constant for all samples) is given by

$$T_s = \left[\sum_{m=1}^M x_m f_m \right]^{-1} \text{ seconds .}$$

The actual sampling time is less than this because of the finite mark/space ratio of the switch. The digitising time - the time available for the digitising process - is, in turn, less than the actual sampling time because of the transients introduced in the switching operation which must be allowed to decay to an acceptable level before conversion commences.

The aperture time T_a of a converter is the maximum time which may be allowed for digitising a data sample to the specified accuracy when the data source is varying with time. The 'worst case' value occurs when the signal is sampled at its maximum gradient point which, for a sinusoidal signal, is at the zero cross-over point when the peak-to-peak amplitude is equal to full-scale. Taking a sinusoidal signal of frequency f Hz under these conditions, and allowing a change of one least significant bit during the conversion time in a converter for which n binary bits represent full-scale, the aperture time is given by

$$T_a = \left[\pi f (2^n - 1) \right]^{-1} \text{ seconds} . \quad (3)$$

It may be argued that this 'worst case' approach is unnecessarily severe and that a longer aperture time can be allowed without serious deterioration in accuracy. Whilst this may be the case in some circumstances, for example when the interpolation procedure discussed in section 6 is involved, it is still considered to be a wise precaution to eliminate risk of error by designing for the worst case.

When the combination of data bandwidth and accuracy creates the need for a short aperture which is difficult to provide, a sample-and-hold technique may be applied at the input to the converter. The additional circuits then introduced, however, contribute to the steady-state error of the conversion process, especially in a varying temperature environment; they must therefore be applied with caution.

It is often assumed, wrongly, that the only error in the conversion process is the so-called quantising error, and that this has a value of $\pm \frac{1}{2}$ LSB (least significant bit). The accuracy of conversion is analysed for various conversion techniques by Lowe²⁶ and the conditions necessary to limit the quantisation error to $\frac{1}{2}$ LSB discussed, together with additional steady-state analogue errors resulting from the following:-

Zero shift within the converter - e.g. comparator offset.

Change in the overall scale factor - e.g. in the reference voltage or in the scaling resistor networks.

Non-linearity of the transfer characteristic - change in the weight the converter allocates to one bit without affecting the remainder.

Noise voltages generated within the converter.

All these effects are highly temperature-dependent and are therefore of special significance in an airborne converter. Noise and non-linearities cause the change point (the analogue input to just cause a change in output) to vary randomly, thus in effect changing the resolution of the converter. Often resolution is more important than absolute accuracy and it becomes important to keep noise and non-linearities to a minimum. A restriction on the permitted magnitudes of these effects may be set by specifying that the converter be monotonic. A converter is said to be monotonic if, when the input voltage is changed in either direction, all possible digital numbers appear in the correct sequence at the output, and no states are jumped. An incorrect sequence, or loss of digital states, would result from excessive noise voltages or non-linearities. Monotonicity, however, does not restrict errors due to gain or zero offset effects.

7.2 Conversion techniques and equipment

Conversion techniques and the performance to be expected from them are considered under three broad headings - analogue, feedback and analogue computer - by Lowe²⁶; the following is a summary based on this treatment.

Analogue methods involve an intermediate analogue-to-analogue conversion, for example voltage-to-time or voltage-to-frequency. In the former a time interval is made proportional to the input signal and the number of cycles of a fixed frequency occurring in this interval is counted. In the latter a frequency is made proportional to the input signal and the number of cycles occurring in a fixed time interval is counted. These converters have a relatively poor performance, especially in varying temperature conditions. Their digitising and aperture times, both equal to $(2^n - 1)\tau$, where n is the number of bits in a word and τ is the converter clock period, are very long, thus restricting their use to low sampling rates.

Feedback methods employ a digital-to-analogue converter, on which the accuracy of the converter largely depends. The digital-to-analogue conversion involves the generation of a series of suitably weighted analogue signals which may be added together in any combination to provide an analogue output representing, or having the weight of, any desired digital number. The basic method is best described by reference to the schematic circuit shown in Fig.15. An analogue input signal V_a is compared in the comparator with the weighting of a digital number held in the store. The comparator output supplies the control unit with information that enables it to adjust the digital number until the weighting of the number is equal to the incoming signal. The best-known implementation of this basic method is the successive approximation converter, in which the control unit of Fig.14 becomes a shift register which is used to programme the sequence of events. This converter is capable of a good performance and its digitising and aperture times are relatively short: $n\tau$ and $(n - 1)\tau$ respectively.

The above methods are all clocked systems in which each decision is initiated by a clock pulse. A continuous, unclocked process, which follows the input signal, is provided by the use of an analogue computer. This is most easily performed in the case of digital codes (e.g. pure binary or Gray codes) for which a simple set of generating equations exist; that is, equations which define the calculations required to convert an input signal into a form which will (a) provide information on the value of the most significant bit and (b) produce an output which may be treated as the input signal for the next calculation. The calculations required may be performed by a cascaded set of simple analogue computing elements, one per bit, the digital number being obtained by examining the output of each element. These

analogue computer methods involve several practical difficulties which do not apply to conventional clocked systems. Their digitising and aperture times are dependent on amplifier parameters in the analogue computers, and are difficult to evaluate.

Most commercial converters of small size and intended for airborne applications use the successive approximation method. The best currently available have digitising times in the region of 1 μ s, which is adequate for most flight test requirements, and aperture times in the region of 10 μ s. This aperture time, in the worst-case condition considered earlier (equation (3)), allows a change of 1 bit in a 10-bit full-scale for a signal of frequency 30 Hz approximately. Their temperature coefficient is at least 20 parts per million per $^{\circ}$ C which would contribute an error of $\pm 0.12\%$ in the ambient temperature range -40° C to $+80^{\circ}$ C. When assessing this error it must be remembered that even in the conversion function there is an additional, quantising, error of $\pm 0.05\%$ (in the above example), and that this function is only one of many in the complete system. It may therefore be stated safely that improvements in analogue/digital converter performance are essential to meet the most exacting requirements in flight test data acquisition.

One possible method of avoiding part of the steady-state error in a converter, and simultaneously in some of the other functions of the complete system, is to apply the ratiometer principle. Some data sources, such as potentiometric and bridge-type transducers, are energised from a dc supply and their output is in error if this supply changes in value. A more accurate measure of the physical input is provided by the ratio of the transducer output voltage to the energising voltage. The converter may be made to provide a digital output proportional to this ratio. This is done by replacing the built-in reference voltage, normally provided in the converter, by a voltage directly related to the transducer energising voltage. This process can be made to occur in the appropriate sampling periods by control from the multiplexing programme.

In this way errors resulting from instability in the converter reference voltage and the transducer energising voltage are, ideally, eliminated. Implementation of the technique is, however, an additional task of significant magnitude which, it may be argued, is not justified by the gain achieved. The same end might be more economically achieved by concentrating on providing adequate stability in the reference and energising voltages, or by recording these voltages and applying a correction during data processing.

8. THE MAGNETIC RECORDING PROCESS

The remainder of the paper is mainly concerned with the recording functions outlined in section 2. As an introduction, this section contains a resumé of the magnetic recording process and its capabilities, with emphasis on those features relevant to the data recording application. It is followed by accounts of analogue and digital recording methods and equipment, error sources in the magnetic recording process and data packing density considerations. Finally, tape transports, write and read heads and magnetic tape are considered.

8.1 General discussion

In magnetic recording as applied to flight data acquisition the storage medium is almost invariably magnetic tape, consisting of a plastic backing coated with a dispersion containing magnetic particles of relatively high coercivity. The writing (record) and the reading (playback or reproduce) operations are performed with multichannel transducers or heads, each element of which takes the form of a ring of low coercivity, high permeability material split at one point to form a narrow, non-magnetic gap and wound with one or more coils of fine wire. Conversion of the data to be recorded from a time to a space domain is achieved by moving the tape at a nominally constant velocity across the heads. Thus a signal of frequency f Hz is recorded with a wavelength λ which, for a relative motion of v m/s, has the value v/f metres. A representation of the overall process is given in Fig.16.

The head/tape relationship is illustrated in Fig.17. The tape always moves perpendicularly to the line of the gap. In the writing operation a signal current flowing through the head winding gives rise to a magnetic field H , the bulk of which appears across the gap where virtually the whole of the circuit reluctance is located. The tape, passing over the gap, is magnetised by the head gap fringing field and, since the magnetic particles of the coating are of high coercivity, some of the magnetisation is retained as remanent magnetisation after the tape has left the gap. In the reading operation, the recorded tape is passed in the same direction across the read head, when some of the flux from the elemental magnets will link the core of the head as these magnets cross the gap, because of the low-reluctance path provided by the core, and will induce voltages in the coil which are proportional to the rate of change of flux.

In the head/tape arrangement shown the direction of the magnetising force from the head and of the magnetisation in the tape lie along the tape and are parallel to the tape motion. This is known as longitudinal recording, although in the read operation it is the flux component emerging perpendicularly to the coating surface that provides the read signal. By suitable head design it is possible to magnetise the tape either perpendicularly or transversely, but these methods are seldom, if ever, used because of their inferior performance at short wavelengths, resulting from their inherently large gaps.

8.2 Analogue or linear recording

A simple and instructive relationship between the replay voltage and a sinusoidal write current may be derived if it is assumed that:-

- (a) the instantaneous magnetising force H applied to the tape is proportional to the instantaneous current in the write head;
- (b) the remanent induction B_r , and hence the remanent flux ϕ_r , at any point along the tape and available to enter the read head, will be proportional to the magnetising force;

(c) the recorded frequency produces wavelengths on the tape which are many times greater than the length of the read gap.

Under these idealised conditions the read output voltage for a write current $I \sin(2\pi f_r t)$ is given by²⁷

$$e = kI \frac{v_p}{v_r} f_r \cos \left(2\pi \frac{v_p}{v_r} f_r t \right) \quad (4)$$

where f_r is the recorded frequency, v_r, v_p are the record and replay tape speeds respectively, and k is a constant. It is evident that the replay frequency is $f_r (v_p/v_r)$ and that the process involves differentiation with respect to time.

The main extensive departure, in practice, from this ideal condition is the considerable divergence from linearity in the relationship between remanent induction and the magnetising force, as one might expect from the familiar $B - H$ and $B_r - H$ curves for the wide hysteresis loops of hard ferromagnetic materials. This non-linearity occurs mainly in the write operation, since essentially linear relationships hold for the low currents and voltages involved in the read operation. A linear relationship, when required, may be achieved by combining with the data current a bias current, preferably alternating, as will be discussed in section 9.

In digital recording linearity is usually of little account since one is concerned only with the presence or absence of a saturation transition, although linear digital recording has advantages and will be discussed in section 10. The frequency characteristic of the write/read operations is, however, relevant to both analogue and digital recording. According to equation (4) this characteristic rises with frequency at a constant slope of 6 dB per octave. In practice there are departures from this, at both ends of the characteristic, which are accounted for by various loss factors.

The departure at low frequencies (long wavelengths), significant mainly in direct recording, is a change in the constant slope of 6 dB per octave to a steeper slope and slight waviness in the characteristic. The change in slope arises when a half-wavelength recorded on the tape is longer than that portion of the tape which is in contact with the face of the head and is due to the fact that not all the lines of flux associated with the half-wavelength are linked with the read head. The waviness arises from the discontinuities at the sharp edges at the ends of the head face which produce so-called secondary gap effects. The wavelengths at which these effects set in may be raised by increasing the head/tape contact and by avoiding sharp edges in the head contour²⁷.

The loss factors at short wavelengths (high frequencies), occurring in the read operation, are of greater significance. They are briefly as follows, in which the symbols are defined in Fig.17 (the head in this case being the read head):-

(i) Gap loss

This is analogous to the aperture effect in photographic sound-on-film recording. When a sinusoidal variation in magnetisation in the tape is being scanned by a read gap which is very small compared with the recorded wavelength, the output voltage corresponds virtually to instantaneous values of the recorded magnetisation and the sinusoidal variation is virtually reproduced in the output. However, as the read gap length increases in relation to the recorded wavelength an averaging effect occurs. When the gap is equal to half a wavelength the output corresponds to $2/\pi$ times the peak of the recorded magnetisation; as the gap increases beyond half a wavelength, the averaging begins to include the opposite polarity of the second half cycle and the output further falls off rapidly, becoming zero when the gap length is equal to one whole wavelength.

The attenuation factor for this so-called gap loss, in its simplest form, is

$$\frac{\sin(\pi g/\lambda)}{\pi g/\lambda}, \quad (5)$$

giving null points in the response for $g = \lambda, 2\lambda$, etc. Westmijze²⁸ has derived a more accurate expression which gives the first null point for $g = 0.89\lambda$, thus making the effective gap-length about 1.12 times its physical length, a difference which has no great significance in practice because of the large tolerances in physical gap-length. Between the null points the response rises to a maximum, each successive maximum being lower than the previous one, the rate of fall being about 4 dB per octave.

(ii) Separation loss

This is due to the extremely short excursions of the lines of flux from the tape surface as the wavelength decreases, the critical separation thus being in the read operation. The attenuation factor is²⁹

$$\exp(-2\pi s/\lambda) \quad \text{or} \quad 54.6s/\lambda \text{ decibels} \quad (6)$$

(iii) Thickness loss

On the same basis as for separation loss it is reasonable to expect that as the wavelength decreases the inner layers of the tape coating take a decreasing part in determining the external field and hence the playback voltage. The attenuation factor is²⁸

$$\frac{1 - \exp(-2\pi t/\lambda)}{2\pi t/\lambda} \quad (7)$$

(iv) Azimuth and mistracking losses

These losses, due to equipment imperfections, occur in recording systems in which separate write and read heads are used. Azimuth loss occurs when the write and read gaps are not identically inclined to the line of tape motion. The attenuation factor is³⁰

$$\frac{\sin(\pi w \tan \alpha / \lambda)}{\pi w \tan \alpha / \lambda} \quad (8)$$

where w is the track width and α the misalignment angle. For small values of α the characteristic of this loss is similar to that of the gap loss (expression (5)). In multitrack heads, with necessarily narrow tracks, manufacturing tolerances may usually be set to keep the attenuation to an acceptably low value except at very short wavelengths when an azimuth adjustment of the read head may be necessary.

Mistracking loss, due to the incorrect location of the read head relative to the recorded track, may be avoided by using a narrower head for reading than for writing.

(v) Eddy current and hysteresis losses in the heads

These are the effects normally found in a magnetic device and are a function of frequency rather than wavelength. They will be discussed in section 14.

The gap, separation and thickness losses are illustrated in Fig.18, together with the nett response characteristic. The practical significance of the gap effect will be discussed in section 14. The critical nature of the head/tape separation is illustrated by the following example. The highest frequency currently claimed for wideband direct recording is 2 MHz at a tape speed of 304.8 cm/s, giving a wavelength of about 1.5 μ m. The first null in the response thus occurs at a gap-length $g = 0.89\lambda = 1.3 \mu$ m, and a separation loss of 5.46 dB results from a head/tape spacing of $0.1\lambda = 0.15 \mu$ m, which is considerably less than the wavelength of visible light.

It is evident from the foregoing that in the process of linear recording the read operation is reasonably well understood. This is not the case for the write operation, although many studies have been made in recent years, encouraged by the interest in increased packing density and in video recording. Outstanding problems include a better understanding of head/tape spacing and tape thickness effects, demagnetisation effects and high frequency bias, and a determination of the correlation between the magnetic properties of the head and tape and the recording performance. These are discussed in Refs.31 to 34.

8.3 Digital recording

In binary digital recording the write head current is a pulse waveform, usually capable of producing tape saturation in either direction. Ideally therefore there are two well-defined and easily reproducible magnetic states, as shown in Fig.19. In practice one cannot provide or record a perfect step function, nor can the read head produce an exact derivative of the tape magnetisation. The transition in the magnetic state of the tape thus occupies a finite length on the tape, as shown in the figure.

The basic read signal characteristic is an output pulse for each step change in magnetisation. The peak of this voltage pulse is roughly coincident with the passage of the magnetisation transition over the centre of the head gap. Its trailing edge generally falls off more gradually than the leading edge because of the electrical time constant of the read head coil. The reproduced voltage from a sequence of transitions (a recorded binary pattern) is alternating in character, in step with the alternate positive - and negative - going transitions (Fig.19).

The nature and characteristics of these reproduced patterns of binary voltage pulses may be studied either in the frequency domain, after performing a Fourier analysis on the complex encoded waveform, or in the time domain, by deriving the outputs of recorded pulses or step-functions and combining them by algebraic superposition.

An example of the first method, applied to various encoding patterns, is given in Ref.35. Again, far-reaching assumptions have to be made regarding the nature of the stored magnetisation pattern, but once these are made the various loss factors in the read process, quoted above, may be applied to each term of the Fourier series. An additional loss now considered is that due to demagnetisation in the write process, which occurs whenever the polarity of the write field is reversed. This effect is claimed by Morrison³⁶ to be the main factor in degrading digital recording; at high packing densities it extends the length of the recorded transition to such an extent that a sinusoidal distribution results.

Using the second method, various expressions have been derived for the amplitude and width of the read pulse, which are the most characteristic parameters of the digital recording process. Their dependence on the magnetic properties of the recording medium, its thickness, the medium-to-head spacing and the head characteristics has also been determined. The latest work based on the method is that of Speliotis and Morrison³⁷ which considers a magnetisation transition (under saturation conditions) of non-zero width in the recorded tape given by $\tan^{-1}(x/a)$, where a is the length of the transition and x is taken along an axis parallel to the tape motion with the origin at the centre of the transition. For a thin magnetic coating the expressions derived for pulse amplitude and width simplify to:-

$$e(\bar{x}) = \frac{k}{g} \left[\tan^{-1} \frac{\bar{x} + g/2}{s + a} - \tan^{-1} \frac{\bar{x} - g/2}{s + a} \right]$$

$$P_{50} = 2 \left[(s + a)^2 + (g/2)^2 \right]^{\frac{1}{2}}$$

where $e(\bar{x})$ = the amplitude of the pulse at distance \bar{x} from the centre of the transition
 P_{50} = the half pulse length
 g = replay gap width
 s = head-to-tape spacing
 k = constant.

The pulse amplitude is expressed as a function of x (tape speed times time) since the output voltage is inherently related to a distance measure rather than absolute time.

In these expressions the parameter g may be fairly accurately defined; the determination of s is more difficult and an attempt to determine the parameter a is made by Speliotis and Morrison. Theoretical and experimental results are quoted for recording surfaces of various metallic films with coating thicknesses of 0.025 to 0.9 μm . The record gap length is 3.75 μm , the replay gap length 1.0 μm and the tape speed 76.2 cm/s. The bit packing density is low enough to provide essentially isolated pulses, without interaction. Theoretical and practical results are in good agreement, the values of pulse amplitude and half width obtained ranging from 2 to 10 mV and 2.5 to 20 μm respectively.

General deductions of interest are: for thin recording surfaces the write process plays a minor part; demagnetisation is very important, which strongly implicates the magnetic parameters and the thickness of the recording surface in the resolution and amplitude of the read pulse: the head-to-tape spacing and the read gap are very important parameters; any one of the three parameters - transition region length, head-to-tape spacing and read gap length - can dominate the pulse width, depending on its size relative to the others.

In the above isolated transitions only have been considered, it being known for some time that, at low packing densities (less than 1000 flux reversals per cm), a good approximation of the multi-transition waveform may be obtained by linear superposition of the appropriate series of isolated transition output pulses. Since all the physical processes following the write operation can be considered linear, linear superposition should always be legitimate provided the magnetic transitions, as written, do not overlap. Mallinson and Steele³⁸ have recently shown that, at least for thin metallic media, linear superposition applies also at high packing densities, even where the written transitions overlap, provided some experimental conditions are met - the main ones being that rapid changes in the write head field polarity occur and that the bit interval is large compared to the head-to-tape spacing. The second condition is, in any case, necessary because of the severity of the spacing loss.

Superposition may be used to provide instructive illustrations of the phenomenon of pulse crowding which will be of interest when discussing bit packing density in section 12.3. In the read pulse pattern shown in Fig.19 each pulse is individually resolved, as is the case at low packing densities. At higher packing densities pulse crowding, or inter-symbol interference, occurs and this results in a reduction in the peak amplitude of the replay voltage, as illustrated in Fig.20. Fig.20a shows the write current and Fig.20b the read pulses at a low packing density where there is no pulse crowding; p is the distance between transitions and q is the read pulse width. As the packing density is increased adjacent pulses will overlap without, at first, affecting the maximum read voltage. But after reaching the position illustrated in Fig.20c, representing a packing density of about $2/q$, the maximum value of the read voltage will fall at a rate determined by the actual shape of the voltage pulses (Fig.20d).

Fig.21 illustrates the resultant output signal for a pair of saturation reversals separated by a distance p very much less than the pulse width q . The interesting effect produced by the pulse interference is a peak shift which causes a discrepancy in the pulse location with respect to a clock signal and may be of concern in high packing density recording.

Fig.22 illustrates the resultant output signal for three equally spaced saturation reversals separated by a distance p very much less than the pulse width q . Two related effects are seen - the central pulse suffers a greater attenuation than the other pulses and the resultant read signal has a shifted datum, that is it contains a zero frequency component.

9. ANALOGUE RECORDING METHODS³⁹

9.1 Direct recording

This term applies strictly to any form of recording with a nominally linear input/output transfer function and in which there is a direct proportionality between the magnetisation of the medium and the current in the record head or, more accurately, between the available flux for providing the playback voltage and the record current. In flight test data acquisition it has four possible applications:-

- (a) for recording, with modest accuracy, wideband data such as mechanical vibration and acoustic noise and, with a relatively narrow bandwidth, for recording speech;
- (b) for recording frequency-division multiplexed data, for which a linear transfer characteristic is essential;
- (c) as an alternative to saturation recording for PCM and wideband single-carrier FM recording, in aid of a high packing density;
- (d) on the ground, for predetection recording of the IRIG standard intermediate frequency signals in telemetry.

Linearising the considerable magnetic non-linearities discussed in section 8 is achieved with the use of a bias current in the record operation, high frequency bias being the more effective and thus universally used in data recording. It is applied by superimposing on the write current an alternating current of amplitude and frequency considerably greater than that of the data signal. Many explanations of its operation have been suggested³¹, none of which are fully satisfactory. Nevertheless the linearising effect

produced is considerable provided the bias frequency is at least three times the highest signal frequency and is free from even harmonics. The latter, because of the non-linear magnetisation characteristics, would leave a dc component of magnetisation on the tape which would increase the noise level.

System performance is critically related to the amplitude of the bias current and the maximum amplitude of the signal current, which together determine the compromise between low distortion, high output and high frequency response. Their optimum values are usually specified by the equipment manufacturer, but they vary with the type of tape and with head wear. A procedure to determine the optimum conditions is also defined by the IRIG document on telemetry standards⁴⁰, which involves adjusting the bias for maximum output at a specified frequency for each tape speed. The maximum data current is then adjusted for 1% total harmonic distortion (after equalisation) at specified frequencies, a magnitude considered to give tolerable cross-talk in frequency-division multiplexed FM recording.

The frequency characteristic of direct recording has been discussed in section 8 and is shown in Fig.18. The desired flat characteristic (a constant output/input ratio) over a wide range of frequencies is partially achieved using equalisation networks in the record and replay amplifiers. In data recording a constant flux level (with frequency) in the record operation is preferred, so that the equalisation in the record amplifier applies only where high frequency losses in the head would otherwise reduce the remanent flux. Equalisation is attempted for both amplitude and phase, but it is evidently a difficult process to implement accurately and cannot be strictly effective other than in the central region of the frequency range. A rather high value to the lowest frequency of the range is set by signal-to-noise ratio considerations.

The effect of tape speed variation (flutter) in the process will be discussed in section 11; it contributes to the amplitude noise and also produces timing or frequency errors, neither of which is reduced by equalisation.

Taking all these considerations into account, direct recording, on its own, cannot be expected to provide a very accurate method of recording. Signal-to-noise ratios are inevitably rather low and a variation of about $\pm 10\%$ must be accepted in the nominally flat amplitude/frequency characteristic.

The bandwidths currently provided in commercial direct recording systems are based on those defined in the IRIG Document 106-71 on telemetry standards⁴⁰. Four categories are defined, the extreme frequencies relating to the 3 dB points:-

Low band:	Six ranges extending from 100 Hz to 3 kHz (at 4.76 cm/s) to 100 Hz to 100 kHz (at 152.4 cm/s).
Intermediate band:	Seven ranges extending from 100 Hz to 7.5 kHz (at 4.76 cm/s) to 300 Hz to 500 kHz (at 304.8 cm/s).
1.5 wideband:	Six ranges extending from 400 Hz to 46 kHz (at 9.52 cm/s) to 400 Hz to 1.5 MHz (at 304.8 cm/s).
2.0 wideband:	Six ranges extending from 400 Hz to 62.5 kHz (at 9.52 cm/s) to 400 Hz to 2 MHz (at 304.8 cm/s).

Maximum signal-to-noise ratios currently quoted for commercial equipment are about 36 dB for the intermediate band and about 20 dB for the widebands.

The low band category is now generally accepted to have a modest performance and is therefore seldom adopted. The wideband frequency bandwidths, on the other hand, are certainly ambitious and rely on the availability of equipment (specially heads) of advanced and critical design, demanding an extreme degree of maintenance, especially under airborne conditions. They should therefore be used with caution in flight test data acquisition.

9.2 Frequency modulation recording

Frequency modulation provides a means of recording data containing frequency components (down to zero frequency) lower than the practical minimum frequency for direct recording, and is capable of substantially higher accuracy. These superior features also apply to pulse-code modulation, which is capable of an even higher accuracy. Hitherto, however, PCM in data recording has been limited to a maximum frequency in the region of 50 Hz per parameter by the performance of available digital components and because of the lesser complexity, and hence bulk and cost, expected of FM. Developments in the last decade in techniques such as analogue/digital conversion and in the digital magnetic recording process, aided by advances in integrated circuit devices, are changing this situation and there is already no indisputable reason why PCM should not be efficiently and economically applied to considerably higher frequencies well into the traditional FM range. However, tradition dies hard in flight test instrumentation, as is evident from the era of scepticism regarding magnetic recording, and the extended use of PCM is likely to follow the same gradual course of development.

In section 2 reference has been made to the two common variants of frequency modulated recording (single-carrier and frequency-division multiplexed, multi-carrier) and their system functions have been illustrated in Figs.3 to 6. The two variants will now be treated in somewhat greater detail and the standards, based on the telemetry standards in IRIG Document 106-71, generally adopted for their implementation summarised.

For the single-carrier system four categories are defined - low band, intermediate band, wideband Group I and wideband Group II. The first represents a very modest performance relative to the capability of present-day magnetic recording equipment and is seldom used; it is therefore not discussed. The principal features of each category are tape speed, carrier centre frequency, full-scale frequency deviation and modulation or data bandwidth (invariably extending to zero frequency). Tape speeds range

in a binary sequence from 4.76 cm/s to 304.8 cm/s, but not all the speeds apply to all the categories. Carrier centre frequencies and data bandwidth limits are proportional to tape speed and may therefore be specified in cycles/cm. A constant full-scale deviation (expressed as a percentage of the carrier frequency), irrespective of tape speed, is specified for each of the categories. On this basis the complete range of standards is summarised in the following table:-

Category	Full-scale deviation	Tape speed (cm/s)	Centre frequency (cycles/cm)	Data bandwidth (cycles/cm)
Intermediate band	±40%	4.76 to 304.8	708	131
Wideband Group I	±40%	9.52 to 304.8	1416	262
Wideband Group II	±30%	9.52 to 304.8	2952	1312

For the frequency-division multiplexed, multi-carrier system two sets of standards are defined - proportional subcarrier channels and constant bandwidth subcarrier channels. In the former all the channels have a full-scale deviation of ±7.5% of the centre frequency, with an alternative of ±15% for the upper 8 subcarriers. A total of 21 subcarriers (centre frequencies) are specified, starting at 400 Hz and increasing from one to the next by a factor of approximately 1.33 to the highest subcarrier of 165 kHz. Data bandwidth (for ±7.5% deviation) starts at 6 Hz for the 400 Hz subcarrier, and again increases by the approximate factor 1.33 to a maximum of 2475 Hz. In the constant bandwidth case all the channels have a full-scale deviation of ±2 kHz or alternatively, for some of the channels, ±4 kHz or ±8 kHz. Corresponding to these are three data bandwidths of 0.4 kHz, 0.8 kHz and 1.6 kHz. 21 subcarriers are specified starting at 16 kHz and increasing in steps of 8 kHz to a maximum of 176 kHz. Further variants of these, designated half-IFIG, etc., may be devised to meet specific requirements. The data bandwidths quoted for both frequency-division multiplexed systems are minimum values; Appendix B of IRIG Document 106-71 indicates how they may be increased at the expense of accuracy.

The respective roles of these variants of the multi-carrier FM system are self-evident. It is of interest that the constant bandwidth channels are arranged to have identical time delays. This is particularly valuable when computing cross-correlation in, for example, vibration data, and when tape skew would produce intolerable phase errors if the data from different tracks were compared.

The demands of these standards on the magnetic recording process may be deduced from the familiar theory of FM in the communications field. Briefly a frequency modulated voltage is expressed as

$$e = E_0 \sin (\omega_c t + m \sin \omega t)$$

which, with the aid of Bessel functions, may be written

$$\frac{e}{E_0} = J_0(m) \sin (\omega_c t) + \sum_1^{\infty} \left[J_r(m) \{ \sin (\omega_c + r\omega)t - \sin (\omega_c - r\omega)t \} \right]$$

in which ω_c = carrier pulsance = $2\pi \times$ carrier frequency f_c
 ω = data pulsance = $2\pi \times$ data frequency f
 m = modulation index ($\Delta f / f$)
 Δf_c = peak deviation of the carrier by the data.

Thus the frequency modulated voltage is represented by a carrier, the J_0 term, together with pairs of sidebands whose amplitudes are governed by the modulation index m . The minimum values, at peak deviation, of m for single-carrier and multi-carrier (proportional channels) are respectively 2 and 5.

The relative amplitudes of the sidebands may be found by reference to Bessel function tables, and the recording bandwidth determined in relation to noise and distortion⁴¹. This bandwidth cannot be expressed in precise terms but is always wider than twice the deviation. At the extreme condition, when the input is full-scale and the data frequency greatest, a total frequency bandwidth of about four times the deviation may be required to retain the sidebands whose amplitudes are more than 1% of the unmodulated carrier amplitude.

Except when the highest packing density is required, saturation recording is normally used for single-carrier FM in order to achieve the maximum replay voltage. Linear recording is used to attain the high packing density of wideband Group II FM. It may also be used to reduce cross-talk between adjacent channels, because then, as ac bias is present, the record current may be reduced by a factor of 5 to 10 without undue loss in replay voltage; it is essential if the adjacent track (in the same head-stack) is operating linearly, because of the sensitivity of ac bias to weak fields. Linear recording is also essential for multi-carrier FM in order to avoid the cross-talk between subcarriers that would otherwise result from interference between the harmonics of a low frequency carrier and the high frequency carriers. A major potential source of error in all the FM methods is tape speed variation (flutter), especially in the multi-carrier case where deviations are relatively small. Flutter compensation may be applied, but its effectiveness is limited in the single-carrier case by dynamic skew in the tape motion. These effects are discussed in section 11.

In the FM record electronics the common-mode and source impedance effects discussed in section 3 apply where appropriate and filters may be required to reduce aliasing error. The primary function of the electronics is, of course, modulation or voltage-to-frequency conversion, for which the important characteristics are linearity and low drift, with temperature, of the datum (centre frequency) and the sensitivity.

The main constituents of the demodulator or discriminator are a low-noise preamplifier, a limiting amplifier, frequency-to-voltage converter, flutter compensation circuit, low-pass output filter and output

amplifier. In the multi-carrier FM system the discriminator is preceded by a band-pass filter to select the appropriate channel from the frequency-division multiplexed signals; this is a critical component in which phase linearity is essential. The limiting amplifier must cope, symmetrically with respect to the zero axis, with the wide range of signal levels, microvolts to millivolts, possible from the replay head. Demodulation proper is usually a process of cycle-counting or integration of pulses of constant duration and amplitude. The latter is illustrated in Fig.23. Each positive-going edge of the FM carrier reproduced from the tape, after limiting, is used to trigger a pulse generator which provides pulses of constant width and amplitude. The pulse generator output is then integrated using a low-pass filter. Two types of output filter are normally provided - one with a maximally flat amplitude response and the other with a linear phase response (as discussed in section 6.2 for aliasing error reduction). The latter is used for complex signals or transients for which a constant time delay and no ringing are required. If flutter compensation is provided, close matching of the phase characteristics of the data and reference channel filters may be necessary.

In magnetic recording phase-lock loop demodulators, familiar in telemetry, are seldom used because of the greater emphasis placed on linearity rather than on the ability to operate at poor signal-to-noise ratios.

The achievement of a good accuracy and stability, especially over a wide temperature range, presents many difficult design problems in the pulse type discriminator. These problems occur mainly in the filters and the pulse generator. Also, in multispeed FM recording it is expensive to provide as many different pulse width and filter combinations as there are tape speeds.⁴² In an attempt to avoid these disadvantages digital discriminators have been developed. In a typical one⁴² the limited pulses of the reproduced FM carrier are applied to a period measuring circuit which generates a binary number proportional to the instantaneous period of the FM carrier. The inverse of this is then calculated to provide a linear transfer characteristic. There is thus a digital output for each carrier cycle which, if required, may be converted to an analogue output in a digital-to-analogue converter.

Typical performance figures for a single-carrier frequency modulated system (record and replay) are:-

linearity:	±0.5% full-scale;
drift:	±0.5% full-scale per degree C in the range 0°C to +50°C;
rms signal to rms noise ratios:	
intermediate bandwidth:	50 dB
wideband Group I:	45 dB
wideband Group II:	30 dB

Some corresponding figures for modulators only, of comparable input sensitivity, designed specially for airborne use⁴³, and illustrated in Fig.24, are:-

linearity:	±0.1% full-scale;
centre frequency drift:	±0.007% full-scale per degree C in the range -70°C to +70°C;
sensitivity drift:	±0.01% full-scale per degree C in the range -70°C to +70°C.

In both variants of frequency-division multiplexing the operation of translation and detranslation, included in the subsystem shown in Figs.5 and 6, is sometimes used. This is best described with the aid of an example. In a system comprising 15 subcarriers, f_1 to f_{15} , three identical sets of modulators with centre frequencies f_1 to f_5 are provided and modulated by the data. The outputs of set 1 are left unchanged; those of set 2 are translated in frequency to provide the subcarriers f_6 to f_{10} , and those of set 3 are translated to provide the subcarriers f_{11} to f_{15} . In the proportional subcarrier variant the final full-scale deviation of all subcarriers is ±7.5% (or ±15%), so that the initial modulation in the case of sets 2 and 3 occurs at a full-scale deviation greater than ±7.5%, thus making the process less sensitive to modulator drift provided the new frequencies introduced for the translation process have adequate stability. The same advantage applies to the constant bandwidth variant, but with greater relevance, since the specified deviations (as a percentage of the subcarrier frequency) are so small at the higher subcarrier frequencies. In the replay operation the reverse process is applied and, in the above example, three identical sets of discriminators used.

9.3 Other analogue recording methods⁴¹

With the increasing use of pulse code modulation these other methods are now seldom used in data acquisition and will therefore only be briefly discussed.

The main other method is pulse duration, or pulse width, modulation (PDM) which involves modulation, by the data amplitude, of the time spacing between the beginning and the end of a pulse. It is generally applied with time-division multiplexing as in the case of PCM, provides response to zero frequency and is capable of good linearity and an accuracy generally agreed to lie somewhere between that of FM and PCM. It is relatively insensitive to tape flutter over a wide range of frequency, provided there are no flutter components near the pulse repetition rate, and, like all time-division multiplexed systems, it is amenable to in-flight calibration. Its main disadvantages are a limited bandwidth, at a given tape speed, relative to FM and a lower accuracy capability than PCM.

PDM outputs may readily be converted to a digital representation before recording; hence the use of PDM as a basis for analogue/digital conversion⁴⁴. Each PDM pulse acts as a gate to pass a number of equally

spaced short-duration pulses, the number varying directly with the PDM pulse duration. These short-duration pulses are then counted in a digital counter.

An interesting and very simple method is carrier erase recording in which a carrier is prerecorded on the tape at saturation level. The current in the record head then acts to erase this carrier partially, an approximately linear transfer characteristic being obtained by using a bias current. The method is very sensitive to record current and can frequently operate, without amplification, from low-level transducer outputs. It, however, has some of the disadvantages of direct recording and suffers from hysteresis, and has therefore not been widely used.

Finally, compound modulation, a method with some appeal for recording the outputs of ac bridge transducers. The amplitude modulated bridge output is made to frequency modulate another carrier. This FM signal is then added linearly to the bridge excitation signal and both recorded linearly, with ac bias, on a single tape track. Phase relationships between the bridge excitation and its output sidebands are thus maintained for demodulation on replay.

10. DIGITAL RECORDING METHODS

10.1 Digital words and their recording formats

The straight binary notation is usually used in the PCM subsystem of a flight test data acquisition system; cyclic binary codes have no clear advantage. The use of higher radices, necessitating more than two individually recognisable states of magnetisation, is not a preferred means of increasing surface information density. A radix higher than two degrades the reliability of the recording process and demands more complex write/read electronics; it is thus generally considered inferior to the alternative methods, involving narrow tracks, narrow gaps and thinly-coated tape, for achieving the same purpose.

The possibility of drop-outs and drop-ins due to tape defects, dust, tape transport defects, etc., makes the use of an error-checking code desirable in data acquisition, particularly in an airborne environment. The most commonly used method is the parity check, often applied both longitudinally and laterally, and thus giving a means of locating some errors and achieving some degree of error correction. One or two parity bits are added to the recorded character and yield much for a nominal amount of redundancy or loss in tape utilisation. The complete sequence of bits to be recorded thus comprises data sample bits, parity bits and word and frame synchronisation and count bits as demanded by the system control arrangements.

A number of standards for data format on computer tapes have been in operation for many years. These are now embodied in recommendations of the International Standards Organisation⁴⁵ which specify 7 tracks on 12.7mm tape at 8 bits/mm and 9 tracks on 12.7mm tape at 8, 32 and 63 bits/mm. Data blocking is specified for all formats, with block lengths ranging from 18 to 2048 rows and interblock gaps from millimetres to metres. No standard exists for magnetic recording in airborne data acquisition, although the standard for track spacing defined in IRIG Document 106-71 for recording PCM telemetry signals on the ground is sometimes used. This applies to 25.4mm tape and a parallel format and defines two track configurations: 16-track in-line and 15 plus 16-track interleaved. New recommendations by the International Standards Organisation, which apply to both analogue and digital formats, are in preparation; these specify 7, 14 or 21 track on 12.7mm tape and 14, 28 or 42 tracks on 25.4mm tape. In each case a pair of head stacks, providing interleaved tracks, is specified. The computer standards are usually inappropriate because of their inefficient use of the tape surface area, especially as, in flight testing, the data is normally continuously generated.

In flight test data acquisition the tape with its multitrack head allows two basic formats for the bit configuration recorded on the tape surface - serial and parallel. In the serial format the bits associated with a particular data sample are recorded sequentially on the same track. One track may be used at any particular time and when this is completely recorded the write current is switched to the next track with the tape now moving in the reverse direction (a reciprocating tape transport) or in the same direction (a continuous loop tape transport). Alternatively, a number of tracks may be recorded simultaneously, each taking a sequence of words serially recorded. This alternative demands as many sets or write electronics as there are tracks in simultaneous use, or the use of a multiplexing operation. In the parallel format the bits associated with the data sample are all recorded simultaneously transversely across the tape, the number of tracks provided being equal to the number of bits in the word. A hybrid arrangement, called a series-parallel representation, involves the simultaneous parallel recording of part of the word (a character), the other part or parts following on serially.

The choice of format relates to the overall system requirements, record and replay data rates, data reduction requirements, tape width and speed, packing density requirements and reliability (or data security). The serial format clearly allows the greater degree of flexibility. A significant difference in the performance expected from the two basic formats is that tape motion imperfections, in particular dynamic skew (as discussed in section 11), and mechanical imperfections in the write and read heads, set a more severe limitation on bit packing density in the parallel format unless due attention is paid to data clocking, as discussed in the next section, and a deskew buffer is provided on replay.

A second important difference relates to the effect of signal drop-outs on the integrity of the recovered data from the two formats. As discussed in section 11, signal drop-outs on replay tend to occur in bursts located where there are tape defects or dust. An individual defect normally spreads over one or two tracks only, but, because of the high longitudinal packing density relative to the transverse packing density, the same defect spreads longitudinally over far more than one or two bits and a large number of consecutive bits along one track may be lost. In the parallel recording mode an equal number of consecutive words will be lost, whilst in the serial recording mode many consecutive bits along a track will belong to the same word so that only a relatively small number of words will be lost. Normally, in the serial mode the loss amounts to one or two words on each of one or two tracks. The data error rate of a serial system, resulting from this type of drop-out, is thus considerably lower than that in a parallel system, an advantage of increasing significance with increase in longitudinal data packing density.

10.2 Bit clocking; word and frame synchronisation

A vital process in digital recording is bit clocking in the read operation, that is, defining the location of each bit interval. Two basic methods are available - external clocking and self-clocking. The former relies on an external clock generator, the pulses of which are recorded in parallel with the data, to define each bit period. Self-clocking applies to reading methods in which the basic clock is derived from the data itself, that is, each recorded track clocks itself.

If external clocking is required in serial recording, a clock track must always be associated with a data track. In parallel recording with external clocking one additional clock track, located at or near the centre of the multitrack tape, is normally provided to cope with all the data tracks. In both series and parallel recording the successful use of external clocking depends on the degree of time synchronisation between the data and clock tracks, that is, on the differential time displacements between bits on the respective tracks due to tape motion irregularities and imperfections in multitrack heads (sections 11.2 and 14.1). The acceptable degree of time displacement error decreases with the duration of the bit interval, that is, with the bit packing density. External clocking therefore imposes an upper limit on longitudinal bit packing density with both series and parallel modes of recording. The latter case is considered quantitatively in section 12.5.

The generation of a clock signal from the reproduced data signal - self-clocking - is greatly helped by the existence of an output pulse during each bit interval. This regular output pulse permits resynchronisation of the clock signal once per bit interval. Otherwise the electronic clock generator has to free-wheel for a number of bit intervals, the clock and recorded data being, in effect, decoupled during this time. With self-clocking no limitation in bit packing density results from inter-track timing displacement, but for correct operation the method does demand a limited degree of bit-to-bit time displacement on the same track (bit jitter, produced by tape speed variation) because the time slot for a particular bit is generated by the electronic clocking circuit using the previous bit as a time reference. Also, in the parallel format, inter-track time displacement creates the need for a deskewing buffer in the reproduction process to hold the bits from each track until all those corresponding to the same word are available.

The presence of a pulse, on replay, in each bit interval is an important feature of an encoded waveform and will be discussed in the next subsection. In parallel recording the presence of a pulse in each word or character interval - to facilitate word or character self-clocking - may be ensured by coding the parallel-recorded character so that there is always at least one pulse present. Many coding systems with this property have been devised. Alternatively, an odd parity check bit may be used; that is, if the sum of the character bits is even (for example, all 'zeros' - no pulses) a parity bit of 'one' is added.

Ideally a time-division multiplexed PCM reproduced signal may be analysed into its constituent parts (words, frames and subframes) by counting bits from a datum and on this basis forming the words, subframes and frames of the input data. In practice this process must be assisted by recording synchronisation words at appropriate times in the data sequence and by paying special attention to these in the replay operation. Of particular importance are subframe and frame synchronisation and the provision of a reference for the deskewing operation, when applied.

The required frequency and make-up of these synchronisation words are determined from system considerations and by the degree of data security required in the presence of noise, drop-outs and tape motion irregularities. It is generally recognised that to provide adequate security of data at high packing densities a synchronisation word, made up of a number of serially recorded bits, must be interlaced with the data stream at least once per frame or even once per subframe for a long, complicated frame. These words may be composed with the maximum degree of uniqueness relative to all possible data words and detected on replay in a synchronisation pattern detector. Alternatively, and to reduce the vulnerability of the unique word to noise and drop-outs, pseudo-random synchronisation patterns may be used and decoded in a majority logic pattern recogniser⁴⁶.

In a comprehensive flight data acquisition system the synchronisation facilities must provide a flexibility consistent with the provision of data programming facilities and with the recording format capabilities. Ideally the synchronisation programming is independent of the data programming. When considerable flexibility is required in the data recording capability of the system the corresponding synchronisation arrangements, especially for good data security and high packing density, can amount to a logic unit of considerable complexity.

10.3 Encoding methods in the write operation⁴⁷

Two basic requirements apply to digital recording: to recover from the tape a signal in which the original two binary states, whatever their sequence pattern, may be reliably recognised, and to achieve the greatest possible packing density (analogous in some respects to short wavelength considerations in analogue recording). Encoding is the process of converting the digital pulses, representing the data and provided by the analogue/digital converter or a digital data source, into a suitable form of write-head current to magnetise the tape. The following encoding methods are the most common for data acquisition for which some degree of standardisation, based on the IRIG Document 106-71 standards for recording telemetered data, is emerging. They are illustrated in Figs.25, 26 and 27 and all relate to a two-state, binary mode of operation.

(i) Non-return-to-zero (NRZ) methods

These have hitherto received the widest application in flight data acquisition largely because of the relative simplicity of their implementation. In recent years, however, the desire for increased lineal packing density has concentrated attention on alternative methods. There are three variants of NRZ recording (Fig.25) derived from the rules governing the switching of the write-head current from one level to the other. These are:-

NRZ-Level (NRZ-L) or NRZ-change, in which:

'one' is represented by one level of write current;

'zero' is represented by the other level;

that is, the direction of the current is reversed for every change in the binary sequence.

NRZ-Mark (NRZ-M), in which:

'one' is represented by a change in level;

'zero' is represented by no change in level;

that is, the current is reversed every time a 'one' is to be recorded.

NRZ-Space (NRZ-S), which is the reverse of NRZ-M.

The significance of the NRZ-M and NRZ-S variants is that if a bit is misread only that bit is in error, whilst with NRZ-L if a bit is the error all succeeding bits will be in error until a change of code is encountered.

The three variants are the same in their basic input/output signal characteristics. The method uses at most one current reversal (or output pulse) per bit, and this maximum occurs for NRZ-L only when an alternating sequence of 'ones' and 'zeros' occurs, for NRZ-M only when a sequence of 'ones' occurs and for NRZ-S only when a sequence of 'zeros' occurs. There is thus no redundancy in the input or output signals. Furthermore, not every bit is identified by a pulse and certain bit patterns, for example, a sequence of all 'ones' or 'zeros' in NRZ-L, can result in no output voltage for many consecutive bit intervals. The method does not, therefore, readily lend itself to self-clocking because of the likelihood of long intervals without clock resynchronisation. As packing density increases this self-clocking limitation seriously restricts the applicability of the method and an external clock track has to be provided, with the consequent loss in areal data packing density and in immunity to inter-track time displacement.

In order to cope with code sequences which result in long periods without a change in the input or output waveforms, the method requires a frequency response down to zero, or at least to a very low frequency, together with good phase linearity. The failure of the direct recording process to meet these needs results in distortion or waviness of the base line of the reproduced signal, which must be corrected before decoding can occur. This can be minimized by the addition of odd-parity bits at regular intervals, giving enhanced-NRZ²⁴.

(ii) Phase modulation methods (or Manchester codes)

The variations in replay voltage that result from extreme differences in the pulse spacing in the NRZ method may be avoided by using phase modulation techniques which also give more positive criteria about the recorded pulse during reproduction. These techniques comprise the following three variants which are illustrated in Figs.26 and 27:-

Biphase-Level (Bi ϕ -L) or split phase, in which:

'one' is represented by a -I to +I transition at the centre of the bit period;

'zero' is represented by a +I to -I transition at the centre of the bit period.

An additional current reversal has to be inserted at the end of the bit period when there are adjacent 'ones' or 'zeros', but the additional output pulses resulting can be ignored in replay.

Biphase-Mark (Bi ϕ -M) or Frequency-doubling or Harvard code, in which:

a transition occurs at the beginning of every bit period;

'one' is represented by a second transition one-half bit period later;

'zero' is represented by no second transition.

Biphase-Space (Bi ϕ -S), which is the reverse of Bi ϕ -M.

Biphase-Level may be considered as a phase modulation process in which a square wave, with one cycle per bit, has one phase for 'ones' and the opposite phase for 'zeros'. Biphase-Mark and biphase-Space may be considered as waveforms in which a sequence of 'ones' results in twice the pulse rate as a sequence of 'zeros' or *vice versa*. In all three variants the ratio of maximum to minimum pulse duration (or of the frequency of transitions) is never greater than two. The frequency bandwidth of the fundamental component of a biphase waveform thus extends from $1/2T$ to $1/T$, where T is the bit interval, the corresponding bandwidth for NRZ being 0 to $1/2T$. Relative to NRZ biphase encoding has thus the advantage of a band-pass characteristic and the disadvantage of having higher frequency components for a given bit rate. In fact the more regular waveforms of the biphase codes are in themselves a distinct advantage, as mentioned earlier. Biphase codes also have the advantage that an output is provided for each bit, thus facilitating self-clocking, provided a 'zero' to 'one' or 'one' to 'zero' change is included to establish the phase of the clock. The bit packing density need not therefore be limited by inter-track time displacement.

The advantages of the biphase methods, particularly at high packing densities, are now generally considered to outweigh the disadvantages and the methods are widely preferred for packing densities in excess of about 4000 bits/cm. However, since operation is usually in the descending region of the gap-loss

curve (section 8.2) where the replay voltages are low, the use of higher quality heads and tape transports is required to realise fully the greater pulse packing potential.

(iii) Return-to-zero (RZ) and Return-to-bias (RB) methods

The RZ method is a discrete pulse recording in which a 'one' is recorded by a short duration positive current pulse and a 'zero' by a short duration negative current pulse, or *vice versa*. In the RB method a bias current $-I$ holds the tape at one saturation level except when the recording current switches to $+I$; 'one' is thus represented by a current pulse and 'zero' by the absence of a pulse, or *vice versa*. In RZ (for 'one' and 'zero') and in RB (for 'one') each bit records two magnetisation transition zones, giving rise to a dipulse output signal which is broader than the pulse from a single current reversal. Pulse crowding will thus occur at a lower bit density than for NRZ. RZ provides a pulse in each bit interval, thus enhancing the self-clocking capability. Both have now been superseded by NRZ or biphasic methods.

(iv) Narrow-band phase modulation methods

It has been seen that the NRZ codes have two major limitations - their 'zero' frequency content and their inability to provide an output in each bit interval - and that the phase modulation codes overcome these shortcomings. The biphasic codes discussed above, however, result in a waveform in which the maximum value of the fundamental frequency is equal to the bit frequency (the minimum value being one-half the bit frequency) whereas with NRZ the maximum value of the fundamental frequency is one-half the bit frequency. Thus the biphasic codes have the disadvantage that for the same minimum wavelength recorded on the tape, only one-half of the bit density of an NRZ code would be achieved. The narrow-band phase modulation methods are claimed to combine the advantages of both NRZ and biphasic codes. An example of these methods is the Miller code⁴⁸, shown in Fig.27. It may be defined as follows:-

'one' is represented by a transition in the middle of the bit cell;

'zero' followed by a 'zero' is represented by a transition at the end of the bit cell of the first 'zero' (or, expressed differently, 'meaningless' transitions are inserted at all bit boundaries, excluding all those extra transitions which would come closer than one bit period from any other existing transition).

In this way a signal is generated in which the maximum fundamental frequency is equal to one-half the bit frequency. The octave spread is the same as for a biphasic code, but the efficiency of tape usage is in theory the same as for the NRZ code. In practice, however, because of the lack of redundancy in narrow-band phase modulation, a tendency exists for the method to require greater response to harmonics of the pulse repetition rate, so that the theoretical reduction of twice in the required bandwidth is unlikely to be achieved.

The method provides at least one transition every two-bit period, so that it is not too difficult to recover the clock. Synchronisation of the free-running, fly-wheel clock requires the presence of a 'one-zero-one' sequence in the data to ensure that the proper clock phase is used in the decoding process. Once the clock is recovered, decoding of the signal is straightforward by detecting the presence or absence of a transition in the middle of the bit period.

10.4 Decoding methods in the read operation

In the read operation in digital recording the coded waveform recovered from the recorded tape has to be processed into a form which allows each bit to be detected and correctly assigned its 'one' or 'zero' significance. Ideally the time available for decoding a bit is a full bit interval in the case of NRZ and narrow-band phase modulation and one-half a bit interval in the case of the biphasic codes. Thus the maximum bit-to-bit time displacement, or bit jitter, which can be tolerated is $\pm 50\%$ of the bit interval and $\pm 25\%$ respectively. In practice the times for decoding are less to an extent determined by many factors such as the encoding technique, the bit density and the noise level. Before decoding, various operations, such as equalisation (as in analogue direct recording) or differentiation, amplification and limiting, may be performed on the output waveform. As discussed in section 10.2, the presence of an accurate clock source is essential for sampling the voltage at the appropriate point in the bit cell.

Two basic methods of decoding the output waveforms of both NRZ and phase modulation encoding are available - amplitude sensing and peak sensing. In the former the reproduced signal is first equalised. A threshold voltage e_t is set and the two binary states are then determined by an output voltage greater than (or equal to) e_t and by one less than e_t . In the ideal case, in which there is no pulse crowding or noise, e_t can be zero and there is no ambiguity in determining the two states of the binary code. In practice, however, a threshold voltage, different from zero, has to be set and, for reliable decoding, a limit has to be set on the allowable bit packing density, since the minimum 'one' signal cannot be allowed to be less than the maximum 'zero' signal. Amplitude sensing also results in time displacements which may be an embarrassment when self-clocking is adopted. Each time a leading edge of the output voltage pulses crosses the threshold the presence of a pulse is recognised and the pulse used for clocking. But as the output waveform varies, as a result of pulse crowding or write/read imperfections, the intersection of a leading edge with the threshold voltage level will also vary in time.

The peak sensing technique (Fig.28) involves differentiation of the replayed signal, amplification and limiting and then a low-level threshold detector. This method proves a fairly accurate means of determining the location of the pulse. However, to avoid decoding errors due to the peak sensing of noise signals, it is usually necessary to provide a base-line threshold band, thus introducing to some degree the undesirable features of amplitude sensing.

Phase modulation methods, whether with amplitude sensing or peak sensing, have inherent advantages, in the read operation, over the NRZ methods. These result from the more restricted variation of output waveforms which involve only a factor two in the maximum to minimum pulse rates. This bandpass

characteristic, as well as avoiding the low frequency base-line distortion of NRZ, also reduces variations in pulse peak timing, the pulses tending to be narrower because of the cancellation of the overlapping skirts of adjacent pulses.

11. ERROR-PRODUCING EFFECTS IN THE MAGNETIC RECORDING PROCESS

11.1 Tape speed variation - flutter

Variation in the speed of the tape relative to the head is inevitable in both the record and replay operations, especially in a severe airborne environment. Its sources, in general terms, include: eccentricities of the rotating members of the tape transport, variation in capstan and spool drive torques, surface and width irregularities of tape and belts - with consequent friction variations, and cohesion between successive tape layers. Some of these result in periodic variations and are the easier to detect and deal with in the tape transport design and manufacture; others produce random variations. The variations are usually segregated into two types determined by their frequencies - in data recording low frequency variations are usually referred to as mean speed error (roughly corresponding to wow in audio recorders) and high frequency variations are termed flutter. A transition frequency of 0.2 Hz is defined in IRIG Document 106-71.

In data acquisition flutter is most usefully expressed in peak-to-peak rather than rms values, thus providing a better basis for predicting its effect on the performance of the recording system. Normally a cumulative flutter characteristic is quoted, obtained by passing the flutter signal through a low-pass filter having a variable cut-off frequency which should extend to the maximum data frequency handled by the transport. Because of the random component, such a cumulative curve will rise with frequency, and in addition each sine wave component will introduce a step in the curve as that component comes within the pass-band of the filter.

When quoting peak-to-peak values of flutter it is usual to ignore occasional random peaks provided that the value read is exceeded less than 5% of the time. When it is known that the flutter is mostly random and can be assumed to have a Gaussian amplitude probability distribution then the rms value is one quarter of the peak-to-peak value.

It is important when quoting a flutter performance to state the conditions to which it applies. The measurement of flutter invariably involves the write and read operations. In the case of a transport intended for write and read in the laboratory, both operations are performed on it. In the case of a transport intended for write only in flight this operation is performed under airborne environmental conditions and the read operation made on the same, or on a laboratory machine of superior performance, under laboratory conditions. The measurement is preferably made on more than one track, for example, the outside and centre tracks, and near the beginning, middle and end of the tape reel.

Flutter is clearly of greater significance in analogue than in digital recording. It directly creates errors in direct recording and, especially, in frequency modulated recording. Digital recording is not so much concerned with flutter, as such, as with time displacement error which, in flutter terms, is the integral of the flutter over the time interval of interest. The remainder of this subsection is therefore concerned with flutter in analogue recording, its effect in digital recording being discussed together with time displacement error in the next subsection.

In direct recording, as will be seen later for FM recording, the data signal is frequency modulated by the flutter. There is also an error in the data amplitude, since the output signal, at frequencies below the peak response (Fig.17), is proportional to frequency. However, because of the inherent inaccuracy in the direct recording process, flutter error is seldom of much practical consequence.

The effect of flutter in frequency modulation has been analysed by Dingwall and Voss⁴⁹ and by Davies⁵⁰ for a sinusoidal flutter component in both the record and replay operations. In flight test data acquisition the record flutter is usually predominant; the common expression derived in these analyses for the discriminator output may thus be simplified by disregarding the replay flutter. This in no way affects the qualitative deductions from the analysis. Also assuming identical record and replay speeds, the expression for the discriminator output becomes:

$$e_d = k \left[\Delta\omega_c \cos \left(\omega t - \frac{a\omega}{\omega_f} \sin \omega_f t \right) + \omega_c (1 - a \cos \omega_f t) - \Delta\omega_c a \cos \omega_f t \cos \left(\omega t - \frac{a\omega}{\omega_f} \sin \omega_f t \right) \right] \quad (9)$$

where e_d = discriminator output
 k = discriminator sensitivity constant
 ω = angular frequency or pulsance ($= 2\pi \times$ frequency) of the recorded data (assumed sinusoidal)
 ω_c = angular frequency or pulsance of the unmodulated carrier (before recording)
 $\Delta\omega_c$ = peak deviation of the carrier pulsance by the data
 ω_f = angular frequency or pulsance of the flutter in the record operation (assumed sinusoidal)
 a = peak flutter during recording, expressed as a fraction of the mean tape speed.

The discriminator output thus consists of three components (the constant term $k\omega_c$ normally being backed-off):-

- (a) an output at the signal frequency, frequency modulated by the flutter; its amplitude is proportional to the signal deviation and is not in error;

(b) an output at the flutter frequency with amplitude proportional to the fractional deviation of the carrier by the flutter ($a\omega_c$); this term is independent of the signal deviation, so that it is necessary to use large deviations to keep the percentage error small;

(c) an output of amplitude proportional to the product of the signal deviation and fractional flutter; it thus represents a constant percentage error in any signal recorded. It appears as a beat between the signal and flutter frequencies.

The total amplitude error due to flutter is thus the sum of (b) and (c). Taking peak values of flutter ($\cos \omega_f t = 1$) and their worst-case combination with the instantaneous data amplitude, the peak errors (expressed as a fraction of the peak deviation $\Delta\omega_c$ of the data) at the positive and negative peaks and at the cross-over of the data are respectively (disregarding k and the negative sign):-

$$a \left(1 + \frac{1}{d} \right), \quad a \left(1 - \frac{1}{d} \right) \quad \text{and} \quad \frac{a}{d}, \quad (10)$$

where $d = \Delta\omega_c / \omega_c$.

Taking, as a not unrealistic example, a peak flutter of 1%, the maximum peak errors (or noise) for deviations of 7.5% and 40% (the standard values for full-scale deviations in frequency-division multiplexed FM and single-carrier FM) are 14.3% and 3.5% respectively.

Flutter compensation techniques are clearly of interest in data acquisition. All methods of compensation require that a knowledge of the total flutter experienced by the tape be carried through to the discriminator. This is achieved by recording a sinusoidal reference signal of constant frequency on the same track as the data (for frequency-division multiplexed FM) or on a separate track (for single-carrier FM). The discriminator output for this reference track will be

$$v_d = k_1 \omega_c (1 - \cos \omega_f t), \quad (11)$$

where k_1 is the sensitivity constant of the reference discriminator.

This may be used in three ways to provide compensation. The first, an electromechanical method, is to use this output to make the tape at the replay head reproduce exactly all the velocity disturbances occurring during recording. This is usually done by comparing the phase of the replayed reference with a local standard, and servo-controlling the replay capstan so as to maintain a fixed relationship between the local standard and the replayed reference. Both amplitude and frequency errors will thus, ideally, be eliminated. The second, known as subtractive compensation, involves subtracting the output of equation (11) from that of equation (9), and results in residual peak errors of a at the data peaks and zero at the cross-over. The third compensation method, known as multiplicative compensation, involves dividing the output of equation (9) by that of equation (11). In this way, ideally, all amplitude errors are eliminated. Functional diagrams of the last two methods of electronic compensation are given in Figs. 29 and 30.

The success of all these compensation methods in practice relies on the coherence of the flutter on the data and reference signals and, in particular, on the absence of excessive dynamic skew if separate tracks are used. Compensation of high frequency flutter is especially sensitive to dynamic skew since in this case a small displacement can result in a large phase shift. In practice, a good figure for the reduction of flutter-induced noise by subtractive compensation in the skew-sensitive case is about 5 to 10, and this is not improved significantly by multiplicative compensation. When the data and reference signals are on the same track a considerably greater improvement is possible and the use of multiplicative compensation may then be justified.

So far, only the error in the amplitude of the data has been considered and the frequency modulation and beat frequency effects of equation (9) have been disregarded. The latter generally contribute little to the amplitude noise, but their presence may well be an embarrassment if harmonic or power spectral analysis of data derived from FM recording is to be performed, as frequently is the case in flight testing. This interesting aspect of flutter error is discussed by Davies⁵⁰.

11.2 Tape motion irregularity - time displacement error

The mechanical aberrations of tape motion and other aspects of the recording operation, which result in time displacement errors, constitute a very complex subject. Briefly, time displacement error may apply to a relative time displacement in the replay output of signals recorded simultaneously on a multitrack transport (usually referred to as interchannel time displacement error, ITDE) or to the relative or absolute time displacement between adjacent pulses, on a single track, applied to the system at a constant rate (usually referred to as intra-channel time displacement error). The error has both static and dynamic components.

Static timing errors result from features, such as gap scatter, gap length, head finish and wear characteristics, which are associated with the head construction, and from variations in tape path relative to the head. They can have significant magnitudes, as may be seen from the mechanical head tolerances quoted in section 14.1. However, any unacceptable residual error after the design stage and after the application of quality control procedures may usually be virtually eliminated by a combination of mechanical and electrical adjustments (time-delay and phase-correcting networks) for a given set of circumstances.

Dynamic time displacement is very much more difficult to deal with. It is closely related to flutter and generally results from the same causes. The displacements result from oscillatory weaving of the tape in its plane and relative to the head, effects popularly referred to as tape skew. There is thus a relationship between time displacement error and flutter error. The following approximate relationship for pulses recorded on the same track has been derived by Davies⁵⁰:-

$$T' = \frac{T}{r} \left[1 \pm a \frac{\sin(\pi f T)}{\pi f T} \pm b \frac{\sin(\pi f' T/r)}{\pi f' T/r} \right] \quad (12)$$

where T' = time interval between reproduced pulses
 T = time interval between recorded pulses
 r = ratio of playback to record mean speeds
 a = peak record flutter at frequency f Hz
 b = peak replay flutter at frequency f' Hz.

In deriving this equation the phase angle between the pulses and the sinusoidal flutter was chosen for maximum error; there is a phase angle which gives zero error. Thus the error in timing between the two isolated pulses is a random function having a value between the maximum given by equation (12) and zero. For a pulse train of constant spacing and a sinusoidal flutter component whose frequency is not integrally related to the pulse frequency, there will be a sinusoidal variation of the time between pulses.

It is seen from the equation that the maximum percentage timing error never exceeds the sum of the two peak percentage flutter figures, and is this value for only part of the time. For integral values of fT , taking record flutter only, the timing error is zero and can only be expected to be appreciable when fT (or the ratio of T to the flutter period) is relatively small. Davies also derives the corresponding expression for random flutter with a Gaussian distribution and considers the effect of flutter on pulse duration modulation. The results provide a means of assessing the acceptable flutter under given conditions of serial recording and help to correct the widely held belief that, even in the present era of high packing density, unlimited flutter is permissible in a tape transport intended for digital recording.

In parallel digital recording, relative timing errors resulting from skew are usually more important than the time jitter of a single track produced from flutter. An analysis of these errors, including the effect of the time delays in the write, read and detection circuits, has been made by Ziman⁵¹, and some approximate figures of packing density capabilities are derived for typical head and transport characteristics in section 12.5.

Clocking techniques have been discussed in section 10. The suitability of an external clocking technique for parallel digital recording is a function of the relative magnitudes of the mechanical and electrical tolerances affecting pulse position compared to the size of the bit interval. As bit density is increased the tolerance on timing synchronisation between clock and data will narrow. The demands then placed on the mechanical design features of the system become extreme if external clocking is to remain feasible. With self-clocking there is no basic objection to recording in parallel on a group of tracks. However, in order to hold the bits from each track until all those corresponding to the same word or character are available, deskewing buffers may be required⁵². Self-clocking still requires a reasonably uniform tape speed during reading, since the time-slot for the subsequent bit must be generated by the electronic clocking circuit at the initiation of the present bit.

As in the case of flutter compensation, it is evident that skew compensation techniques are of interest. One possible method, if it is assumed that the relative timing error between tracks is linearly related to the distance between the tracks, is to rotate the playback head about an axis normal to the plane of the tape and passing through the centre of the line of gaps. The head motion is controlled by a signal proportional to skew error derived, by phase comparison, from reference signals carried on the two edge tracks of the tape. Such a mechanical correction for skew error has been tried⁵³ but not applied to any extent. Correction by electrically controlled delay lines has also been devised⁵⁴.

11.3 Noise, cross-talk and drop-outs

These three related effects are important factors governing the performance of a tape recorder as a data storage system. It has already been seen that tape speed variation (flutter) is a major source of noise. Other sources are the inherent noise in the electronic circuits (in particular, the replay amplifier which is usually presented with signals at microvolt or millivolt levels), power supply noise, stray fields sensed by the heads, leakage from the high frequency bias source and the recording medium itself. Flutter and medium noise are unique to magnetic recording; the other sources demand consideration generally similar to that of analogous effects in other fields. Flutter noise is of direct significance in analogue recording, both direct and modulated. In digital recording it has a less direct effect, and usually of less significance, in the time domain and for both amplitude and cross-over detection techniques. A further source of noise in FM recording arises in the demodulation process, due to jitter in the cross-overs resulting from the application of a limiting operation to the varying amplitude of the replayed carrier voltage.

Tape noise firstly depends on the basic parameters of the tape, such as dimensional irregularities in the thickness of the coating and of the base and smoothness of the coating (surface asperities), and in magnetic irregularities in particle size, their distribution in the binder, their orientation and their magnetic properties. It also depends on usage factors, in particular variation in head-to-tape contact (spacing loss) and the presence of dust particles. These usage factors demand extreme attention in an airborne environment if noise is to be maintained at an acceptable level. Two principal types of tape noise are identifiable: zero-modulation noise, which arises when reproducing an erased medium with the erase and record heads energised as they would be in normal operation, but with no input signal, and modulation noise, arising when reproducing a medium which has been recorded with a given signal. The latter is a function of the instantaneous amplitude of the signal.

In commercial systems for analogue recording, noise is usually quoted as a ratio of rms full-scale signal to rms noise (S/N ratio) for the overall record/replay system. These ratios usually apply to the specified data bandwidths, but in other respects they are very ill-defined. The extent to which flutter and environmental conditions, for example, have been taken into account is never precisely stipulated. However, the quoted S/N ratios, examples of which have been given in section 9, provide some indication of the rms noise level to be expected. Their large magnitude, which in peak-to-peak terms may be about four

times the rms value if a noise power spectral density with a normal (Gaussian) distribution is assumed, for wideband direct recording and for wideband Group II frequency modulated recording should be specially noted.

Many attempts have been made to analyse theoretically the magnetic tape as a noise generator, the latest being by Mallinson⁵⁵ who derives a relatively simple expression for the maximum S/N ratio, disregarding usage factors, and finds close agreement with measurements taken on various systems. This analysis gives an interesting insight into the noise-generating process in magnetic tape.

Cross-talk is the spurious output on replay due to coupling between adjacent channels in a multi-track system or between the read process and the write process in a write/read head system in which write and read occur simultaneously. It originates mainly in the heads and not in the tape. Write/read head cross-talk, in particular, can be a serious hazard because of the much greater recording level.

A primary source of cross-talk is coupling between individual head structures in the reproduce head stack. This is prevented to a degree by shielding and other design features, discussed later in section 14. Similar coupling in the record head can produce a field at the gap of an adjacent record head. Whilst this is usually not strong enough to influence the remanence, it can combine with any other field at the gap to produce recorded cross-talk. For example, when both tracks are recording wideband FM the result will be an effective recorded modulation at the difference frequency between the signals on the two tracks⁵⁶. Cross-talk is specially relevant when a saturation carrier is applied to one head and an ac-biased signal to an adjacent head. Cross-talk in a record/replay multiple-head is discussed by Geurst⁵⁷ and in a multitrack head by Baker⁵⁸.

Head cross-talk figures quoted by head manufacturers usually refer to

$$20 \log_{10} \frac{V_2}{V_1} \text{ dB}$$

where: for direct recording - in the record head normal bias current is applied to two adjacent tracks one of which also has the normal signal current, and in the reproduce head V_1 is the output from the signal track and V_2 the output from the adjacent track.

for frequency modulated recording - in the record head one track has the normal saturation signal current applied, and in the reproduce head V_1 is the output of the signal track and V_2 the output of an adjacent track.

Figures quoted range from -30 dB to -50 dB, depending on the type of recording and whether low band, intermediate band or wideband.

Drop-outs, although not precisely defined, are generally understood to be a loss in amplitude of the playback signal, arising in the head-tape interface, of significant magnitude and duration, the qualification 'significant' requiring an interpretation in the context of a specific application and method of recording. Drop-ins, an increase in signal level over the normal value, resulting from momentary improvement in the head-to-tape contact and from noise, may also be significant. Both result also from tape-coating imperfections (magnetic and dimensional-asperities and 'holes'), contamination (internal or external to the tape) and tape imperfections resulting from poor handling by the tape transport or the operator.

The effect of asperities (protrusions) is considered by Daniel⁵⁹ as a major cause of performance degradation giving rise to a transient head-to-tape spacing given approximately by:

$$a = a_0 \exp(-r/d)^2,$$

where a_0 is the height of the asperity above the peak roughness of the surrounding surface, r is the radial distance from the asperity measured in the plane of the head surface, and d depends on the elastic constants and tension of the tape and on the head profile, being typically about 25 μm . The effect is illustrated by considering a signal of 2 μm wavelength, recorded on a 1.27mm track, and an asperity of height 0.2 μm (0.1 λ) occurring in the centre of the track on replay. The maximum loss in reproduced output will then be 30% and it will exceed 20% for some 250 cycles of the signal.

Drop-outs are clearly of special significance in high density digital recording; hence the practice of quoting a bit drop-out rate, for example 1 in 10^5 , 1 in 10^6 , etc., in relation to bit packing density. Short duration drop-outs, in particular, have a greater significance in digital recording, since in analogue recording they can be tolerated on a statistical basis.

An extensive review of this source of error, including a discussion of tape quality, drop-out measurement techniques and the operational precautions necessary to limit their occurrence, is given by Keuren⁶⁰.

Because of the complicated nature of drop-outs and their many causes the provision by tape manufacturers of precise data on the drop-out characteristics of their products cannot be expected. The following are some typical statements from manufacturers' literature:-

(a) Sandwich instrumentation tape: one drop-out per roll of 1.27 cm by 750 m. Measured by recording and reproducing NRZ pulses at 80 per cm on 7 tracks each 0.875mm wide, a reduction to less than one half the normal reproduced signal constituting a drop-out.

(b) Wideband instrumentation tape used for longitudinal (not transverse) recording: less than 10 drop-outs per 30m tape. Measured by recording and reproducing a 600kHz signal at a tape speed of

152.4 cm/s, a reduction to less than one half of the normal reproduced signal for a period $> 40 \mu\text{s}$ constituting a drop-out.

These figures can be expected to give only a rough indication of the relative quality of various tapes. For meaningful data on drop-outs it is essential to take measurements under the actual, and defined, conditions of use. It is also good practice to clean the tape in a proprietary tape cleaner before each reproduce operation (the more sensitive operation to drop-outs). The tendency is for the tape, and hence the replayed signal, to be free of drop-outs over a considerable length and then to exhibit a drop-out of sufficient size to affect one or two adjacent tracks. The number of bits, longitudinally recorded along a track, lost in such a drop-out depends on the bit packing density and the number of words lost is primarily determined by whether the recording format is parallel or serial, as already discussed in section 10.1. Because of this tendency for lost bits to occur in bursts at widely spaced intervals, rather than at a uniform rate, there is no great significance to quoting a drop-out rate such as 1 in 10^6 .

Once a tape with a good drop-out characteristic has been found and recorded, then, provided the appropriate precautions are taken in its storage and handling and frequent cleaning is applied, it should be capable of many hundreds of reproduce operations without significant deterioration.

12. DATA PACKING DENSITY

12.1 General - tape thickness

Considerable advances have been made in this aspect of magnetic recording during the last decade, largely deriving from the great interest in video recording (analogue) and in the mass storage of data in computer systems (digital). A high packing density is equally desirable in flight test data acquisition, as a means of storing a given amount of data in the smallest possible volume of medium and in order to avoid excessively high tape speeds. Three factors are of interest - the number of cycles or bits per unit length of a single track, the number of tracks per unit width of tape, and the thickness of the tape.

The thickness of the particulate tape normally used in flight test data acquisition is largely determined by its base thickness, which, in turn, is governed by the physical factors discussed in section 15. Two base thicknesses are currently specified in the International Standards Organisation Recommendation 1859⁴⁵, 38 μm and 25 μm , and a third, 12.5 μm , is also available. The 25 μm tape is now well-established and widely used, but the thinnest tape is seldom used because of transportation and handling difficulties. The usual coating thicknesses are approximately 10 μm and 5 μm , the latter now being almost universally used. Non-particulate media, discussed in section 15, are still in a somewhat experimental stage and are therefore produced in a wide variety of thicknesses, with a tendency to smaller values than for particulate media.

Lineal and track packing densities will be considered briefly, for both analogue and digital recording, in the following subsections.

12.2 Lineal packing density - analogue recording

The interest lies in recording the highest possible frequency at a given tape speed (that is, achieving the shortest possible wavelength) and the highest possible frequency whatever the tape speed. The latter involves high frequency losses and stray fields, which are mainly head design considerations, and are discussed in section 14. In the former the short wavelength problem is dominant. The highest current standards, outside the video recording field, have been discussed in section 9.1, the maximum frequency and cycles/cm being 2 MHz and about 6600 cycles/cm respectively. Applied to frequency modulation systems, these figures result in a maximum data frequency of 0.4 MHz and a maximum lineal packing density of 1312 data cycles/cm. For direct recording a packing density up to 13000 cycles/cm and a maximum frequency of 4 MHz at 304.8 cm/s are now being claimed by some head-and-systems manufacturers, but this has not yet appeared in equipment specifications.

Before adopting these criteria in data acquisition systems other, associated, performance figures must be taken into account, in particular S/N ratio, which for direct recording under the above maximum condition is about 20 dB and for FM about 30 dB. Consideration must also be given to the conditions demanded by this extreme performance and the degree to which they may be found in the adverse environment of flight testing. These conditions involve the head, the tape, the head-to-tape interface and tape drive stability.

Head requirements may be assessed by applying the loss factors quoted in section 8.2; these include head gap length (expression (5)), head gap straightness and azimuth alignment (expression (8)). As seen in the example in section 8.2, the maximum tolerable reproduce gap length is about 1 μm . In practice a value of about 0.5 μm is normally used for the reproduce gap and 1 to 2 μm for the record gap. An azimuth error of 1 μm from edge to edge of the scanned track during replay is therefore the maximum tolerable. For a track width of 1.27 mm this becomes an angle of 0.0008 rad or about 2.5 minutes of arc. The extremely small gap lengths and dimensional tolerances to be achieved in design and maintained in use are evident. The practical implications of these will be discussed in section 14.

There is also a head-gap shunt effect. Only a fraction of the recorded flux on replay threads the head coil. Even with gaps of about 25 μm , much of the flux is lost across the facing area of the confronting pole-pieces. To minimise this effect, the depth of the pole-pieces is reduced, but at the expense of head life. With a 1 μm gap, the facing area cannot be reduced in proportion, and a signal loss of about 20 dB can result.

Tape and interface requirements relate to the surface condition of the tape and the size, disposition and properties of the magnetic material immediately beneath the surface, and the surface condition of the head. These may also be assessed by application of the loss factors of section 8.2, the relevant factors in this case being separation and thickness losses (expressions (6) and (7)).

Thickness loss means that even if a uniform write magnetisation exists on the tape, the useful short wavelength magnetisation on replay is confined to a thin surface skin. For example, 75% of the output comes from a surface layer about 0.2 times the wavelength thickness. This has important implications with respect to particle size (typically $0.6 \times 0.1 \mu\text{m}$ for the usual $\gamma\text{Fe}_2\text{O}_3$ tape) and the distribution of these particles near the surface, thus establishing one critical requirement of the tape. A second is surface roughness, which determines the head-to-tape spacing and hence the spacing loss. In the example in section 8.2 it was seen that if the spacing loss is to be maintained at less than 6 dB, the greatest permissible spacing is about $0.15 \mu\text{m}$, which is considerably less than the wavelength of visible light. In addition to general surface roughness there is a distribution of discrete protrusions, or asperities, which extend beyond the surface texture and give rise to drop-outs, as discussed in section 11.3. Also, the importance of avoiding external contamination, such as dust particles, is self-evident.

High spots on the tape, from whatever cause, are also thought to account for the phenomenon of 'bouncing' whereby the tape assumes an average spacing at high speeds (usually above 250 cm/s) where its mass and flexibility prevent detailed conformity with the head.

The above factors in short wavelength recording have so far been considered only in the replay operation. They also apply, at least qualitatively, in the record operation⁶¹, and therefore demand serious attention if successful high density analogue recording is to be achieved in a flight data acquisition system.

Brophy⁶² has investigated whether, in addition to these effects, there is a magnetic limitation to short wavelength recording. Using a metal coated disc he achieved a packing density of 15000 cycles/cm and found no evidence of a head limiting effect or of a fundamental magnetic limitation. His work predicts that with improvements in heads and tapes a density of 35000 cycles/cm can be achieved, and includes a novel head design with low high-frequency loss to enable these high densities to be achieved in the megahertz band. It is wise, however, to stop to consider the implications of this claim, particularly in relation to the mechanical precision in tapes, heads, guide systems and transports - for example, the need for surface finishes better than are normally assumed in the optical field⁶³.

12.3 Lineal packing density - digital recording

As discussed in section 8.3, high density digital playback from magnetic surfaces is limited by the inability of the read head to discriminate clearly between adjacent transitions in the magnetisation of the surface. The extent of this transition region is primarily determined by the write-head field gradient and the demagnetisation of the recording medium. The latter, in turn, is controlled by the magnetic properties and the thickness of the medium. The shape and amplitude of the read pulse are a function of the magnetisation transition, the medium thickness, the head-to-medium spacing and the characteristics of the read head. These have already been discussed in section 8.3.

Although these effects are very complex and not fully analysed, it is possible to enumerate certain factors which aid pulse resolution. The following summary of recommendations by Chao⁶⁴ is considered relevant:-

- (i) Tape with the thinnest coating should be used to reduce pulse spreading. The magnetic characteristics of the oxide should have a nearly rectangular B-H loop, with a high ratio of coercivity to remanence to minimise the effect of demagnetisation.
- (ii) Although it is often said that in many digital techniques only the trailing edge of the write gap affects the pulse resolution, it is still recommended that the write gap be kept to a minimum commensurate with satisfactory operation with a given tape and write current strength. The recorded pulse width is roughly proportional to the gap length for most practical purposes.
- (iii) For a given head-tape system and packing density, the write current should be optimised to give a maximum output from the read head. The optimum write current decreases with increasing packing density. This indicates that the effect of pulse spreading, due to finite penetration into the oxide coating, is more dominant than the dependence of output on the integrated oxide thickness, the case at low packing densities.
- (iv) The read gap should be just small enough to resolve the bit interval as further reduction of gap size would degrade the signal/noise ratio without significant improvement in the total resolution.
- (v) In both the write and read heads and in the tape the surfaces should be very smooth and head-to-tape spacing as small as possible to minimise separation loss which becomes serious for short wavelength recording.

An attempt to determine a theoretical limit to digital pulse resolution in saturation recording has been made by Mallinson⁶⁵, based on the assumption that the recorded transition on the tape is a perfect step-function, but including the demagnetisation effect when the tape leaves the write head and the subsequent redistribution of the flux and remagnetisation in the presence of the read head. A constant head-to-tape spacing of $0.5 \mu\text{m}$ is assumed, as a typical effective value for current 'in-contact' digital transports. Pulse widths and amplitudes are calculated for a wide range of coating thicknesses (0.125 to $16 \mu\text{m}$) and of the magnetic properties of the tape, but it was not found possible to generalise from the results obtained.

The above applies to the saturation recording process itself (write and read resolution). In addition, consideration must be given to encoding and decoding methods, formats and clocking arrangements, as already discussed in section 10.

Up to the present relatively modest packing densities, up to about 400 bits/cm, have been used in specific applications of flight test data acquisition. Experiments have, however, been conducted in flight

which, it is claimed, establish the feasibility of considerably higher packing densities. Values in the region of 6 k bits/cm, with an error rate of 1 in 10^6 , are quoted for the NRZ-L code with linear recording and an adjacent clock track, and for the self-clocking biphasic and Miller codes. Although these figures apply to flight test conditions, the degree of severity of the flight environment, which of course can vary widely, is uncertain. It must also be realised that these figures undoubtedly demand well-maintained equipment of first class quality. Caution must therefore be advised in applying them in the flight test system of an advanced military aircraft, for which the greatest interest might frequently lie in the data acquired during the severest environmental conditions.

For the maximum areal packing density, with an acceptable error rate, it is now widely agreed that the biphasic and narrow-band phase modulation (Miller) codes show the greatest promise. The latter is comparatively new and it has not yet been convincingly demonstrated in flight test data acquisition that its theoretical promise of twice the packing density may be fulfilled in practice without a loss in data security. NRZ coding, in the enhanced form, is also regaining its popularity.

12.4 Track packing density - analogue and digital recording

In order to use efficiently the transverse dimension of the tape, which for practical reasons is usually greater than that needed by one track, multitrack operation is adopted, recording simultaneously on all or some of the tracks or recording serially along each of many tracks with either a reciprocating or loop drive for the tape. There is thus an interest in track packing density as determined by track width and intertrack spacing. The main consideration in the former is signal/noise ratio and in the latter cross-talk.

Theoretically, the read-head output per turn of the head winding is approximately directly proportional to the track width because signal fluxes from all portions of the track are in phase. The tape noise output per turn is proportional to the square root of the track width because the noise signals from different portions of the track have random phase relationships. The S/N ratio should therefore also be proportional to the square root of the track width, thus providing a limit to the track narrowness. This has been verified experimentally by Eldridge and Baaba⁶⁶ for track widths from 2.3 mm to 0.025 mm, for both sine and pulse trains (2 kHz at a tape speed of 76.2 cm/s). They also found a S/N ratio for the narrowest track of about 20 dB, which would be tolerable for many applications, and extrapolated to a S/N ratio of unity for a track 0.025 μ m wide.

The use of very narrow tracks does not in itself create more serious cross-talk problems than occur with relatively wide tracks. Cross-talk problems do arise, however, when the track spacing is reduced, because the reproduce head will then read flux from the adjacent tracks. This effect is a function of track width, track spacing, wavelength, the head arrangement and shielding, and the method of recording. For digital recording the first three factors are represented approximately by the following expression for the output, due to an adjacent track, of a read head relative to its output when positioned on the track:-

$$\text{intertrack cross-talk loss fact} = 28 \frac{d - 0.7w}{\ell} \text{ dB}$$

where d = centre-to-centre track spacing
 w = track width
 ℓ = bit length.

Thus at 200 tracks/cm ($d = 0.05$ mm), $w = 0.025$ mm and 400 bits/cm ($\ell = 0.025$ mm) the cross-talk loss factor is about 35 dB.

Cross-talk may also arise from internal head coupling during the write and read operations. In the write operation this is generally not of great importance in digital recording because of the large fields used. When large enough, the effect is to shift the position of the recorded transition, thus adding a component of 'skew' which is related to the recorded pattern and therefore called pattern sensitivity. Most of the cross-talk in a digital system will come from the internal coupling in the read head and is controlled by shields between adjacent heads in a stack. This necessity for shielding increases the size of the head and has the undesirable effect of reducing the head efficiency.

Practical factors to be considered in connection with track spacing are the provision of suitable multitrack heads, discussed in section 14, and tape guidance. The use of narrow tracks depends strongly on the tape guidance accuracy, since the read output depends on the width of the recorded track encompassed by the read head. A novel method of recording narrow tracks is described by Frost and Singer⁶⁷. A recording head of normal tracking width is used. On completing one writing pass, the head is shifted in a direction perpendicular to the track and erases the track just recorded except for the narrow region remaining as a result of the shift. The head then moves to a new track position and repeats the process. There still remains the difficulty of reading the recorded track.

In analogue recording both the S/N ratio and the cross-talk are more critical than in digital recording and result in a more severe limitation on track width and density. Current standards for track width and spacing, and new standards in preparation by the International Standards Organisation, are quoted in section 10.1. For flight test data acquisition it is generally considered that, in the present state of head developments, the track density for maximum areal packing density is 28 tracks (14 plus 14, interleaved) on 25.4mm tape for both analogue and digital recording.

12.5 Lineal packing density - digital recording in a parallel mode

When discussing serial and parallel recording modes in sections 10 and 11 reference was made to bit packing density limitations due to inter-track time displacements in parallel recording which is not self-clocking. These limitations are illustrated by the following simple analysis using the major sources of time displacement error; a more complete analysis is given by Ziman⁵¹.

The major sources of inter-track time displacement error are:-

- (a) mechanical imperfections in record and replay heads - in particular gap scatter and mean gap azimuth error (section 14.1)
- (b) static and dynamic tape skew (section 11.2)
- (c) non-linear phase shift in the write and read electronics and in the magnetic recording process.

The extent of (c) is evidently very much determined by the electronic techniques used and the detailed design of the circuits. It is disregarded here, although in practice it can make a significant contribution when due attention is paid to it. Furthermore, for parallel recording and its modest range of bit packing densities it may be assumed that there is no contribution to time displacement from the interaction of adjacent pulses on a track (peak shift due to pulse crowding).

In parallel recording, in which the bits of a data word are written simultaneously one on each track of a multitrack head/tape combination, differential time displacement in the bits of a word will not set a limit on the word packing density provided a clock signal is generated for each of the tracks and a deskewing buffer is used in the reproduction process. The packing density will, however, be limited if the self-clocking capability is applied only to some of the data tracks or if the self-clocking does not exist and separate clock tracks are recorded, the number of which may range from one per data track to one per word. The packing density capabilities of these two clocking arrangements will be derived for a 2.54cm wide tape and multitrack head.

For a multitrack head the IRIG Document recommends a maximum gap scatter (including mean gap azimuth) of 5 μm when an azimuth adjustment is possible and 2.5 μm when no such adjustment is possible. The latter figure will be taken. A typical figure for tape skew for 2.54cm tape is $\pm 5 \mu\text{m}$, assumed to vary linearly with distance in either direction from a datum at the centre of the tape. It will be assumed that a biphase encoding is used, providing a maximum time for encoding of one half the bit interval.

Taking first the case of one clock track centrally located on the 2.54cm tape, the maximum possible scatter of the read pulses of a particular data word is

$$\pm 2.5 \pm 5 \mu\text{m} = \pm 7.5 \mu\text{m} .$$

The minimum bit cell length is thus 30 μm and the maximum allowable packing density is about 330 words/cm.

In the case of a clock track adjacent to each data track or a clock derived from alternate data tracks, and a 16-track system, the maximum possible scatter of the read pulses of a data word is

$$\pm 2.5 \pm 0.625 \mu\text{m} = \pm 3.1 \mu\text{m} \text{ (approx.)} .$$

The minimum bit cell length is thus 12.4 μm and the maximum allowable packing density is about 800 words/cm.

In both cases it is reasonable to assume about one half these derived figures of packing density in order to allow for other sources of time displacement and to provide a safety factor. It is evident from a comparison of these figures with those of serial recording that severe limits on packing density exist under some conditions of parallel recording as a result of deficiencies in multitrack heads and in tape motion.

12.6 Non-saturation recording of FM and PCM

In the earlier sections it has been assumed that normally the carrier in frequency-modulated analogue recording and the pulses in digital recording are both written on the tape at saturation level. For wideband FM and digital recording at a high packing density it has been recommended for many years that non-saturation or linear (with bias) recording be used. Early work on this method is described by Best⁶⁸ who achieved reliable recording up to a packing density of about 2500 flux transitions/cm using a conventional read head with a gap of 3.8 μm .

No full explanation appears to have been found for the improved packing density claimed to be achievable with linear recording, but two effects are said to operate. A recorded transition is shorter with non-saturation recording. Layers of medium remote from the head do not become magnetised, so that the recording medium is effectively very thin. Also the surface itself is driven on a minor hysteresis loop and is thus left at a lower state of magnetisation. Both these effects - small effective coating thickness and small remanent magnetisation - tend to produce low demagnetisation and a short transition length. Furthermore, the recorded transition is effectively closer to the head in non-saturated conditions, and this proximity allows the read head to resolve the transition more faithfully.

Whatever the full explanation, it is established in practice that when attempting to increase packing density a point is reached beyond which the gain due to the avoidance of overlapping of adjacent pulses (pulse crowding) outweighs the loss due to the smaller output of non-saturation recording. This can be demonstrated experimentally by plotting a curve of reproduced signal *versus* frequency of a recorded square wave for each of two values of record current - one fully saturating the tape and the other sufficient to produce only partial penetration of the tape coating. The reduction of pulse crowding, resulting from shorter transitions, also benefits packing density by providing a corresponding reduction in peak shift - thus assisting the decoding operation. At very high packing densities it is thus established that a write current less than the normal saturation value is beneficial. It is not however universally agreed that benefit is achieved by adopting the extreme of linear recording (with bias).

Alternatively it is suggested that better results may be obtained without bias and with a write current, still less than the saturation value, having an optimum value related to the packing density.

The advent of linear recording and the use of phase modulation methods have made possible the application of frequency domain techniques, well established in the communications field, rather than time or space domain techniques, to the analysis of high density digital recording⁶⁹. These new recording methods are in effect a carrier modulation and, by comparison with communications theory, the storage capacity of the carrier is equivalent to the communication link capacity and the storage density is analogous to the information rate of transmission.

Using the well-known Shannon-Hartley equation, and replacing cycles/s by cycles/cm, Norris⁶⁹ deduces, on the basis of unity S/N ratio per track, a theoretical maximum areal bit packing density of 2×10^8 bits/cm². Applying practical limitations to this figure - 40 tracks/cm (instead of the theoretical 4×10^4), a reasonable degree of complexity in the electronics, relatively lower tolerable error rate and departure from a Gaussian noise distribution - this theoretical figure reduces to about 2×10^5 bits/cm². A digital recording system based on this theoretical work is described, in which ferrite heads with gaps of 2 μ m (write) and 0.45 μ m (read) are used. A lineal packing density of 4×10^3 bits/cm/track is achieved with an error rate of 1 in 10^8 .

13. TAPE TRANSPORTS

13.1 General description and environmental conditions

Flight test data acquisition systems at the present time rely mainly on a tape transport in which the tape is driven across the recording heads continuously and at a constant speed. Incremental motion is seldom required since the data to be recorded is acquired at a constant rate, although further development and application of adaptive techniques, producing asynchronous data, will create a demand for airborne incremental transports. Similarly, intermittent motion transports, providing a blocked format compatible with established computer standards, is seldom employed in flight, the required computer compatibility being achieved by transcription of the data in the reproduction operation on the ground, as described in section 2.

Generally, the transport is required to be capable of making high-quality recordings at a high packing density of both analogue and digital data in the severest environment experienced in a highly manoeuvrable military aircraft. In flight test systems no clear distinction may thus be drawn between so-called analogue and digital transports. For both analogue and digital recording intimate contact of the tape with the recording head and a high degree of reliable operation are prime requirements, and the need for low tape flutter in the one case and, frequently, low dynamic skew in both tend to remove any distinction that might otherwise be made.

This section will therefore be primarily concerned with high-quality airborne transports for both analogue and digital recording, individually or simultaneously, and providing a continuous tape motion at constant speed. Other design principles, more likely to be suitable in transports for the reproduction, in the laboratory, of the recorded tape, will also be briefly discussed. As the transport is the component of the system most susceptible to the airborne environment, a brief reference to the latter is made here more detailed information being readily available in the various national airborne environmental specifications. Factors of major concern are linear vibration, linear static or quasistatic acceleration, angular acceleration, temperature and humidity. Critical combinations of these are vibration and quasistatic acceleration, and temperature and humidity. Vibration normally requires the use of vibration isolators, the choice of which may be greatly embarrassed by the presence of quasistatic acceleration. Temperature and humidity normally require the use of a heater and a dessicant. Of equal importance is the prevention of the accumulation of dust particles in the sensitive head-tape interface. In the context of a high-quality tape transport, all the factors may be extremely severe and a serious hazard to the performance and the reliability of the transport. It is thus imperative that the design, manufacture and subsequent use of the transport be viewed in this light. The following simplified summary of the aircraft environmental conditions defined in the United Kingdom specification⁷⁰ illustrates the demands placed on the tape transport, in particular, and the complete acquisition system, in general.

(i) Vibration

The test procedure comprises an initial resonance search, an endurance test and a final resonance search, equipment functional tests being made at each stage and malfunction (as defined by the equipment specification) and fatigue failure being looked for. For the resonance searches sinusoidal vibration is specified, its level being determined by the equipment location and the expected flight conditions. For example, for the extremities and central fuselage of the aircraft the following range of levels are specified:-

10 to 60 Hz:	constant acceleration, ± 3 to ± 22 m/s ²
60 to 85 Hz:	constant displacement, ± 0.02 to ± 0.15 mm
85 to 1000 Hz:	constant acceleration, ± 6 to ± 44 m/s ² .

For the endurance test a wideband random motion test is preferred, with an acceleration spectral density (g^2/Hz) determined by equipment location and flight conditions, as for the resonance searches. For the central and fuselage regions the acceleration spectral density S ranges from 0.001 to 0.05 g^2/Hz and is constant over the frequency range 10 to 1000 Hz. A Gaussian amplitude distribution is specified but the peak to rms acceleration ratio need not exceed 3 to 1. The equivalent rms levels, derived from the expression

$$[S \times (f_2 - f_1)]^{\frac{1}{2}}$$

range from about 10 to 70 m/s^2 . When the flight conditions to be expected are unknown a generally accepted level of 0.01 g^2/Hz is suggested. The duration of the endurance test at the spectral densities corresponding to the flight conditions is determined by the equipment location and the expected duration of the flight conditions, the maximum duration being 50 hours.

Generally, the above tests have to be performed in three mutually perpendicular axes in turn, corresponding to vertical, lateral and fore-and-aft vibration of the aircraft. Vibration isolators shall be used if they form an integral part of, or are specified for use with, the equipment under test.

(ii) Quasistatic linear acceleration

The worst accelerations specified for normal flight conditions are:-

along longitudinal axis: $\pm 90 \text{ m/s}^2$
 along transverse axis: $\pm 140 \text{ m/s}^2$
 along normal axis - vertical: -140 or $\pm 90 \text{ m/s}^2$.

Their durations are not specified, but clearly the high values need only be applied for a short time. In addition, in crash conditions the equipment shall not break loose when subjected to a longitudinal acceleration of 250 m/s^2 .

(iii) Temperature - pressure

The worst conditions specified are:-

ground survival: -62°C , $+85^\circ\text{C}$
 ground operation: -54°C , $+85^\circ\text{C}$
 flight operation: -54°C (up to 21 km)
 $+60^\circ\text{C}$ (up to 21 km)
 $+150^\circ\text{C}$ (up to 21 km, supersonic aircraft, external exposed location).

(iv) Tropical exposure and climatic tests

After the temperature-pressure tests the equipment is subjected to cyclically varying temperatures ranging from 35°C to 20°C while the relative humidity is maintained at 95% throughout the entire test. Each cycle lasts 24 hours and is repeated 28 times. After completion the equipment is tested for proper functioning.

Various climatic tests, including temperature cycling under various conditions of relative humidity and pressure, are also specified.

13.2 Reel-to-reel transports (continuous tape motion)

The factors of primary concern in a tape transport are the tape configuration between the supply and take-up reels, the means of providing constant tape speed across the head, and the means of providing a constant tension of adequate magnitude to ensure good head-to-tape contact under all expected environmental conditions. Typical tape-reel configurations and drives currently employed in airborne transports are sketched in Figs.31 to 36. A brief description of their design and capabilities, and of some general design features, follows.

(i) Open-loop tape path (Fig.31)

The long unsupported length of tape is pulled at constant speed by the capstan when the pressure roller, which prevents slip between the tape and the capstan, is engaged. Two guides control the wrap of the tape around the head contour. The two tensioning idlers are spring-loaded, their movement with tape tension variation being sensed to control the reel driving torque. The inertia idler filters the more rapid errors in tape speed. Even so, the main objection to this configuration is that the tape at the head is not isolated from torque disturbances in the supply reel. Also, high frequency flutter is introduced by longitudinal vibration of the long unsupported length of tape. This configuration is now seldom used in a high-quality transport.

(ii) Closed-loop tape path (Fig.32)

In this system the tape is driven past the heads around a loop, each end of which is held against a single capstan by a pinch roller. This allows much better isolation from velocity disturbances arising in the reels and tensioning idlers. The tape between the supporting points is short, resulting in a great reduction in high frequency flutter. This is still a popular configuration for airborne transports, although the dual capstan drive, discussed later, is widely recognised as having superior features.

(iii) Zero-loop tape path (Fig.33)

Here the unsupported length of tape is reduced to a minimum by feeding the tape directly around the capstan. The heads are arranged to contact the tape on the capstan, and are spring-loaded against the tape to compensate for any tolerance variations. The tape can be clamped against the rotating capstan by pinch rollers or by a vacuum applied through the capstan. This system is capable of relatively low flutter, but is not used in airborne transports because of the likely effect of severe vibration on the head-tape contact.

(iv) Belt drives (cobelt) (Fig.34)

The cobelt drive⁷¹ is an alternative method of transporting the tape past the heads with protection from fluctuations in tension at the reels. It comprises a closed, polyester belt which is stretched under high tension around a number of vapour-blasted metal rollers, one of which (the capstan) drives the belt from a motor to which it is coupled. The tape is transported through the system by the belt, by which it is also pressed in intimate contact with the heads. Rollers 1 and 2 are mounted on eccentric shafts to allow tensioning of the cobelt. They are also slightly crowned to provide the necessary tracking forces to maintain the cobelt centred within the drive assembly. Since the head-to-tape contact force is provided by the cobelt, rather than by the tape tension, a wide range of tape reel tension can be tolerated by the system without the introduction of distortion or excessive drop-out. This system is currently widely used in a number of small, special-purpose tape transports designed for use in severe environments. It compares favourably in many respects with the dual capstan method to be described later, but its dynamic skew performance, its reliability, and the ease with which tape can be loaded, are generally all inferior.

A variant of the cobelt drive is the Iso-elastic drive⁷² (Fig.35). The closed, polyester belt rides directly on the outer layers of the tape in the tape reels, and is driven by a pair of differential capstans. There are no reel drive motors. The performance of this transport is rather poor.

(v) The dual capstan drive - with servo control (Fig.36)

In the closed-loop drive of Fig.32 a conflict of requirements exists between coupling the tape tightly to the capstan, to transfer as much of the smooth capstan motion as possible to the tape, and allowing enough creep to maintain tension in the loop. The most successful solution to this problem, and now one widely used in airborne transports, is the differential capstan drive. The differential capstan is a mechanism which provides that the tape is fed into the loop slightly more slowly than it is metered out, thus providing the tension in the loop, where the heads are located. The differential capstan action may be achieved by using two capstans arranged to have different peripheral speeds or by providing two diameters on one capstan. A large tape wrap angle normally eliminates the need for pinch rollers.

Fig.36 illustrates one method of implementing this principle in an airborne transport⁷³. The two capstans are coupled by a closed belt borne on a crowned pulley integral with each. The capstans are coated with silicon rubber and ground accurately to the same diameter, whilst the diameters of the crowned pulley are made slightly different. The capstans thus turn with a predetermined differential angular velocity which provides the necessary higher tension in the tape between them. Both reels and the dual capstan are each driven by a printed-armature dc motor. The angular velocity of the capstan motor shaft is controlled by a wideband servomechanism from the output of a capstan angular position sensor. Also, the tape tension where it is measured near each reel is held constant within the bandwidth of a servomechanism which automatically adjusts the reel driving torque. Thus variations which would otherwise result when the transport is subjected to angular acceleration or low-frequency vibration are eliminated. The bandwidth of the capstan servo is about 500 Hz and of the reel servo about 50 Hz, this lower value resulting from the larger inertia of the reels. Tape flutter at frequencies within these bandwidths is greatly reduced, thus also reducing the main contributions to time displacement error. The capstan and reel servomechanisms are electrically coupled so that the capstan is prevented from accelerating or slowing down more quickly than the tape can be supplied or accepted by the reels. An optimum design for the servomechanisms employed, and its method of implementation, are described by King⁷⁴.

This drive method affords two advantages over the more conventional closed loop drive. First, pinch rollers, a source of tape skew and flutter, especially under vibration, are not used; tape traction is ensured by a rubber coating on the capstans around which there is an adequate angle of tape wrap. Second, by being driven differentially the two capstans produce a predetermined strain in the tape between them, and therefore a tension which is greater than that applied by the reel driving torques. This higher tension, necessary to maintain intimate contact of the tape with the heads, is more than twice that at the reels, where only a sufficient winding tension is needed for the tape to form a pack which is stable under vibration. As virtually no power is dissipated in creating the excess tension in this way, less heat is developed in the transport, which can therefore more easily be designed to operate in a high temperature environment. A further advantage of the method results from the fact that the tape motion is at all times under the control of the capstans. Mechanical brakes are therefore not required for slowing the tape, thus avoiding excessively high stresses in the tape which would change its physical dimensions and perhaps destroy recorded data.

A tape transport with a servo-controlled dual capstan drive is shown in Fig.37. It has a tape capacity of 210 m (10.16cm reel diameter) for 25.4mm and 12.7mm wide tape, and two binary ranges of speed, 2.38 to 9.52 cm/s and 19.05 to 72.2 cm/s, electrically switched within each range and selectable by a belt change. Its dimensions are 35 × 17 × 16 cm. Another transport of basically similar design has a tape capacity of 720 m (20.32cm reel diameter) and a binary range of speeds from 2.38 to 152.4 cm/s, electrically selected. Its dimensions are 53 × 35 × 25 cm.

(vi) The Newell drive⁷⁵

This is a novel transport design principle primarily intended for very high tape speeds and data frequencies. The two tape reels are placed in direct contact with the capstan and the tape is passed directly from the supply reel to the surface of the capstan and then to the take-up reel. There are no brakes or reel motors, the reels being applied against the capstan with a force which permits transmission of a torque at their periphery. They are mounted on carriages which move under a constant force to maintain a continuous contact with the capstan whilst the tape is passing from one reel to the other. The heads are in contact with the tape at the capstan, which has a resilient coating. This approach promises many advantages but has many basic new problems associated with the tape reels and their interface with the capstan.

(vii) Reel drives with spring motors

The electric motors normally used for the reel drives may be replaced by mechanical-spring motors. The capstan then provides all the power required to overcome the frictional losses in the system. These springs are widely used in satellite transports, where a saving in electrical power is important, but have not been applied to any great extent in aircraft flight testing. A satellite recorder using a spring motor - the negator - capable of producing constant torque at all deflections is described by Buttington and Wiig⁷⁶.

(viii) Coaxial reel configurations

Both the single capstan and the differential capstan methods of providing a closed loop may be implemented with the reel surfaces coplanar or with their axes inline (coaxial). The latter allows more efficient packaging of the various components and mechanisms and can result in a smaller transport for a given capability; it is therefore frequently used in airborne transports. An example is shown in Fig.38, in which the reels are parallel but separated by sufficient distance to accommodate, between them, all the mechanisms of the transport, thus providing a symmetrical tape-path and general lay-out. The guides to change the direction of the tape-run between the capstan and reels are mounted symmetrically at 45° to the capstan and reel axes. This configuration prevents the introduction of differential distortions across the tape width, whilst the symmetry assists in producing the correct forward and back tensions for operation of the tape in either direction - a useful facility for serial recording and for continuous record/erase operation.

Of these various configurations and drives those with the best potential performance are the dual capstan and zero-loop systems, and these, combined with coaxial reels, are likely to find the widest application in the airborne tape transports of the next decade. It is also likely that the attractive features of the dc printed armature motor will be further exploited. Before the advent of this motor two components were commonly used for capstan and reel drives - the synchronous induction motor and the conventional dc motor with servo control. The former has to be accompanied by a considerable mechanical complex of belts and/or gears to provide the range of tape speeds frequently demanded in an instrumentation tape transport. The latter suffers from electrical noise generated by commutation and by torque modulation (cogging). Its armature also has a high inertia which sets a low limit on the frequency response of the servos.

These disadvantages are almost entirely absent in the dc printed armature motor. Its armature has a very low moment of inertia and a low electrical time constant, and because of its low inductance little commutation noise is generated and little brush wear occurs. The device has a wide linear torque/current range, and torque modulation, even at very low speeds, is very small because of the relatively large number of effective commutator segments. It is thus well suited, both as a capstan and spool drive, for providing a wide range of tape speeds with servo control over a wide frequency bandwidth. Also, coupled with a means of overcoming the inertia of the reels, it provides a convenient means of producing an intermittent motion for data blocking.

13.3 Other types of transports

(i) Endless-loop transports

In flight test instrumentation a closed loop of recorded tape is frequently required for data analysis. In the laboratory a long loop can be provided by incorporating a bin below the tape drive mechanism into which the tape is folded. This is satisfactory at low speeds; at high speeds an open loop may be supported on a matrix of rollers. Long loops may be provided in flight by using the one-reel cartridge developed for satellite applications. The tape is wound on a single-flange reel, and is extracted from the centre of the pack by being pulled out between the inner layer of the pack and the reel hub. After passing over the recording mechanism it is wound-up on the outside of the pack. Any of the foregoing drive arrangements may be used with this one-reel cartridge, but unless a special design feature is introduced to guide the tape where it leaves the centre of the spool the tape is liable to distort and thereby introduce high skew and flutter. The method is normally considered to be limited to relatively small tape capacities up to a few hundred metres and to tape widths up to 12.7 mm.

Since slip must occur between adjacent layers of tape it is essential to keep interlayer friction as low as possible. The transport thus requires a tape with a lubricating coating on its back surface. A limited range of tapes, coated with graphite or molybdenum disulphide, is commercially available. Another desirable, at least, feature of the tape is a high surface conductivity to reduce the static charge build-up, which would also hinder slip between the layers. Some tapes have their surface conductivity artificially increased by the application of a surface coating or by adding a conducting material to the binder.

Intensive development of this type of transport has proceeded for satellite applications for which it is now considered to be a highly reliable device. In these applications its simplicity, small size and low power consumption are attractive and the relatively easy satellite environment is conducive to a good performance. The transport also clearly has an application to flight testing when its capacity is adequate and, especially, when a small size is a primary requirement, but it is prone to malfunction near the extremes of the specified environmental conditions for, in particular, military aircraft⁷⁷.

An inertia-compensated transport, the operating volume of which is filled with a fluid of approximately the same specific gravity as the tape, has been proposed but seems not to have been widely adopted. The fluid also tends to reduce interlayer friction, but has the undesirable tendencies to keep the tape away from the head and to cause slippage in the pinch roller/tape/capstan region. Another interesting variation, applied to a few satellites, is the use of double-coated tape to provide additional recording time, for example, in a Moebius strip tape loop. But with coating on both sides of the tape there is no separation between adjacent magnetic layers and print-through of recorded data may become severe.

An endless loop, in effect, may be provided in a reel-to-reel transport with a reciprocating tape motion. One track, or a group of tracks occupying a fraction of the tape width, is first recorded along the tape and then a second track (or group of tracks) with the tape motion reversed, and so on until all the tracks are recorded. Reversal of the tape motion, and the accompanying head-current switching, may be initiated by a mechanical contact or photoelectrically through a transparent strip near each end of the tape. The reversal time, of about 0.1 second, usually results in an insignificant loss of data. The reciprocating transport finds its greatest use in accident data recording.

(ii) Intermittent and incremental transports

The intermittent transport, in conjunction with a buffer store if loss of data is to be avoided, may be used to record a primary airborne tape in a blocked, computer-compatible format. Its special feature is the ability to drive the tape to its recording speed, or to bring it to rest from its recording speed, in the shortest possible time - usually a few milliseconds. For this to be possible the inertia of all moving parts must be kept as small as possible and the inertia of the reels is avoided by providing, by mechanical or pneumatic means, temporary storage loops of tape. Although a limited number of these transports, claimed to have airborne specifications, is now available commercially, they are seldom used in flight testing. Amongst the reasons for this are the additional complexity and cost of the store and the transport, and the inefficient use of the tape. But perhaps of greater consequence are the advantages of the continuously recorded tape. This, in the data processing operation, may be read asynchronously into a specially adapted computer or, as is more usual, transcribed into computer-compatible format, as indicated in section 2. During this transcription operation, a quick-look display, a frequent requirement in flight testing, may be produced and the primary tape edited, only selected data appearing on the computer-compatible tape. The latter may then be copied and the copies used efficiently with any general purpose computer, thus facilitating the interchange of data.

Incremental transports drive the tape in steps at irregular intervals, a bit, character or word being recorded at each step. Typical incremental rates range up to about 1000/s, each bit step occupying a tape length of about 50 μm . Their use applies to input data appearing asynchronously which, at present, is seldom the case in flight testing. They are likely, however, to be applied more widely when adaptive data acquisition techniques (section 6.3) assert their influence in flight testing.

For both transports the printed armature motor, because of its ability to respond linearly to high pulse currents, can provide a suitable drive for the tape⁷⁸. It is normally used in conjunction with a dc tachometer in a velocity servo so that the motor speed adjusts itself such that the tachometer output matches a reference voltage corresponding to the required speed. An intermittent motion is then produced by switching the reference voltage between 'go' and 'stop' levels.

(iii) Miniature video recorders

The megahertz bandwidth and large storage capabilities of the transverse and helical-scan recorders, familiar in the entertainment field, are gradually being exploited in flight testing and may in the future be used for high density PCM recording in a serial format. A limited number of airborne recorders is now available. A review of the basic techniques is given in Ref.79.

(iv) Cassette and cartridge recorders

Although cassettes and cartridges are functionally similar it is usual to apply the former term to the Philips Type C-30 cassette and the latter to any other types of cassette. Also, most cassettes carry 3.81mm wide tape whilst most cartridges use 6.35mm tape. There is no accepted standard for cartridges, but the American National Standards Institute and the European Computer Manufacturers' Association have agreed on a standard for cassettes and for their data recording method. Both have for many years been a popular device for analogue recording of speech and music. In recent years they have found wide application to digital recording (or storage) in the computer field (for example, as an alternative to the punched paper tape machine), to data logging and to the recording of speech as part of an aircraft accident data recorder. These latter machines are well designed and can be used in flight test data acquisition provided their limited environmental capabilities are not exceeded.

The cassette recorders for computer and data logging applications are made with continuous, intermittent or incremental motions and can produce tapes with a standard, blocked computer format. They normally have one or two tracks (occasionally four), cater for phase modulation or NRZ coding at a packing density of 315 bits/cm and have both write and read facilities. Many of these recorders are available commercially, covering a very wide range of capabilities such as tape speed and character rates. All use the Philips cassette with a capacity of 90 m of tape 17.5 μm thick. They cover a wide range of sizes, all attractively small. As they are intended for use in the laboratory their environmental capabilities are limited - typically an operating ambient temperature range of about 0°C to 50°C and a relative humidity up to about 80%. A typical storage capacity is 330 000 8-bit characters per track.

The cartridge recorders intended for speech recording in accident data recorders are designed for operation in civil and military aircraft environments of medium severity such as are found in pressurised cabins. One example, of size 127 x 43 x 300 mm, carries 180 m of 6.35mm wide tape. In one version, recording at a tape speed of 9.52 cm/s proceeds on one track and then, by reversal of the cartridge, on a second track. In a second version a reciprocating tape motion allows single track recording on four consecutive tracks and can accept the digital serial data stream defined in the ARINC Specification 573 for accident data recording.

Both cassette and cartridge recorders present unique design problems which arise from the need to mate correctly and reliably the tape with the record head, to maintain proper head-tape contact, and to provide accurate tape and reel drives capable of maintaining the correct tension and tape position at the head. All the design approaches previously discussed are applicable. Drive systems usually rely on a capstan turned by a dc motor which is continuously running or servo controlled. In the continuous drive tape/capstan contact is made by a solenoid-operated pinch roller. The servo control eliminates the pinch

roller and its well-known shortcomings and provides the better tape speed control at the recording head. Sometimes a reel-to-reel drive, using servo-controlled reel motors on the two hubs of the cassette, is used, with often a servo-controlled tension-adjusting system as well as a servo-controlled speed-adjusting system. These latter drives are much easier on the tape but do not maintain constant speed and tension as well as a capstan.

The standard encoding methods for cassette recorders are NRZ and phase modulation, and for the latter a maximum allowable tape speed variation of $\pm 4\%$ is specified. An alternative method, named pulse-width encoding⁸⁰, has been introduced by some manufacturers because of its insensitivity to tape speed variation. In this method the bit cell is divided into three sections. A positive-going transition always occurs at the start and end of the cell, and a negative-going transition occurs at the one-third point of the cell for a 'one' and at the two-thirds point for a 'zero', or *vice versa*. For decoding, a reversible counter is triggered by the positive-going transition at the start of the cell and counting continues until the negative reversal is reached when a downward count starts. If the counter reaches zero before the next positive-going transition, then the negative-going transition must have been in the first half of the bit cell and the state of the code is determined. The precision of the method is determined by the number of counts in the bit interval; a typical counter rate is 800 kHz.

13.4 Available transports and their characteristics

To ensure that a transport satisfies all the requirements of aircraft flight test instrumentation and has the required performance in the aircraft environment it is usually necessary that it be specially developed and tested for compliance with the aircraft specifications discussed in section 13.1. However, transports for other aerospace applications with difficult environments, and even transportable transports normally intended for laboratory and field use, may also be suitable and are thus frequently used. In this subsection the primary sources of transports for flight testing are briefly discussed.

(i) Transports specially developed for flight testing

A few of these transports are currently available. Two examples have been referred to in section 13.2(v) and one of them illustrated in Fig.37. Unique features of these special-purpose transports are a heater to allow operation at low ambient temperatures and prevent the formation of ice in a humid environment, a dehumidifier to ensure satisfactory operation under ambient conditions of high humidity at high temperatures, and vibration isolators and a rigid construction to ensure a satisfactory performance and fatigue life in the severest vibration conditions. To illustrate what is available, the following are some of the leading particulars and performance figures for the transport of Fig.37 which is fairly representative of strictly airborne transports:-

Tape width and capacity:	2.54 cm; 200 m
Tape speeds:	(a) 2.38, 4.76 and 9.52 cm/s, electrically selected. (b) 19.05, 38.1 and 76.2 cm/s, electrically selected. Selection of ranges (a) or (b) is by belt change.
Controls:	All control functions (start/stop, forward/reverse, tape speed) remotely operated by DTL or TTL logic levels or by contact closure.
Heads:	Construction, track spacing and mounting to IRIG Document 106-71; two heads mounted on a removable head plate; 7, 14 or 28 tracks; 16 or 31 tracks (PCM).
Special fittings:	Vibration isolators, heater, dehumidifier.
Size and mass:	35 × 17 × 16 cm; 9 kg
Environment:	The most severe conditions discussed in section 13.1.
Tape flutter performance:	Measured as per IRIG Document 118-71, percentage peak-to-peak 2 sigma figures; ranging from 3.0% at the lowest tape speed to 1.0% at the highest tape speed in both laboratory and environmental conditions.
Tape dynamic skew performance:	≤7.5 μm peak-to-peak between the edges of 2.54cm tape under all conditions.
Effect of angular acceleration:	50% increase in the above tape flutter figures produced by ± 50 radians/s ² at low frequencies and by ± 250 radians/s ² at 100 Hz and above.

A larger version of this transport, also referred to in section 13.2(v), contains 720 m of tape, has an additional tape speed of 152.4 cm/s and roughly similar performance figures.

(ii) Weapon and rocket-borne transports

The many transports which have been specifically designed for data acquisition in guided and unguided weapon experiments provide a second source of transports for aircraft flight testing. They generally compare favourably with aircraft transports in respect of performance under severe vibration, acceleration and ambient temperature conditions. But because a small size is generally a prime requirement they lack the versatility of aircraft transports (for example, the range of tape speeds) and usually carry less tape. An example of this class of transport is shown in Fig.39. It may be provided with or without the integral power unit and with or without armoured protection for the tape. Its leading particulars are:-

Tape width and capacity: 1.27 cm; 55 m

Tape speeds: A single speed selected from 2.38, 4.76, 9.52 and 19.05 cm/s

Capstan drive: Gear drive from 400Hz hysteresis motor.

Spool drive: Fluid coupling to capstan drive.

Size and mass: 12.7cm diameter by 10cm long; 2.4 kg
(as shown in figure)

Tape flutter performance: 3.0% peak-to-peak in laboratory conditions; 6.0% peak-to-peak under vibration having a 32cm/s constant velocity characteristic from 10 Hz to 200 Hz and a 400m/s² constant acceleration characteristic up to 2000 Hz.

(iii) Satellite-borne transports^{72,81,95}

In the development of these transports emphasis is laid on a low power consumption, extreme reliability and small size and weight. Environmental conditions are relatively mild unless sterilisation at high temperature is required. Many of the transports are capable of both recording and reproducing, and the endless loop design, described in section 13.3, is often adopted. Frequent leading particulars are 6.35mm tape in relatively short lengths (for example, 50 m) single tape speeds of low value and an ambient temperature specification of -10°C to +40°C. Examples are given in Refs.72, 81 and 95.

(iv) Portable general-purpose transports

These are frequently used for flight test data acquisition when space is available and the environment is not too difficult. In performance (in laboratory conditions) and versatility they at least equal the transports specifically developed for airborne use. The favoured design is a closed-loop, low inertia system with a dual capstan to provide isolation from spool disturbances. The capstan motor is usually a low-mass device and is operated in conjunction with a phase-locked servo system controlled by an optical tachometer. Also, a facility is frequently available for recording a reference signal which may be used to match the replay speed to the record speed. Spool motors are usually dc operated and the reel torque controlled through closed-loop servos connected to tape tension sensors for both reels. These transports are often available in integrated packages also containing interchangeable plug-in modules for all or some of the standard recording methods.

Typical leading particulars for a system taking 26.67cm or 35.56cm reels of 12.7mm or 25.4mm tape are:-

Size: Transport	65 × 50 × 30 cm
Electronic modules for 14 tracks	20 × 50 × 30 cm
Power supply	20 × 50 × 30 cm
Mass: Between 50 and 75 kg.	

The specified environmental conditions are relatively mild; for example:-

Ambient temperature (up to 10000 m): 0°C to 50°C

Vibration (with vibration isolators): ±25 m/s² up to 100 Hz for a flutter level of 1.5 times that obtained in laboratory conditions.

Angular acceleration: Conditions are not quoted by the makers, but an example is 20 radians/s² in the frequency range 10 Hz to 50 Hz for a flutter level of twice that obtained in laboratory conditions. This good performance is the result of the servo control mentioned above and would not be possible without it.

Typical good figures for flutter, as defined in the IRIG Document, are 0.3% peak-to-peak at 304.8 cm/s and 1.3% peak-to-peak at 2.38 cm/s. Typical good dynamic skew is ±3 μm across 2.54cm wide tape. Many of the transports have the facility for adjusting the gap azimuth on replay so as to overcome static skew.

(v) Cassette and cartridge recorders normally intended as computer peripheral equipment or for accident data recording

These and their typical features have been discussed in section 13.3(iv).

(vi) Transports for the reproduction of flight data

For the reproduction of data in the laboratory several commercial transports having a high performance with, in particular, exceptionally low flutter, time base error and dynamic skew, and a wide range of facilities are available. They are normally rack-mounted and are accompanied by electronic units (record and reproduce) for, at least, all the direct record and single-carrier frequency modulation categories defined in IRIG Document 106-71. The units take the form of interchangeable plug-in cards; they are rapidly being extended to include PCM modules. For very accurate data acquisition, especially when accompanied by a high data packing density (analogue or digital), the advanced features of these comprehensive laboratory-based instrumentation recorders are always desirable and sometimes essential.

14. WRITE AND READ HEADS

14.1 Ring-type laminated heads

Currently, all magnetic recording in flight test data acquisition is made with the conventional ring-type head referred to in section 8.1 and illustrated in Fig.17. Also, multitrack head stacks are invariably used to record simultaneously a number of tracks on 6.25, 12.7 or 25.4mm wide tape. For convenience of fabrication and maintenance of close tolerances, multitrack heads are made from two identical limbs, each carrying the appropriate number of half-cores and half-coils. Each limb is potted in an epoxy resin and the mating faces of the two half-sections thoroughly ground and lapped. The sections are then assembled with the appropriate front gap and an incidental back gap.

The cores may be built up from laminations or ground from a ceramic ferrite material. A material of low coercivity and high permeability, which is also hard, resistant to wear and can take a high polish, is used for the laminations. Its composition is usually 80% Ni, 4% Mo, 16% Fe, the thinnest practical lamination being about 25 μm and produced by a chemical etching method. This is adequate up to a frequency of about 1 MHz but for higher frequencies the eddy current losses in the laminations become excessive and ferrite cores must be used. The front gap is formed by the insertion of a non-magnetic spacer of mica or a thin-rolled metal such as beryllium copper. This is satisfactory for gap lengths down to about 1.25 μm ; for smaller gap lengths the spacers are formed by depositing silicon dioxide or a non-magnetic metal on the gap surfaces, or, with ferrites, by glass bonding.

Heads for analogue recording, especially with bias and in the read operation, require good inter-track shielding, which is also frequently provided in digital recording. For low and medium frequencies a magnetic shield is adequate and comprises laminations of a high-permeability alloy sandwiched between the adjacent head units and extending as far as possible beyond the outline of the head. At high frequencies copper sections are added to provide eddy-current isolation. Examples of cross-talk figures for present day multichannel heads have been given in section 11.3.

Write and read heads usually differ in their gap length, as expected from the discussion in section 8, and in their coils. Low inductance coils are preferred for the write head in order to simplify the write amplifier design and to avoid resonance effects at high frequencies, especially at bias frequencies. This can be achieved without undue increase in the write current requirements since the inductance is approximately proportional to the square of the number of turns and the magnetising force is proportional to the first power. The largest possible number of turns is preferred for the read head in order to achieve the largest possible read output voltage, provided the head resonant frequency is above the maximum signal frequency. In fact, the efficiency of the read head is an important consideration. Referring to Fig.40, flux ϕ_t generated by a magnetic tape and penetrating the head laminations at the tip will partly leak across the gap g in front of the head (leakage flux ϕ_g) and will thus fail to contribute to the read output. The remaining flux ϕ_r will be conducted through the laminations and over the very small gap g_1 in the rear of the head. The flux change $d\phi_r/dt$ induces a signal voltage in the read coil.

The ratio ϕ_r/ϕ_t , which is a measure of the performance of the read head, is given by ⁸²

$$\frac{\phi_r}{\phi_t} = \left[1 + \frac{\ell/\mu + g_1 A/A_1}{gA/A_g} \right]^{-1}$$

where g = front gap length
 g_1 = back gap length
 μ = permeability of lamination material
 A = cross-sectional area of front gap
 A_g = cross-sectional area of back gap
 A_1 = cross-sectional area of the head flux path
 ℓ = length of head flux path.

Thus for optimum efficiency in the read operation: the back gap g_1 should be small in relation to the front gap g ; the area A_g at the front gap should be small and the area A_1 at the back gap large. The magnitude of μ is not all-important, so that other desirable features, such as wear and surface finish, may be given some consideration.

It is clear from discussions in earlier sections that all heads must be carefully constructed and must have highly finished gap and face surfaces in order to operate at anywhere near maximum efficiency, especially at short wavelengths and high digital pack density. The gap must also be made so that its edges are straight and smooth, and both sides must be parallel and perpendicular to the line of tape motion.

For multichannel heads there are additional requirements the most important of which concern gap scatter and gap azimuth. It is evident from commercial specifications of mechanical tolerances in these heads that the common aim of all manufacturers is the tolerances given in the IRIG Document 106-71. In addition to defining gap (or track) formats, gap (or track) width and gap (or track) centre-line spacing this document specifies maximum values for gap scatter and gap azimuth.

Mean gap azimuth is generally defined as the angle between the best mean straight line through the centres of the gaps and a line perpendicular to the reference surface of the head in the tangent plane of the head surface. Gap scatter in the IRIG Document, Appendix F, is defined as the distance between two lines perpendicular to the head reference surface which contains components of azimuth misalignment and deviations from the average line defining the azimuth. Since both components affect data time displacement, this definition of gap scatter is the inclusive distance containing the combined errors (Fig.41).

Usually the location of a gap is defined by its centre for a read head and by its trailing edge for a write head.

The maximum recommended values given in the IRIG Document for azimuth and gap scatter defined in this way are:-

Mean gap azimuth: $\pm \frac{1}{2}$ minute of arc (approximately $\pm 2.5 \mu\text{m}$ for a 25.4mm head stack).

Gap scatter: $5 \mu\text{m}$ when the record/reproduce equipment provides azimuth adjustment; $2.5 \mu\text{m}$ for fixed head systems.

These figures apply to one head stack, whatever its design - laminated or ferrite. A complete write/read operation using separate head stacks may therefore be affected by twice these figures.

14.2 Ring-type ferrite heads

Laminations create severe problems in heads for high density and high frequency recording. To fulfil the current maximum high-frequency requirement demands laminations considerably less than $25\mu\text{m}$ thick, and these, in addition to being difficult to handle, are subject to work-hardening stresses which degrade their magnetic properties. Although the stacked pole pieces can be annealed to restore, at least partially, their magnetic properties, these properties are again degraded by the lapping operations on the head surfaces. This degrading can range to a depth of 0.25 to $1.25 \mu\text{m}$, thus making the effective gap 0.5 to $2.5 \mu\text{m}$ longer than the optically measured value and the head-to-tape spacing 0.25 to $1.25 \mu\text{m}$ greater than the expected value. Furthermore, 'smearing' of each individual lamination results in an irregular gap line.

These problems have led to the development of the ferrite head. This material, because of its high resistivity, need not be laminated, and it is not magnetically degraded by lapping. Its early use, however, revealed other problems, such as fragility and the inability to produce good surface finishes because of the large and irregular grain size of existing ferrites⁹⁶.

One method in use commercially to overcome these shortcomings is to adopt a composite construction with a ferrite core and laminated, hard-metal pole tips. Two such metals, known by their trade names, are Alfesil and Spinalloy TM. The latter has a very high Vickers hardness which permits relatively shallow gap depths of approximately $75 \mu\text{m}$ whilst still achieving over 1000 hours life at a tape speed of 304.8 cm/s . The pole pieces are also designed in such a way as to minimise the long-wavelength loss referred to in section 8.2, limiting it to about 2 dB for a frequency of 400 Hz recorded at a tape speed of 304.8 cm/s . A second method is by the use of dense or hot pressed ferrites^{83,84} (nickel-zinc or magnesium-zinc) together with a glass bonding technique which enables glass to be used as a bonding agent (which holds the pole-pieces together) and to form the head gap.

These hot pressed ferrite and hard-metal tipped heads are the only ones at the present time capable of providing the narrow gaps and small high frequency losses demanded by the maximum IRIG data packing density and frequency bandwidth (especially when with-bias recording is used). They also have greater wear resistance, of particular importance when metal tape is used.

A special requirement in flight testing may be for a head to operate the write, and sometimes the read, process at a high temperature, or, at least, to survive such a temperature. A combination of an ambient temperature of $+70^\circ\text{C}$ (section 13.1) and self-heating in the transport can easily produce a head temperature of 100°C . Laminated heads with epoxy resin bonding appear to lack the mechanical/thermal stability required to maintain their characteristics, such as gap width and position, at such a temperature especially to the precision required in the read process at high packing densities. The inherent improvement in the stability of the ferrite glass-bonded head promises a corresponding improvement in its ability to operate, with an acceptable life, at temperatures in the region of 100°C .

14.3 Miscellaneous types of heads

Although the heads already discussed currently cover all requirements of flight test data acquisition, it may be of interest to refer briefly to other types which have already found application elsewhere.

(i) Flux-responsive heads

These are read heads which require no relative motion between the head and the tape for their operation. Their output is proportional to the intensity of the remanent flux that is applied to the gap. The two main types are based on magnetic modulation and on a Hall effect generator. The modulator type operates very much like a magnetometer or magnetic amplifier, and is governed by the usual modulation criteria. Its noise level is greater than that of conventional heads. Heads based on the Hall effect are described by Camras⁸⁵. They are less stable and less sensitive than the modulator types. A limited variety of both is available commercially.

(ii) Strip heads

These are intended to provide improved high-frequency performance and higher track densities. In the write head the magnetic field is produced by a relatively large current in short sections of small diameter wire, usually without any magnetic circuit. The wire may be replaced by an evaporated, or otherwise formed, strip of, for example, silver, placed transversely and edge-on to the tape. A later development by Truman⁸⁶ includes the use of ferrite in the vicinity of the strip to increase the field produced by a given strip current. To match the low impedance of the strip to the associated circuits, a pulse transformer is used, integral with the head. Results of their use for both the write and read operations are given by Truman. A further development is reported by Valstyn and Kosy⁸⁷, who propose a single-turn write head consisting of a copper strip conductor coated with a high-permeability film containing a gap. They predict that

satisfactory writing will be possible with currents of a few hundred milliamps and with better resolution than with conventional heads. Batch fabrication by vacuum deposition or plating is contemplated.

(iii) The overlap head⁸⁸

This principle allows a small gap and a narrow track to be produced with head elements which are relatively large. A block of magnetic material is attached to a slightly narrower block of non-magnetic material and aligned next to an identical two-block element so that the non-magnetic section of each is opposite the magnetic section of the other. The mating surfaces of the two elements are lapped and fixed together with a small non-magnetic spacer between them. The wider magnetic blocks then overlap slightly to produce effective pole pieces much narrower than the magnetic blocks themselves and capable of writing and reading the required narrow-track width. The two elements are fixed to a magnetic core on which is wound a coil, and the head surface is suitably contoured. Results show that the head can write and read signals at a linear density of 8000 flux reversals per cm on tracks 72 μ m wide.

14.4 Head wear

Head wear, already briefly mentioned in section 14.2, is one of the most significant system problems in wideband instrumentation recording, particularly in airborne conditions. As bandwidths and packing densities are increased, head gaps decrease in size and tape wrap angles and tensions are increased to provide closer head-to-tape contact. These practices have an adverse effect on head life, hence the importance of the degree of abrasiveness of the tape and the hardness of the head face. Head wear can be particularly bad with metal tapes and with oxide coated tapes in conditions of high relative humidity.

The characteristics of head wear vary with the conditions. Low abrasive tapes tend to wear the head without affecting the integrity of the gap. Moderately and highly abrasive tapes tend to wear the leading edge of the head and to set up a cold-flow condition which forces material into the gap, thereby creating a short; this is known as gap smear. Head clogging occurs when the tape binder system breaks down to the point where it deposits a sticky residue on the head. This lifts the tape from the head and reduces output. Because reproduce heads have more critical gap configurations than record heads, head clogging normally occurs on the trailing edge of the reproduce gap.

True head wear (not gap smear or head clogging) is a function of the tape and head materials, ambient temperature and relative humidity, tape tension, tape speed and wrap angle. Its measurement is difficult and must be made on a standard properly adjusted transport operated in a controlled environment. A trace of the head profile is taken at the beginning of the test and after a given number of tape passes. In particularly bad cases a conventional head with soft-metal laminations can suffer a loss of 1 μ m in laminations and more in shields for as few as 100 tape passes. For the hard-metal tipped and hard pressed ferrite heads, discussed in section 14.2, a life approaching 1000 hours may be expected for average conditions of use in the laboratory. No significant data, based on experience, seem to be available for head life in high density recording in flight testing.

15. THE RECORDING MEDIUM⁸⁹

15.1 Particulate tape

In-contact recording is invariably used in flight test data acquisition and the medium is almost universally a tape consisting of a particulate coating of gamma-ferric oxide ($\gamma\text{Fe}_2\text{O}_3$) on a polyester base. The magnetic particles are dispersed in a suitable binder which also bonds the coating to the base.

The oxide particles are acicular (needle shaped) with a typical length of about 0.6 μ m and a length/width ratio of about 6. The size and shape of the particles are kept as uniform as possible in manufacture, and the size kept within the range over which $\gamma\text{Fe}_2\text{O}_3$ shows single-domain behaviour. Their Curie temperature is about 600°C. The particles are usually partially aligned during manufacture, by passing them through a strong magnetic field whilst the coating is still fluid, in order to increase the remanent intensity of the surface and thus the read output - at least at low frequencies.

The essential ingredients of the binder are plastic resins with various additives such as a silicone lubricant to improve the frictional characteristics of the coating and fungicide to prohibit fungus growth. A small percentage of conductive carbon is added to the oxide-binder mix to reduce the normally high resistivity of the particulate coating, and thus minimise the problem of static charge accumulation. The ratio of oxide to binder is about 3:2. Some tape transports, for example, endless-loop transports, demand an extremely low coefficient of friction of the tape; the back surface of tapes for these is therefore treated with a lubricant, frequently graphite. Some tapes, known as sandwich tapes, have been made with a thin plastic layer over the magnetic coating to improve durability and prevent 'oxide shedding', but these have not been widely used. Improvements in oxide coating have now eliminated the need for a protective coating. After the coating process the tape is subjected to a very thorough polishing routine and finally slit into specific widths.

The required characteristics of the tape may be considered under four headings: magnetic, electrical, dimensional and physical.

Magnetic properties: In general terms the following macroscopic properties are required: a high maximum flux density, a high ratio of residual to maximum flux density, and a coercivity which is low enough to allow relatively easy recording and erasure, but high enough to inhibit undesired demagnetisation. These properties should be stable with respect to temperature, time and mechanical flexing. The microscopic properties relate to noise and to short wavelength resolution. Good particle dispersion, or freedom from agglomerates, is essential to provide media with high S/N ratios.

Electrical properties: The main requirement is a reduction in the inherently high resistivity of the magnetic coating to prevent the accumulation of static charge, particularly at high tape speeds. Charged media become difficult to handle, attract dust, and generate noise due to discharge at the heads.

Dimensional properties: The medium should be flat and straight and its width held within close tolerances throughout the spool. The tolerances specified in the International Standards Organisation Recommendation 1859 (Ref.45) are:-

$$25.4 \begin{matrix} +0 \\ -0.1 \end{matrix} \text{ mm} , \quad 12.7 \begin{matrix} +0 \\ -0.1 \end{matrix} \text{ mm} \quad \text{and} \quad 6.25 \pm 0.05 \text{ mm} .$$

Very important are the nominal thickness, uniformity of thickness and the surface smoothness of the coating. The standard thicknesses (base and coating) specified in the above International Standard Organisation Recommendation are quoted in section 12. No coating tolerances are given, but the maximum capacity of reels of standard diameters are specified in Recommendation 1860.

Nowadays the emphasis is on thin media and, in particular, on a thin coating, since it offers many advantages in analogue recording in which long wavelength linearity must be combined with a high short-wavelength output, and in digital recording at high packing densities. These advantages have already been discussed in section 12. The development of smaller oxide particles, metal particles and deposited metal films, as discussed later, can be expected to yield still thinner media. Uniformity of medium thickness is mainly required for heavily recorded long wavelengths to avoid corresponding changes in amplitude. The surface smoothness plays an all-important part, as discussed in section 12, in the performance of in-contact, high-resolution systems. General surface roughness limits the degree of contact between the head and tape, and imperfections in the form of discrete projections (asperities) cause undesirable fluctuations in signal amplitude - noise and drop-outs. Various grades of oxide and surface smoothness are used commercially to provide the so-called narrow-band and wideband tapes.

Physical properties: For in-contact recording the main ones are flexibility, high tensile and yield strengths, durability (in particular, no oxide shedding), low friction, stability with respect to temperature, humidity and time, and non-abrasive qualities.

In the light of these required characteristics other particulate coating materials have been intensively investigated, but none has yet found general favour. Amongst the non-metallic materials currently under investigation are chromium dioxide, which has the possible disadvantage of a lower Curie temperature (120°C), and cobalt-doped iron oxide, which exhibits a rather large degree of thermal instability. Metallic particles, iron and cobalt in particular, offer considerable advantages, but they are slow in being exploited commercially. They have a much higher saturation magnetisation and are therefore capable of providing a higher read voltage for the same coating thickness, or, of greater significance, the same read voltage for a coating of one quarter the thickness. They are thus capable of a higher resolution. They also offer improved noise characteristics and their lesser abrasiveness would reduce head wear.

Other base materials have also been investigated. One of particular interest in flight testing is polyimide (Kapton)⁹⁰ which is discussed later in connection with high temperature tapes.

15.2 Homogeneous and thin film tapes

A homogeneous medium (analogous to wire in wire recording), for example, stainless steel, possesses many of the desirable physical properties enumerated above. However, its lack of flexibility results in poor conformance with the head; it creates lubrication problems and its electrical conductivity can be a design embarrassment. Magnetically, all likely materials tend to have a low coercivity and low retentivity. They also offer poor resolution and a low S/N ratio. Although continuous in physical form, these materials are still composed of spontaneously saturated magnetic domains and, in general, the size of these naturally-found domains will be large compared to the particles of the same material in particulate media. Continuous media thus tend to have a relatively high noise level. Their main advantage is their relative insensitivity to high temperatures.

A more promising form of non-particulate medium consists of a thin coating of a magnetic metal on a substrate which may be metal, plastic or glass. This has the potential advantages of high output, better resolution (because of its small thickness) and higher temperature capability. Its potential disadvantages are a high permeability (and therefore demagnetisation), greater noise, poor conformity to the heads, poor lubrication and low durability (because of the thinness of the coating).

In spite of these disadvantages thin metal films appear to provide a promising alternative medium, especially for digital recording in which high output signal levels and high resolution will result from their thinness, coercivity and remanence. There are still, however, many problems to solve before thin film tapes are generally accepted as a superior alternative to $\gamma\text{Fe}_2\text{O}_3$ particulate tape. Amongst these are the lack of uniformity of magnetic and mechanical characteristics, susceptibility to corrosion (particularly at high temperature and humidity) and poor wear characteristics, all of which apply, in varying degree, to flight test data acquisition.

15.3 High temperature tapes

Of likely concern in flight testing, when the most difficult military environmental conditions are expected, is the ability of the tape to operate satisfactorily, perhaps at a high data packing density, under high temperature conditions which may be accompanied by high relative humidity; 100°C and 95% RH are typical severe conditions. Very little data on this aspect are provided by manufacturers or reported in the literature. Most authorities agree that for iron oxide particulate magnetic coatings on a polyester base the safe limits of operations for general purposes are in the region of +60°C and 80% RH, whilst the lowest safe temperature is about -60°C. The limits for long term storage are often given within a very narrow band around 20°C and 45% RH.

Although the strength properties of polyester film decrease with rising temperature, the main factor limiting the operating temperature is tape shrinkage which can commence at about 60°C and can become 0.25% after a short exposure time of a few minutes at 100°C. The shrinkage is the result of relieving the tension built into the tape during manufacture. It badly distorts the tape and eventually the oxide

loosens and transfers from layer to layer of the tape and layer-to-layer adhesion occurs. This process may be accentuated by the effects of the high temperature on the coating binder, especially if it is thermoplastic and thus subject to distortion between 55°C and 75°C. Most modern tapes, however, use thermosetting coating binders which are free from these effects, and it is likely that some binders are of a polyurethane type which could have higher temperature possibilities. A further cause of tape deformation and the embedding of foreign bodies into the coating at high temperature is the differential expansion of the spool hub and the tape. This is more serious for large spools because of the high pressure in the region of their hubs.

The material currently favoured in place of polyester as a base for high temperature tape of the non-homogeneous type is polyimide. A particular commercial variety, Kapton, is described in Ref.90. The latest claim for a tape consisting of a particulate coating on polyimide film is -30°C to +180°C for usage and -40°C to +200°C for storage, the range of relative humidity being 20% to 80% in both cases. A tape consisting of a 0.2µm metal coating on a 23µm polyimide base has also been made and is claimed to be suitable for packing densities up to 600 flux changes per mm.

A few homogeneous tapes - mainly alloys in the stainless steel category - are commercially available and some are used for aircraft accident data recording in which survival of the tape in an aircraft fire is a prime requirement. Of concern is the wear they produce in transport components such as heads and rollers. At present they are limited to digital packing densities in the region of 50 flux changes per mm.

15.4 Tape erasure, cleaning and storage

Erasure of a recorded tape depends on the well-known fact that a magnetised ferromagnetic material can be demagnetised by subjecting it to a saturating alternating field and then gradually reducing the magnitude of the field to zero. It can be accomplished by having an erasing head on the transport or by using a separate demagnetiser or degausser in the laboratory (bulk erasure of a reel of tape). Erasing heads are not normally provided on instrumentation recorders because of the danger of accidental erasure; also, the recorded reel is generally stored permanently and not reused. They are, however, used in an endless loop or reciprocating motion recorder in which the tape acts as a memory for data which are continuously updated, and are then usually energised from a high frequency oscillator at a frequency equal to the bias frequency for direct recording. Reels of tape may be bulk erased on commercially available machines operating directly from the ac mains, the necessary gradual reduction of the field being achieved by manually moving the reel slowly away from the demagnetiser. Automatic bulk erasers are also available with the ability to demagnetise tape to 80 db below normal recording level.

The highest degree of erasure, and hence of signal-to-noise ratio in subsequent use of the tape, is to be expected for a correctly operating erase head. Direct current and permanent magnet erasure operate reasonably well, but with an inferior S/N ratio, at low data packing densities. Self-erasure gives reasonable results for recording at or near saturation, but again with reduced S/N ratio. Its effectiveness reduces as data packing density, analogue or digital, increases because of the accompanying decrease in record current to reduce pulse spreading and interference.

The question of tape cleaning arises because of the possibility of the accumulation of foreign particles on the tape during use or storage and because of the build-up of oxide wear particles during the passage of the tape over the head. The tape has reached the end of its useful life when the number of drop-outs produced by these effects cannot be tolerated (section 11.3). Whilst tape cleanliness is evidently a serious consideration in computer applications, its importance should not be overlooked in flight test recording, both in relation to the original airborne recording and to subsequent reproduce and re-record processes in the laboratory. The degree of cleanliness required in flight test tapes is certain to increase as data packing densities increase, and may have already reached the point at which it would benefit by the use of some of the existing routine techniques in the computer field.

Inexpensive machines are already available for routine tape cleaning at a rate of 1300 m per minute. More elaborate machines combine mechanical cleaning with tape certification, with errors indicated on counters and their location as the tape continues moving shown on charts. Such machines also incorporate good rewinding and retensioning facilities which may be necessary to meet proper storage requirements.

It is important to ensure the proper handling and storage of tape, since the effects of temperature, humidity, stray magnetic fields and rough handling can cause loss of data during or after recording. Tape magnetisation does not deteriorate with time unless the tape is exposed to strong dc or ac fields when some erasure or a decrease in signal-to-noise ratio may occur. Weak magnetic fields may also cause print-through. Dimensional stability is the most essential characteristic of the tape. If, for example, the base film becomes brittle, warped or wavy, the tape will be useless regardless of its coating. Polyester material is relatively unsusceptible to change provided it is stored under carefully controlled conditions of temperature and humidity. The useful life of the binder, which has to provide both adhesion of the oxide coating to the base material and cohesion of the magnetic particles to each other, is also critically dependent on the storage environment.

Typical storage environmental conditions for both polyester and polyimide base tapes have already been quoted in sections 15.1 and 15.2. In addition to satisfying these, all tapes should be sealed in dust-proof bags, replaced in their original cartons and stored on edge with proper support. For storage it is also an advantage to wind the spool at a tension an order lower than the operating tension.

16. SPECIFYING A FLIGHT TEST DATA ACQUISITION SYSTEM

After starting with an assessment of the general requirement for a flight test data acquisition system, following with a general discussion of the complete system, the paper has subsequently been concerned with some of the more important individual functions of the system - their nature and implementation. The functions selected are those most intimately involved in determining the performance of the system and its efficiency in acquiring the data. In the case of the recording aspects emphasis has intentionally been placed on the basic recording process, its capabilities and its problems, and on the techniques necessary

to overcome its shortcomings. As data is of no value unless acquired with the accuracy necessary to interpret it correctly and to apply it with the desired effect to the problems for which it was acquired, much of the discussion has been concerned with error sources - how to avoid some of them and to cope to the best advantage with the others.

The organisational or, as frequently termed, housekeeping aspects of the system have received the least attention. This is not because they are unimportant; they of course play a vital part in determining the correct and reliable operation of the system and often present many problems. The flight test engineer, for whom this paper is primarily intended, however, is more concerned with the system capability and performance than he is with its organisation; he, so to speak, looks at the system from the outside rather than from the inside. He is therefore more likely to be interested in gaining knowledge which will enable him to assess the realism of his requirement and the degree of difficulty to be expected in meeting it.

It is now necessary to return to the complete system and to consider a little further the vital part played by the user in specifying his requirements, as the successful outcome of a flight test data acquisition system depends as much on this specification of requirements as it does on the subsequent design and manufacture of the hardware. It is hardly necessary at this stage to reiterate that the data acquisition system is a complex structure comprising a large number of elements which are required to function correctly individually and to relate, one with another, so as to attain an optimum overall system capability and performance.

There is no standard system which is widely accepted and has already been applied to a range of aircraft projects; this, although perhaps regrettable, is an inevitable result of the changing and wide-ranging nature of the requirements. Attempts are, however, being made to create a standard system framework and a variety of modules - ranging through all the functions from preconditioning to recording - so that, by appropriate choice of the latter and their integration within the system framework concept, specific requirements may be efficiently met. Even when this desirable aim is achieved it will still be necessary for the flight test engineer to define precisely his specific requirements. It is suggested that this specification of requirements should be largely concerned with the following six aspects: the nature and number of the input data sources; system flexibility requirements; accuracy requirements; the nature of the required outputs and the intentions regarding subsequent data handling and analysis; the environment; physical restrictions on, for example, the size and weight of the complete system or of individual packages.

Information on data sources should include: the types of transducers and other sources; the number of each; whether analogue, digital, bilevel or hybrid (e.g. pulse duration or pulse rate); if analogue, the full-scale signal level presented to the system and whether unidirectional or bidirectional, single-ended or differential; if digital, the constitution of the data word and its pulse characteristics; if bilevel, the pulse characteristics. Of special significance, as discussed in section 3, are the source impedances (including connecting cables) and their unbalance. The expected frequency bandwidth of each input parameter, and any likely exceptional behaviour (for example, transducer resonances) outside this bandwidth, should also be specified.

As the system is likely to be applied to a range of flight test tasks, it will require a degree of flexibility operative within a maximum capability. This maximum capability must be defined in terms of the maximum number of each type of data source and the maximum overall bandwidth. The latter is normally specified separately for time-division multiplexed, frequency-division multiplexed and single-data channels, or, in user terms, quasistatic, intermediate frequency and wideband channels, the maximum number of individual sources being specified for the last two and a maximum overall bandwidth (or sampling rate) for the first. This multirole requirement may also demand flexibility in the sampling rates, within the maximum capability, so that sufficient information must be provided on this point to enable the designer to determine the necessary programme facilities. Any special requirements regarding the operation of changing programmes (for example, whether changing is required in flight, frequently or infrequently) should also be specified.

The fullest possible information on accuracy requirements is vital, and the implications of high accuracy should constantly be borne in mind. High accuracy can have significant adverse effects on the cost, size and complexity of the system and, as a result of the last, on its potential reliability, stability and ease of operation. It can also prolong development and manufacturing times. The user should therefore realistically specify, for each data source, the largest possible error consistent with the subsequent use of the data. Although this may be difficult, he should avoid playing safe by quoting an unnecessarily small error. The precise conditions applicable to the quoted figures should also be made clear; can the figures, for example, be relaxed at some environmental extremes? As a guide, it may be safely stated that an overall system error (excluding data sources) of 0.1% full-scale, however this is interpreted, will present difficult and maybe insuperable problems, even with the fullest use of the best technological practices currently available or likely to be available for many years to come.

Another aspect of concern is the precise meaning of the error figures specified. It must be remembered that the system is made up of many elements, each making its own contribution to the overall system error. It is therefore necessary to specify, or at least provide information with which the designer can decide, how the various individual errors should be combined to give an overall figure. Should they, for example, be combined algebraically to give the greatest (peak) error, or should a root-mean-square (rms) or a root-sum-of-the-squares (rss) criterion be adopted? It also becomes necessary to indicate the allowable probability of occurrence of the error. A useful treatment of this, and its statistical background, is given by Topping⁹.

Briefly, a normal (Gaussian) distribution of error is assumed, or an attempt made to create this distribution in the system test procedure (for example, by arranging a normal distribution for ambient temperature change) and to eliminate systematic error. A series of measurements, x_1 to x_n , of the outputs of the system for a constant input, over a period of time and over the environmental range, are taken and their arithmetic mean \bar{x} (or their weighted mean, taking account of their frequency of occurrence)

determined. Using the normal distribution relationship, the probability that the reading will lie within a certain range centred on \bar{x} may be determined. Approximate examples are:-

range $\bar{x} \pm 1\sigma$; probability 0.68

range $\bar{x} \pm 2\sigma$; probability 0.95

range $\bar{x} \pm 3\sigma$; probability 0.997

where σ is the standard deviation (root-mean-square deviation of the data, measured from the mean) given by

$$\sigma^2 = \frac{1}{n} \sum_{s=1}^n (x_s - \bar{x})^2 .$$

If, for example, an error of $\pm 1\%$ with 0.95 probability is specified, and is assumed to refer to the deviation from the most probable value of the measured quantity (the mean), then $\sigma \approx \bar{x}/200$ and, in order to meet the specification,

$$\left[\frac{1}{n} \sum_{s=1}^n (x_s - \bar{x})^2 \right]^{1/2} \leq \frac{\bar{x}}{200} .$$

The two prime objects of providing information on the system outputs and subsequent data handling are to define clearly the extent of the responsibility of the system designer - not always self-evident - and to ensure compatibility between the system and the data handling and analysis facilities. Such information, in conjunction with other requirements, will also assist in the selection of recording methods and formats and in a judicious interpretation of accuracy requirements.

The environment is taken to include electrical conditions arising from the aircraft installation in addition to the non-electrical conditions normally specified in environmental specifications. The latter include linear vibration (specified in terms of peak amplitude, velocity or acceleration over a frequency range of sinusoidal components or as random vibration) linear and angular quasistatic acceleration, temperature and humidity. Many national specifications provide a guide for these conditions, although torsional aspects, important in magnetic recording, are seldom included. The main electrical conditions are series-mode and common-mode noise (dc and ac). The error-producing significance of the latter has been discussed in section 3. Again, it may be difficult when initiating a system development to be specific about these environmental conditions, especially common-mode voltages which are intimately related to the installation. An attempt should, however, be made, and the temptation to play safe resisted, since, like accuracy, severe environmental conditions have far-reaching implications in system design.

The final aspect of the specification, physical restrictions, is more likely to apply in the case of dense aircraft, when the restrictions should be carefully defined and kept to a minimum.

17. A GLIMPSE INTO THE FUTURE

17.1 Signal conditioning

The future nature of flight test data acquisition systems will, of course, be largely governed by developments in flight test techniques. Two general proposals under consideration, but not yet widely applied, are the increased use of dynamic manoeuvres, rather than stabilised level flight, in the flight test programme, and the control of the programme by an on-board digital computer. The dynamic manoeuvres would be specially contrived to provide the required information about the aircraft in a shorter time and with less data acquisition and data handling. Whilst this would reduce system requirements in some respects, it would at the same time create the need for greater consideration of the dynamic performance of the transducers and of the system.

The on-board digital computer is envisaged as assisting in the execution of the test programme, either by directing the pilot through the required profiles and manoeuvres or by flying the aircraft through them *via* the autopilot. The computer could then assess the results so produced and, on the basis of this assessment, direct the aircraft to the next programme step or to some alternative test. This ultimate approach would have a far-reaching effect on the data acquisition requirements and would virtually eliminate the data recording requirements.

A more likely application of the airborne digital computer in the foreseeable future is to assist in the organisation of the data acquisition process and to perform some pre-recording analysis of the data, thereby providing a degree of data compression prior to recording. This latter function is clearly applicable on a large scale in the more formal and routine flight test procedures the outcome of which can be readily and precisely defined. There are, however, many situations in flight testing when preconceived criteria cannot be defined and where the experience of the flight test engineer and the specialist is essential for the correct interpretation of the data; in these cases on-board computation is unlikely to be helpful. The process, to be valid, also demands that the reliability of the transducers and acquisition system are such that recording the raw data would not be necessary for either system checking or for backing-up data if the primary channels malfunction; the process in effect would reduce the redundancy otherwise available in the system.

The on-board computer will evidently play an increasing part in system organisation and in the implementation of specialised acquisition techniques. It is generally accepted that its introduction into flight test data acquisition will be gradual and will relate to developments in acquisition and recording techniques. The remainder of this final section of the paper is concerned with some of these likely future developments.

When discussing system arrangements in section 2 and techniques and equipment in the subsequent sections reference has been made, where appropriate, to current research activities which have not yet resulted in practical application. The shortcomings of existing equipment have also been pointed out. In the conditioning functions of the system the main need is for improved performance, especially when required to deal with analogue data sources with low-level outputs at extreme values of ambient temperature. The extent to which this need will persist, of course, depends on developments in analogue transducers and in transducers providing outputs already in digital form. Current activity relating to an improvement in the performance of semiconductor devices, in particular field-effect devices, in conjunction with new circuit techniques, are expected to result in a gradual improvement in the performance of all the conditioning functions - amplification, multiplexing, filtering and analogue/digital conversion.

Advances in integrated circuit fabrication - large scale integration - will contribute directly to the performance of the system and will allow the use of more complex techniques in aid of performance and other desirable features. For example, they will assist the implementation of adaptive techniques and the extension of the data frequency range of pulse code modulation from the quasistatic to the intermediate frequency range. Large scale integration will also have a significant effect on the physical design of the system and may help to make practical the ultimate in remote data acquisition, discussed in section 2. All the conditioning circuits, including analogue/digital conversion, will then be located at the transducer and the considerable advantage of digital transmission to a central control unit then achieved. It could equally well enable all the electronic circuits associated with the recording process to be housed in otherwise unoccupied space in the recorder itself.

In section 6.3 the use of adaptive techniques - adaptive sampling and redundancy reduction - to achieve data compression and to reduce aliasing error have been discussed. These are already widely used in telemetry systems for space vehicles and in magnetic recording systems for operational data recording (AIDS), but have not yet found wide application in flight test data acquisition. They clearly possess potential advantages in the last application, provided they have no significant adverse effect on the accuracy of the basic system, and may be extended to adaptive control of other characteristics of the system, such as channel sensitivity (determined by the gain in the system). They certainly deserve consideration in conjunction with other approaches such as on-board computation of data, and may be found a part in improving the efficiency and accuracy of future flight test data acquisition systems.

17.2 Magnetic recording

There is currently considerable activity in the study of the magnetic recording process and its application to bulk storage problems in computer systems and to video recording in both the scientific and entertainment fields. This is naturally having significant impact on flight test data acquisition requirements, which are also benefiting from specific work on airborne tape transports, heads, the recording medium and modulation techniques. Relevant aspects of this work have already been discussed in earlier sections, so that only a brief reference to some of the points is required here.

None of the physical phenomena discussed in section 14 as a basis for a write/read head appear to offer great advantage over the simplicity and flexibility of the conventional head. The latter is now available with gap lengths of less than $0.5 \mu\text{m}$ and with exceptionally good surface finish and dimensional tolerances. Further development is therefore mainly aimed at providing a technique for producing precision assemblies of batch-fabricated heads, which should result in a considerable decrease in the current high cost of multitrack heads and should also achieve a higher track density. A further likely advance is that these integrated head assemblies will also include the head preamplifiers.

The main effort on magnetic tape is in the development of higher-quality, thinner recording surfaces, rather than in a search for improved magnetic properties for which there is a broad range within which performance is not noticeably affected. Oxide coatings in an organic binder are currently available in thicknesses less than $2.5 \mu\text{m}$ with a surface finish as good as $0.05 \mu\text{m}$. Significant improvement can only be expected in thin film tape, the most promising of which appears to be Co-Ni plating. This requires an extremely good substrate, since for equivalent linear packing densities it is necessary to go to thinner layers than are required with an oxide coating. Co-Ni tape of satisfactory quality is currently being produced with a plating thickness as low as about $0.3 \mu\text{m}$. The unique advantage of these metal films is their inherent suitability for the production of a very thin, smooth magnetic layer. The development of techniques for large-scale production are well advanced and a range of thin-film tapes, with a bit packing density capability greater than that of oxide-coated tapes, may be expected.

Tape transport developments are likely to exploit further the zero loop and dual capstan drives, coaxial reel configurations and dc printed armature motors associated with wideband servo control of tape speed and tape tension. More attention will be paid to airborne transports providing intermittent, incremental or variable speed tape motion, and more use is likely to be made of transverse and helical scan techniques (video recorders) for recording serial PCM data at a high packing density and high data rate. Write and read electronics, both analogue and digital, will benefit from gradual improvements in semiconductor device performance and from large scale integration. The latter, as for acquisition electronics, will encourage the development of more sophisticated modulation techniques in aid of increased reliability and bit packing density.

17.3 Other recording methods

The requirements for bulk storage facilities in computer systems also account for considerable current research into new methods of recording data. The methods under investigation involve many media, including magnetic tape, and many write and read devices other than the magnetic head of conventional magnetic recording. Although this work is not directly aimed at flight test data acquisition requirements, it is certainly relevant and of considerable interest. A recent review of the new methods has been made by Renwick⁹². They may be broadly subdivided into surface storage devices (as in conventional magnetic recording) and storage arrays (as in conventional ferrite core stores).

The media being considered for surface storage include photographic film, photochromic film, thermoplastic tape, metal coated film in which holes are vaporised, and magnetic tape. For photographic film both the write and read operations may be performed with a laser beam or an electron beam, bit registration being achieved by conventional activation of the emulsion. With the coherent light of the laser it is also possible to store and reconstruct information in the form of holograms, each of which typically contains 10000 bits. The most convenient form of photochromic material is that in which irradiation in the optical range brings about a colour change which persists for many months at room temperature, but can be removed by heating. The write and read operations may therefore use optical techniques.

Thermoplastic recording employs electron beam writing. The recording medium consists of a transparent plastic tape coated with a thin layer of transparent, electrically conducting material which, in turn, is covered with a layer of low melting point thermoplastic about 1µm thick. In the write operation the electron beam lays down a pattern of electric charge corresponding to the data being recorded. This results in a corresponding pattern of electrostatic stress between the surface charges and the conducting film, through the low melting point thermoplastic film. Whilst still in this condition the temperature of the film is raised until the thermoplastic flows by an amount depending on the local stress. Subsequent cooling results in the freezing-in of a pattern of undulations in the surface of the thermoplastic which corresponds with the original charge pattern. This pattern is read-out with a Schlieren optical system.

When metal coated film is the medium the holes are vaporised by the use of a laser beam and the digital pattern formed is read with the aid of an optical technique.

The new methods proposed for magnetic tape involve optical write and read techniques⁹³. The write operation depends on the fact that the coercive force of most magnetic materials falls rapidly as their temperature approaches the Curie temperature. The tape is coated with a magnetic film with a low Curie temperature and magnetised in some chosen direction. In use, it is subjected to an applied field in some other direction, so that magnetisation changes will occur where it is heated to near Curie temperature. This local heating, where required to produce a magnetic change, is produced with an intensity-modulated laser beam. Thus digits are recorded as changes in direction of magnetisation, and are read by a magneto-optical effect, such as the Faraday or Kerr effect.

In all these methods, whether the recording medium is stationary or moving, the laser or electron beam has to be scanned across the medium. This is relatively straightforward in the case of the electron beam, but scans of greater than a few hundred spot diameters for a laser beam present problems, both with electro-optical and mechanical methods. Further problems exist in providing intensity modulation of the beam, in ensuring the smallest possible spot size and spot and line spacing and in line-tracking in the read process. Intensive research continues on the media, basic write and read techniques, and their practical implementation. A small number of commercial equipments are now available for computer applications, for which claims for data packing densities vary from 10^6 to 10^8 bits/cm² of the storage plane, and for write and read speeds from 10^6 to 10^8 bits/s. Even when a viable solution emerges for ground-based applications, further problems, arising from the environment and space limitations, will arise in its application to flight test data acquisition.

Current research on array stores is concerned with the possible replacement of ferrite cores with flat magnetic films, plated wire, semiconductor integrated circuits or superconducting storage elements. Their use in flight data acquisition, attractive because of their static nature, will be determined by the ability to provide the required data capacity in a package comparable in volume with a magnetic recorder and with an acceptable degree of complexity. This, of course, must take into account the volume and complexity of the associated electronics, in addition to the basic store itself, and is thus governed at least as much by integrated circuit developments (large scale integration) as it is by advances in basic storage devices. It is evident that considerable progress is required on many fronts before a generally preferred alternative to magnetic recording emerges.

REFERENCES

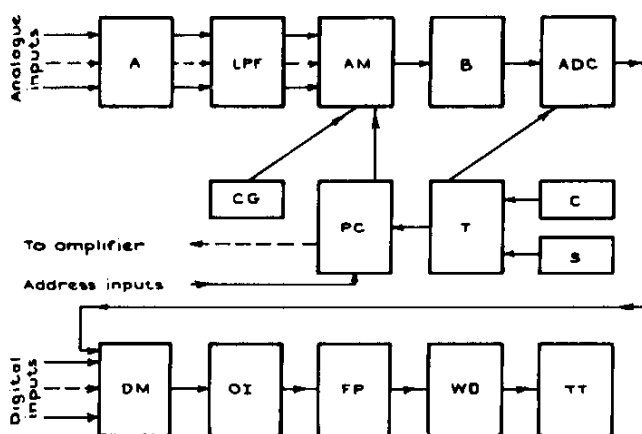
1. Betteridge, P.D. and Wreford-Bush, P.W., A digital magnetic tape instrumentation system used for flight development of the Hawker-Siddeley Harrier. Proc. 6th International Aerospace Instrumentation Symposium, Cranfield, England, pp.36.1-36.14, March 1970. Stevenage, England; Peter Peregrinus Ltd. (1970).
2. Bussenot, J.P., Flight test instrumentation of the Anglo-French aircraft Jaguar - SEPECAT. Proc. 6th International Aerospace Instrumentation Symposium, Cranfield, England, pp.21.1-21.8, March 1970. Stevenage, England; Peter Peregrinus Ltd. (1970).
3. Irwin, W.J., The 747 flight test data system. Proc. 6th International Aerospace Instrumentation Symposium, Cranfield, England, pp.17.1-17.13, March 1970. Stevenage, England; Peter Peregrinus Ltd. (1970).
4. Walters, T.T., Flight test instrumentation in Concorde aircraft. Proc. 6th International Aerospace Instrumentation Symposium, Cranfield, England, pp.32.1-32.22, March 1970. Stevenage, England; Peter Peregrinus Ltd. (1970).
5. Turfus, R.J.M., Digital data acquisition system for CF-5A testing. Proc. 6th International Aerospace Instrumentation Symposium, Cranfield, England, pp.18.1-18.6, March 1970. Stevenage, England; Peter Peregrinus Ltd. (1970).
6. Pool, A., The data collecting system for the prototype flight tests of the Fokker F-28 Fellowship. Proc. 6th International Aerospace Instrumentation Symposium, Cranfield, England, pp.33.1-33.10, March 1970. Stevenage, England; Peter Peregrinus Ltd. (1970).

7. Henney, M.L., Flight test instrumentation - the user's requirements. AGARD Conference Proc. No.32 of 30th Meeting of AGARD Flight Mechanics Panel, Montreal, Canada, pp.1-18 and 63, May 1967. London, Technical Editing and Reproduction Ltd. (1967).
8. Roberts, S.C. and Mertaugh, L., The American approach to the solution of current flight test problems. Proc. 6th International Aerospace Instrumentation Symposium, Cranfield, England, pp.16.1-16.4, March 1970. Stevenage, England; Peter Peregrinus Ltd. (1970).
9. Gugleta, S.L., Test objectives and application of flight test data by the structures engineer. AGARD Conference Proc. No.32 of 30th Meeting of AGARD Flight Mechanics Panel, Montreal, Canada, pp.43-61, May 1967. London, Technical Editing and Reproduction Ltd. (1967).
10. Rose, R., Stability and control flight testing - some of the test instrumentation requirements. AGARD Conference Proc. No.32 of 30th Meeting of AGARD Flight Mechanics Panel, Montreal, Canada, pp.65-75 and 93, May 1967. London, Technical Editing and Reproduction Ltd. (1967).
11. Bauer, W.R., Remote data acquisition terminals for Avionics and Space Systems. AGARD Conference Proc. No.67 on Data Handling Devices, Istanbul, pp.11-1 to 11-22, June 1970. NATO (1970).
12. Lowe, G.C., Low-level, high-speed multiplexing switches for data acquisition systems. RAE Technical Report 64033 (1964).
13. Smith, A.H. and Norman W.J., Balanced, direct-coupled transistor amplifiers. RAE Technical Report 65133 (1965).
14. Bright, R.L., Junction transistors used as switches. AIEE Trans. v 74, Part I, pp.111-121, March 1955.
15. Shenton, G.D., Analogue switching with field effect transistors. Second Symposium on Field Effect Transistors, West Ham College of Technology, England, May 1969.
16. Klopstein, A., The Emmanual airborne magnetic recording system. Proc. 6th International Aerospace Instrumentation Symposium, Cranfield, England, pp.34.1-34.7, March 1970. Stevenage, England; Peter Peregrinus Ltd. (1970).
17. Smith, A.H. and Macdonald, W.R., Aliasing errors in ac bridge transducer measurements. RAE Technical Note IR 33 (1963).
18. Mallinckrodt, A.J., Aliasing errors in sampled data systems. AGARD Report 316 (1961).
19. Reed, T.D. and Lloyd, J.W., A method of calculating sampling errors. RAE Technical Report 69170 (1969).
20. Nichols, M.H. and Rauch, L.L., *Radio Telemetry*. Second edition, p.405. New York, John Wiley and Sons (1956)
21. Carleton, H.D., Digital filters for routine data reduction. US Army Engineer, Waterways Experimental Station. Miscellaneous Paper N-70-1 (1970).
22. Fuykschot, P.H., A simple first-order digital filter. Proc. of the National Telemetry Conference, May 1967.
23. Fuykschot, P.H. and Bosman, D., Digital filters in flight recording. World Aerospace Systems, September 1966.
24. Hochman, D. and Weber, D.R., Adaptive telemetry - data compression. In *Aerospace Telemetry*, Vol.2, edited by H.L. Stilz, Chapter 4. New Jersey, USA, Prentice-Hall, Inc. (1966).
25. Scheinmann, R., Digital adaptive recording system. Proc. 5th International Aerospace Instrumentation Symposium, Cranfield, England, March 1968.
26. Lowe, G.C., The selection of an analogue/digital converter. Proc. 5th International Aerospace Instrumentation Symposium, Cranfield, England, March 1968.
27. Spratt, H.G.M., *Magnetic tape recording*. Second edition, p.59. London, Heywood and Co. Ltd. (1964).
28. Westmijze, W.K., Studies on magnetic recording. Phillips Research Reports, v 8, pp.161-183, 245-269, June 1953.
29. Wallace, R.L., Reproduction of magnetically recorded signals. Bell System Tech. Jour., pp.1145-1173, October 1951.
30. Begun, S.J., *Magnetic recording*. Chapter 4. New York, Rinehart and Co. (1949).
31. Camras, M., Current problems in magnetic recording. Proc. IRE, v 50, pp.751-761, May 1962.
32. Smaller, P., An experimental study of short wavelength recording performance. IEEE Trans. Magnetics, v MAG-2, p.242, September 1966.
33. Mallinson, J.C., Demagnetisation theory for longitudinal recording. IEEE Trans. Magnetics, v MAG-2, p.233, September 1966.

34. Speliotis, D.E., Magnetic recording theories: accomplishments and unresolved problems. IEEE Trans. Magnetics, v MAG-3, September 1967.
35. Kostyshyn, B., Theoretical model for a quantitative evaluation of magnetic recording systems. IEEE Trans. Magnetics, v MAG-2, pp.236-242, September 1966.
36. Morrison, J.R., An analysis of recording demagnetisation. IEEE Trans. Magnetics, v MAG-5, pp.949-954, December 1969.
37. Speliotis, D.E. and Morrison, J.R., A theoretical analysis of saturation magnetic recording. IBM Jour. Res. and Dev., v 10, No.3, pp.233-243, May 1966.
38. Mallinson, J.C. and Steele, C.W., Theory of linear superposition in digital recording. IEEE Trans. Magnetics, v MAG-5, No.3, p.186, September 1969.
39. Pear, Jr., C.B., Analogue recording methods. In *Magnetic recording in science and industry*, edited by C.B. Pear, Jr., Chapter 4. New York, Reinhold Publishing Corp. (1967).
40. Inter-Range Instrumentation Group, Range Commanders Council, Telemetry standards (revised January 1971). Document 106-71. Secretariat, Range Commanders Council, White Sands Missile Range, New Mexico.
41. Davies, G.L., *Magnetic tape instrumentation*, Chapter 3. New York, McGraw-Hill Book Co. Inc. (1961).
42. Breikss, I.P., Digital FM discriminator system. International Telemetry Conference, Los Angeles, v VI, pp.257-278 (1970).
43. Aircraft analogue equipment. Manufacturer's Brochure No.M6948. McMichael Ltd., Slough, England.
44. MacDonald, A.T., An airborne data acquisition system incorporating a recycling metal tape flight data recorder. AGARD Conference Proc. No.67 on Data Handling Devices, Istanbul, pp.10.1-10.23, June 1970. NATO (1970).
45. International Standards Organisation. ISO Central Secretariat, Geneva.
7-track 200 RPI (8 RP mm) magnetic tape for information interchange. ISO Recommendation 1861 (1971).
9-track 200 RPI (8 RP mm) magnetic tape for information interchange. ISO Recommendation 1862 (1971).
9-track 800 RPI (32 RP mm) magnetic tape for information interchange. ISO Recommendation 1863 (1971).
9-track 1600 RPI (63 RP mm) magnetic tape for information interchange. ISO Recommendation (in preparation).
Unrecorded magnetic tapes (general dimensional requirements) for instrumentation applications. ISO Recommendation 1859 (1971).
Precision reels for magnetic tape used in interchange instrumentation applications. ISO Recommendation 1860 (1971).
46. Tyler, J., Basics of pulse code modulation telemetry. Telemetry Journal, August/September 1969.
47. Hoagland, A.S., *Digital magnetic recording*. New York, John Wiley and Sons, Inc. (1963).
48. Booye, M.A., The Miller coding in direct PCM recording and reproducing. Ampex Readout, v 9, No.4, p.10.
49. Dingwall, P.F. and Voss, E.C., Errors caused by tape speed variations in analogue data recording. RAE Technical Note Instn. 159 (1957).
50. Davies, G.L., *Magnetic tape instrumentation*. Appendix 1 and Chapter 5. New York, McGraw-Hill Book Company, Inc. (1961)
51. Ziman, G.C., Maximum pulse-packing densities on magnetic tape. Electronic Engineering, v 34, No.414, pp.521-525, August 1962.
52. Gabor, A., Digital magnetic recording with high density using double transition method. IRE International Conv. Record, Part 9 (1960).
53. Comerci, F.A., A wideband recorder using frequency band division. ISA Trans., v 4, No.3, pp.240-247, July 1965.
54. Jorgensen, F. and Muskowitz, I., Reduction of tape skew in magnetic instrumentation recorders. IRE Natl. Conv. Record, Part 5 (1962).
55. Mallinson, J.C., Maximum signal-to-noise ratio of a magnetic recorder. IEEE Trans. Magnetics, v MAG-5, No.3, p.182, September 1969.
56. Pear, Jr., C.B., Analogue recording methods. In *Magnetic recording in science and industry*. Edited by C.B. Pear, Jr., p.132. New York, Reinhold Publishing Corp. (1967).
57. Geurst, J.A., Suppression of cross-talk between magnetic heads in magnetic tape memory system. Intern. Conf. on Magnetic Recording, Instn.of Elec. Eng., London, p.62, July 1964.
58. Baker, S.K., Cross-talk definitions for multichannel magnetic recording systems. IEEE Trans. Magnetics, v MAG-5, No.3, p.450, September 1969.
59. Daniel, E.D., A preliminary analysis of surface-induced tape noise. Proc. Intermag. Conf., IEEE, pp.7-1-1 to 7-1-5 (1963).

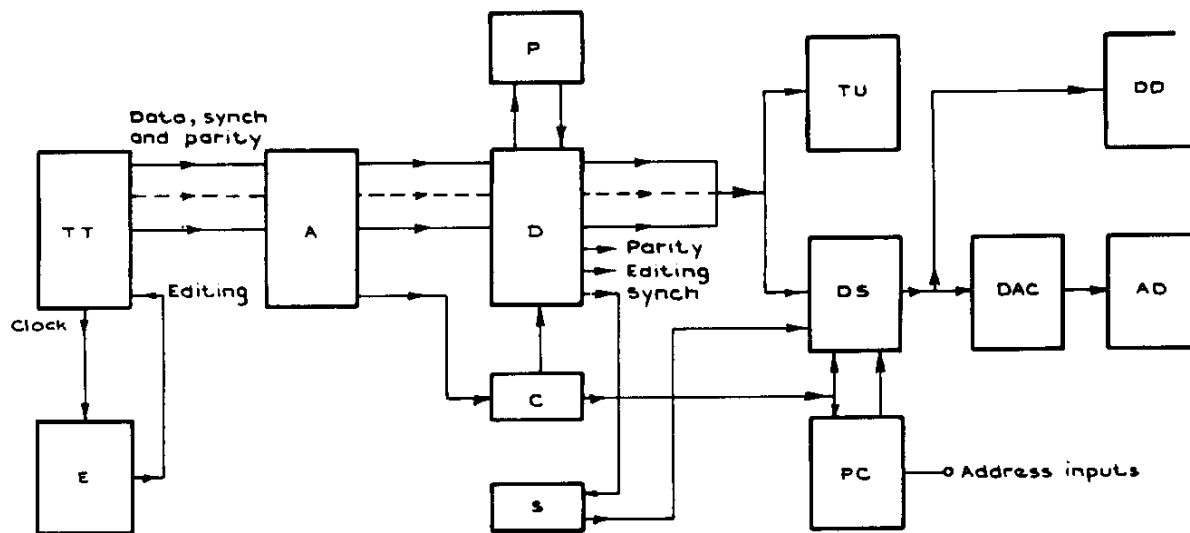
60. Van Keuren, W., An examination of drop-outs occurring in the magnetic recording and reproduction process. *Journal of the Audio Engineering Society*, v 18, No.1, p.2, February 1970.
61. Daniel, E.D., Requirements for obtaining broadband performance from magnetic tape. *Internat. Conf. on Magnetic Recording, Instn. of Elec. Eng.*, London, pp.14-18, July 1964.
62. Brophy, J.J., High-density magnetic recording. *IRE Trans. on Audio*, v AU-8, pp.58-61, March-April 1960.
63. Camras, M., Information storage density of magnetic recording and other systems. *IRE Trans. on Audio*, v AU-9, Part 5, pp.174-179, September-October 1961.
64. Chao, S.C., High density digital magnetic recording. *Internat. Conf. on Magnetic Recording, Instn. of Elect. Eng.*, London, pp.47-49, July 1964.
65. Mallinson, J.C., A theoretical limit to digital pulse resolution in saturation recording. *IEEE Trans. on Magnetics*, v MAG-5, No.2, pp.91-97, June 1969.
66. Eldridge, D.F. and Baaba, A., The effects of track width in magnetic recording. *IRE Trans. on Audio*, v AU-9, No.1, pp.10-15, January-February 1961.
67. Frost, W.T. and Singer, B.H., Increased areal density in magnetic recording. *Internat. Conf. on Magnetic Recording, Instn. of Elec. Eng.*, London, pp.44-47, July 1964.
68. Best, D.T., High density recording on tapes and drums. *UNIVAC Engineering Semiannual Symposium*, October 1963.
69. Norris, K.A., A technique for high density digital magnetic recording. A paper published by Leach Corporation, Azusa, California, USA (undated).
70. General requirements for equipment in aircraft: environmental conditions. *BSI Specification 3C.100: Part 2: Section 3*.
71. Anderson, R.S., A new approach to miniature magnetic tape transport design. *Proc. National Telemetry Conference*, 1, p.7-4 (1962).
72. Athey, S.W., *Magnetic tape recording*. Technology Survey NASA SP-5038, p.256. Washington, DC, National Aeronautics and Space Administration (1966).
73. King, J.W. and Labrum, G.R., A new magnetic tape transport for airborne data recording. *RAE Technical Report 70224* (1970).
74. King, J.W., An optimum design of a wideband servomechanism to control the shaft velocity of a printed-armature motor. *RAE Technical Report 69235* (1969).
75. Isabeau, J.G. and Vogel, C.A., The high speed tape transport. *Proc. Internat. Telemetry Conf.*, Washington, v V, pp.532-551 (1969).
76. Buttington, J.P. and Wiig, S.L., The Courier recorder-reproducers. *IRE Internat. Conv. Record*, Part 5, pp.241-249 (1961).
77. Athey, S.W., *Magnetic tape recording*. Technology Survey NASA SP-5038, pp.238-256, Washington DC, National Aeronautics and Space Administration (1966).
78. Perry, M.A., Harrison, H.M. and Barrett, L.H., The influence of new techniques and components on the design of instrumentation recorders. *Proc. 6th International Aerospace Instrumentation Symposium*, Cranfield, England, pp.2.1-2.11, March 1970.
79. Roizen, J., Magnetic video recording techniques. *Internat. Conf. on Magnetic Recording, Instn. of Elec. Eng.*, London, pp.165-170, July 1964.
80. Kaye, D.N., Pulse width and phase encoding compete to be cassette standard. *Electronics Design*, v 20, No.23, November 1972.
81. Hume, C.R., Miller, R. and Treadwell, R.J., Long-life spacecraft tape recorders. *Jour. Brit. Interplanetary Soc.*, v 24, pp.561-571 (1971).
82. Finke, G.B., Efficiency of magnetic recording heads. *IEEE Trans. Magnetics*, v MAG-5, No.1, pp.47-50, March 1969.
83. Peloschek, H.P. and Vrolijk, M.H.M., Dense ferrites and the technique of glass bonding for magnetic transducer heads. *Internat. Conf. on Magnetic Recording, Instn. of Elec. Eng.*, London, pp.82-84, July 1964.
84. Lemke, Recent advances in magnetic recording heads. *Proc. 7th International Aerospace Instrumentation Symposium*, Cranfield, England, pp.25.1-25.5, March 1972.
85. Camras, M., Some experiments with magnetic playback using Hall effect sensitive elements. *IRE Nat. Conv. Record.*, Part 7, pp.80-83 (1962).
86. Truman, N.N., A low-inductance strip-line recording head. *IEEE Trans. Magnetics*, v MAG-5, No.1, pp.43-47, March 1969.

87. Valstyn, E.P. and Kosy, D.W., The write field of a magnetic-film recording head. IEEE Trans. Magnetics, v MAG-5, No.3, pp.442-445, September 1969.
88. Frost, W.T. and Neukermans, A., Narrow-track magnetic recording head. IEEE Trans. Magnetics, v MAG-5, No.3, pp.445-448, September 1969.
89. Bate, G. and Alstad, J.K., A critical review of magnetic recording materials. IEEE Trans. Magnetics, v MAG-5, No.4, pp.821-839, December 1969.
90. Vatinelle, C., Developments in airborne crash recording. Proc. 6th International Aerospace Instrumentation Symposium, Cranfield, England, pp.4.1-4.22, March 1970.
91. Topping, J., *Errors of observation and their treatment*. London; Chapman and Hall Ltd. (1955).
92. Renwick, W., Review of digital storage technology. Physics Bulletin, v 21, pp.306-311, London, Institute of Physics, July 1970.
93. Franklin, E., The feasibility of optical writing and reading on magnetic and other recording media. UK Atomic Energy Authority Report, AERE-R5003, London, HM Stationary Office (1967).
94. Wells, J.B., High density digital magnetic tape recording using enhanced-NRZ coding. Proc. Conference on Video and Data Recording, Birmingham, England, pp.113-118, London IERE, July 1973.
95. Report of the Tape Recording Action Plan Committee. NASA SP-307, National Aeronautics and Space Administration, Washington DC, 1972.
96. Potgiesser, J.A.L. and Koorneef, J., Wear of magnetic heads. Proc. Conference on Video and Data Recording, Birmingham, England, pp.203-212, London IERE, July 1973.



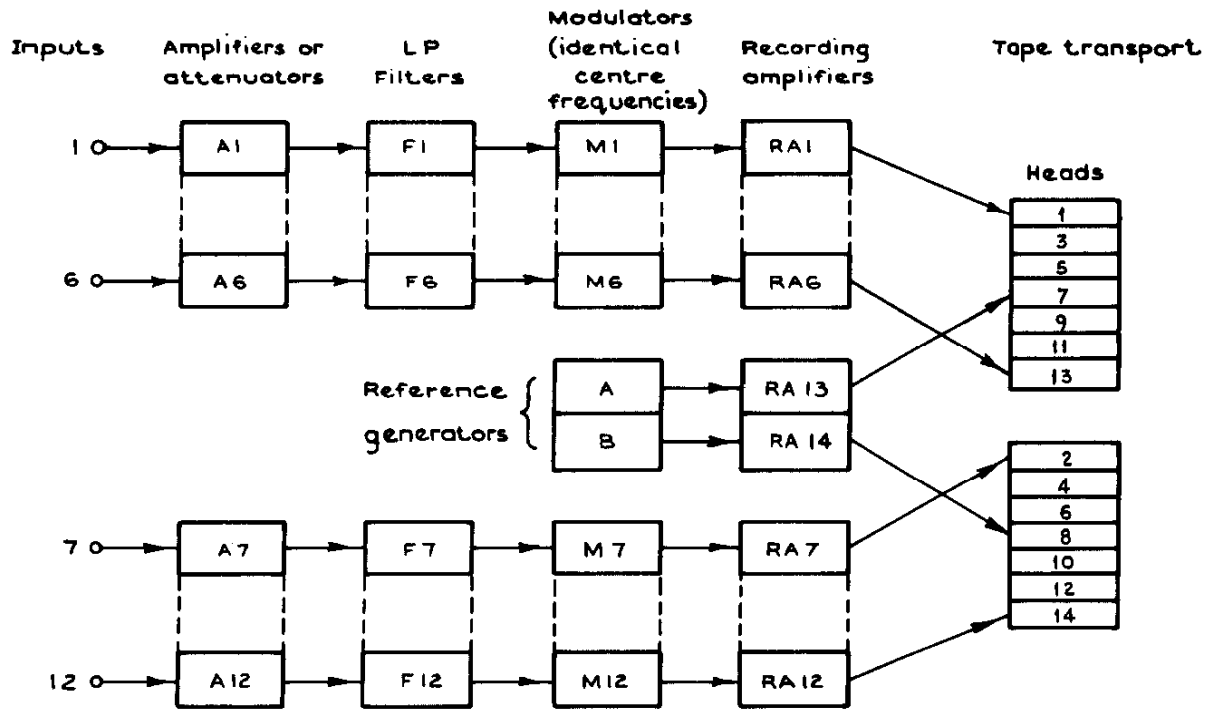
- | | | | |
|-----|------------------------------|----|-----------------------|
| A | Amplifiers / attenuators | PC | Programme control |
| LPF | Low pass filters | T | Timing |
| AM | Analogue multiplexer | C | Clock generator |
| B | Buffer amplifier | S | Synch generator |
| ADC | Analogue / digital converter | CG | Calibration generator |
| DM | Digital multiplexer | | |
| OI | output interface | | |
| FP | Format & parity generator | | |
| WD | Write coding and drive | | |
| TT | Record tape transport | | |

Fig.1 PCM (with TDM) record sub-system



- | | | | | | |
|----|---------------------------|----|-----------------------|-----|--------------------------|
| TT | Replay tape transport | P | Parity checking logic | DS | Demultiplexer and stores |
| E | Editing logic and control | C | Clock generator | TU | Transcription unit |
| A | Replay amplifier | S | synch generator | DAC | D/A converter |
| D | Decoder | PC | Programme control | AD | Analogue display |
| | | | | DD | Digital display |

Fig.2 PCM (with TDM) replay sub-system



Based on IRIG standard: 7+7 head stacks
Fig.3 Single-carrier FM record sub-system

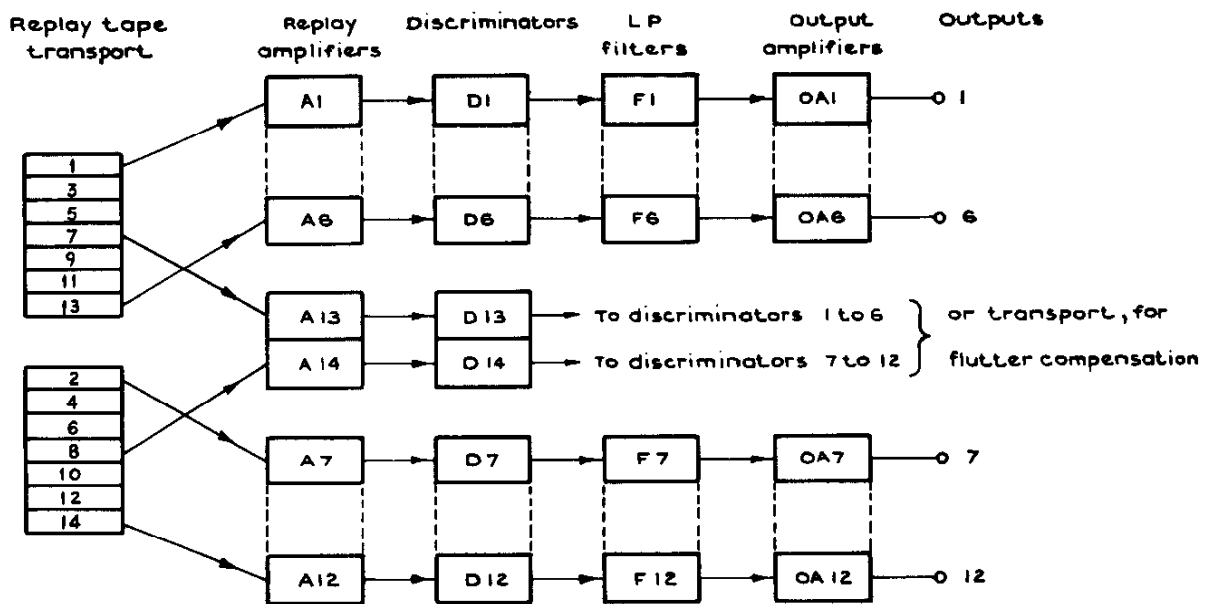
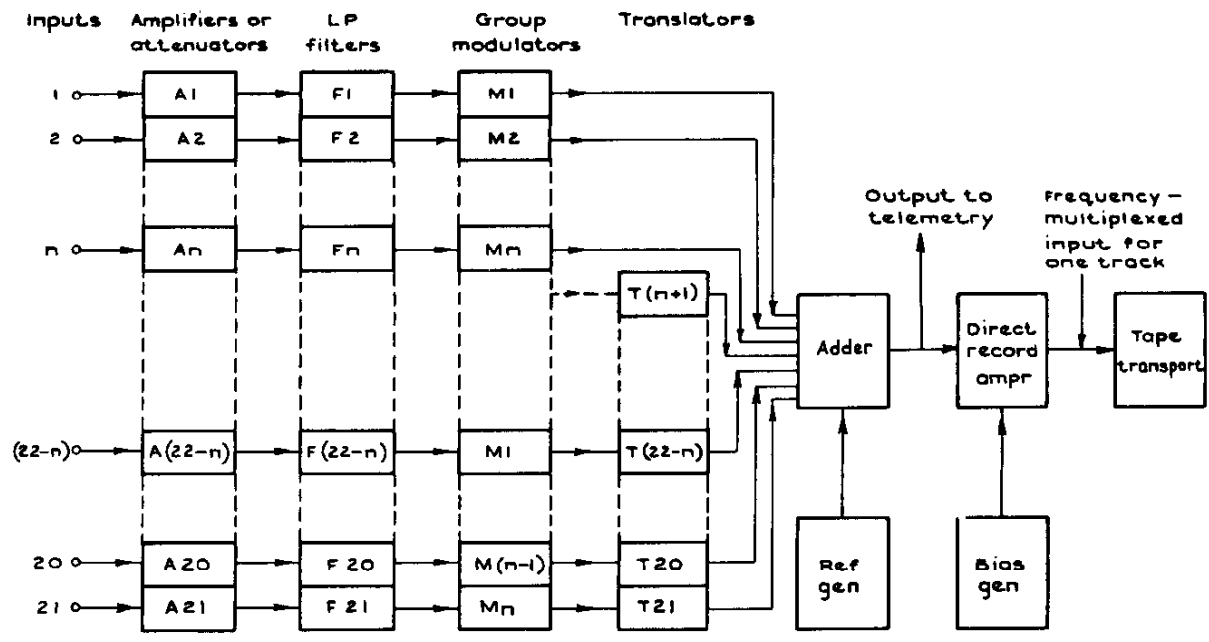


Fig.4 Single-carrier FM replay sub-system



Based on IRIG standard : 21 subcarriers

Fig.5 Frequency-division multiplexed FM record sub-system

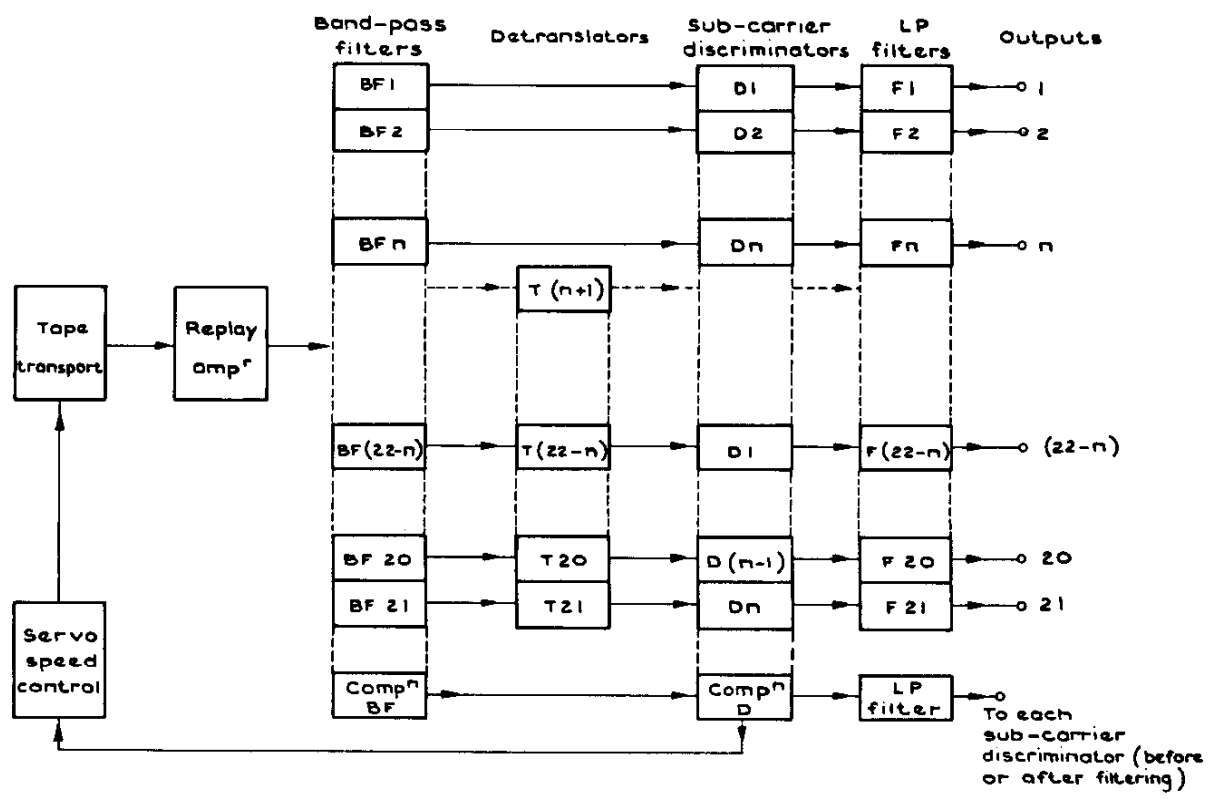


Fig.6 Frequency-division multiplexed FM replay sub-system

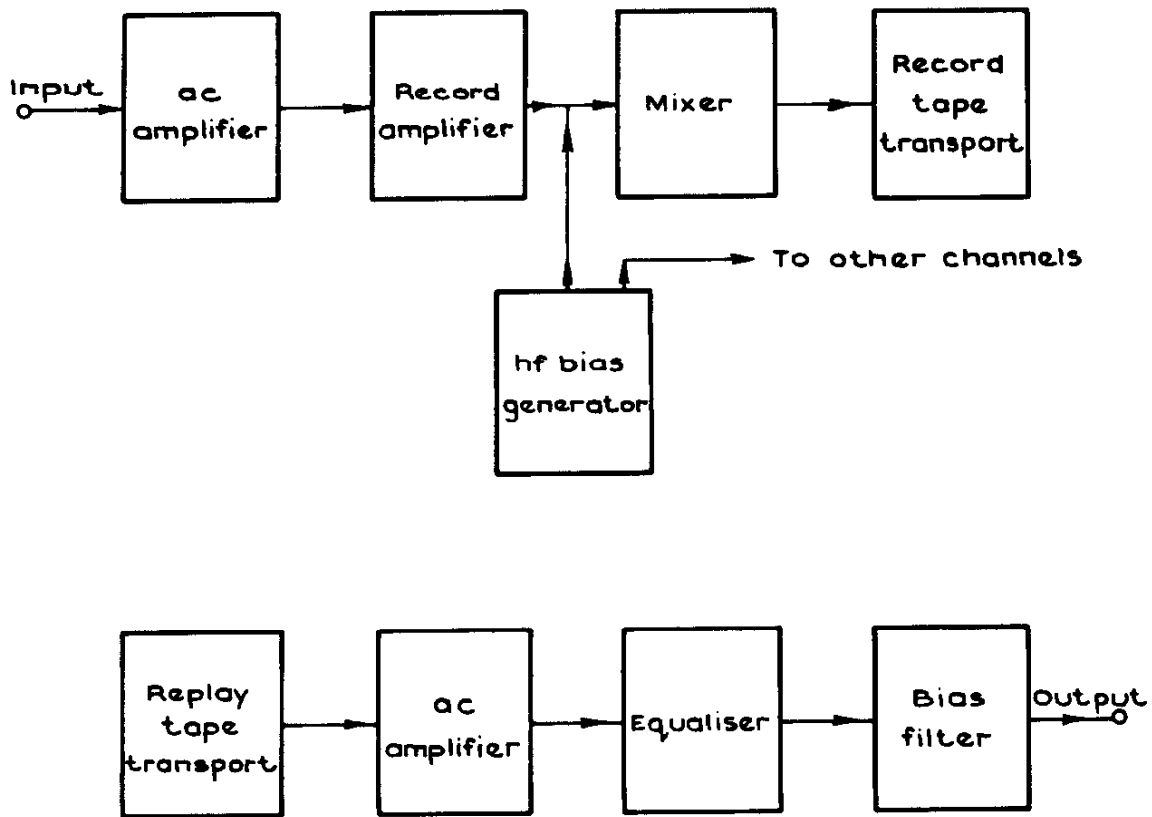


Fig.7 Direct record and replay sub-systems

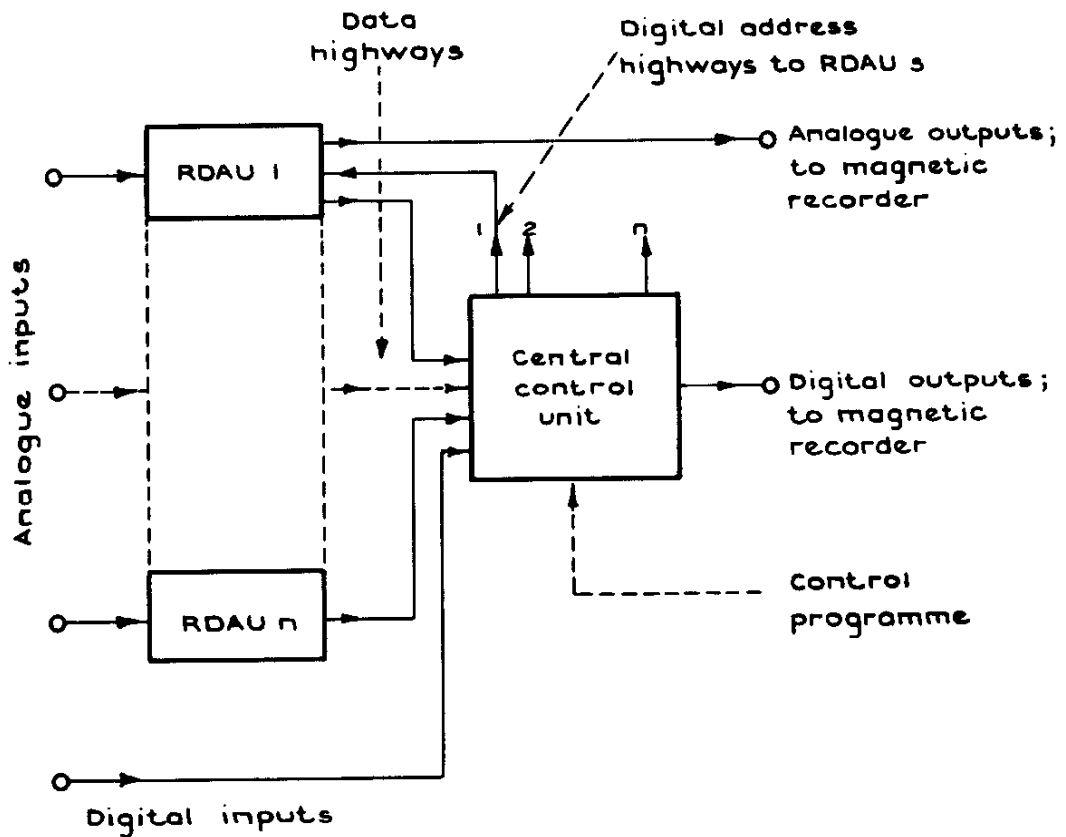


Fig.8 PCM sub-system with remote acquisition and central control

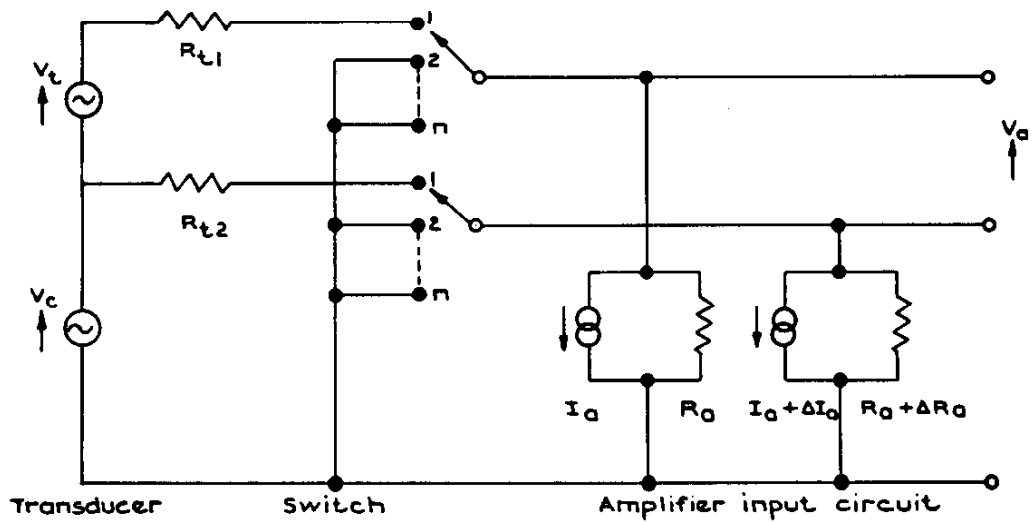


Fig.9 Model of differential switch and amplifier

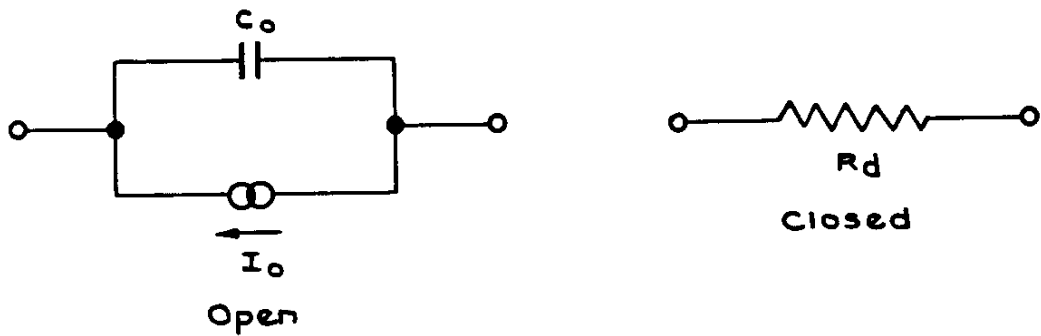


Fig.10 Equivalent circuit of a switching element

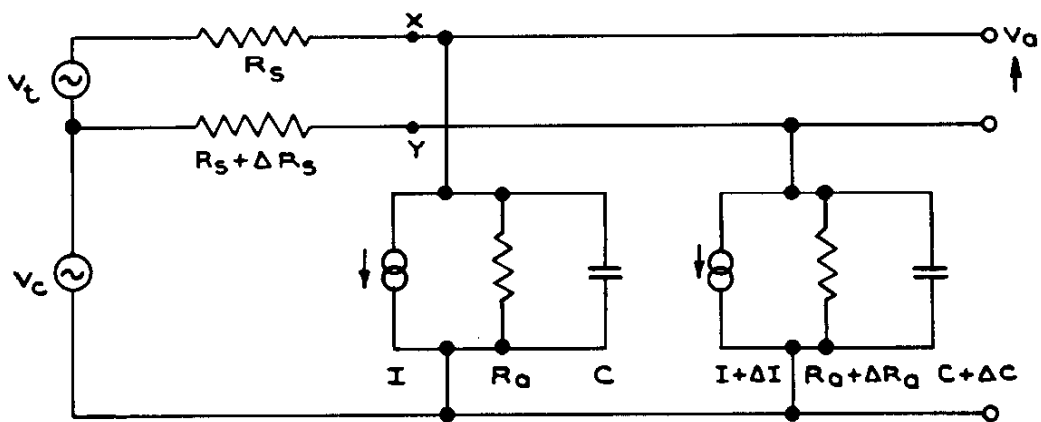
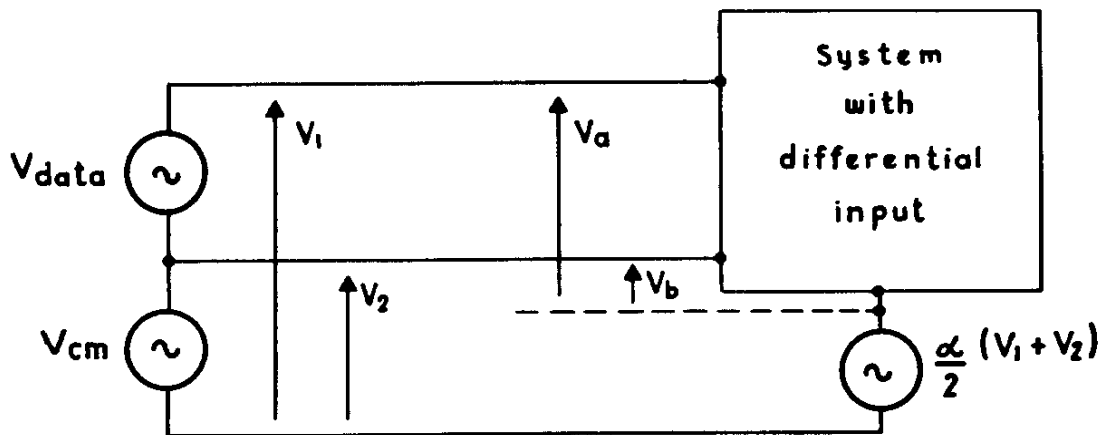
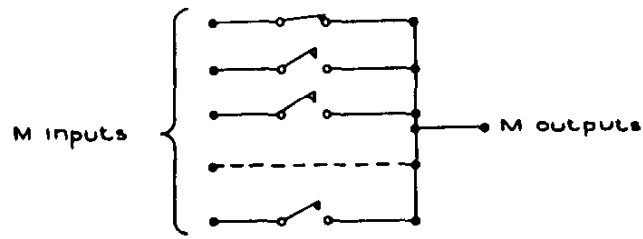


Fig.11 Equivalent circuit of a differential switch and amplifier

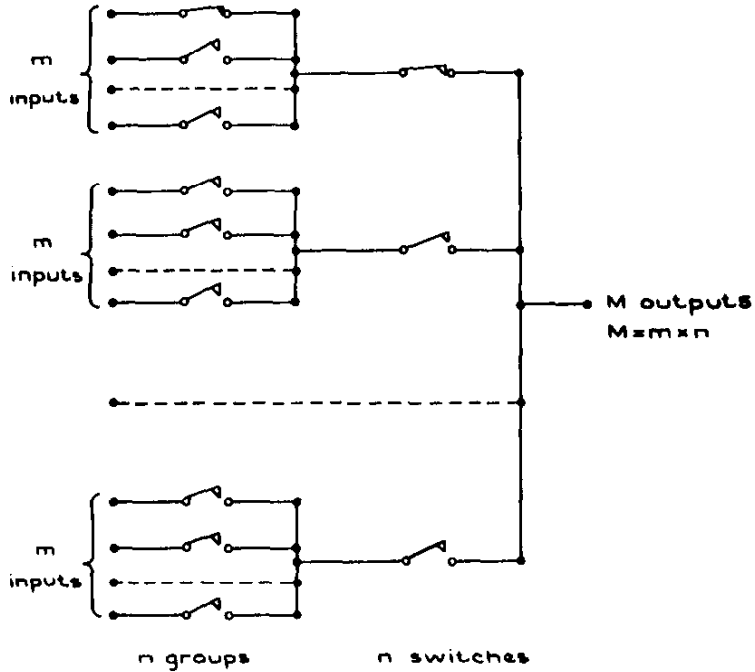


$$\begin{aligned} \text{Effective common-mode voltage} &= \frac{V_a + V_b}{2} \\ &= \frac{(1-\alpha)(V_1 + V_2)}{2} \end{aligned}$$

Fig.12 Reduction in common-mode error by boot-strapping



a Single tier configuration



b Double tier configuration

Fig.13 a&b Multiplexer configurations

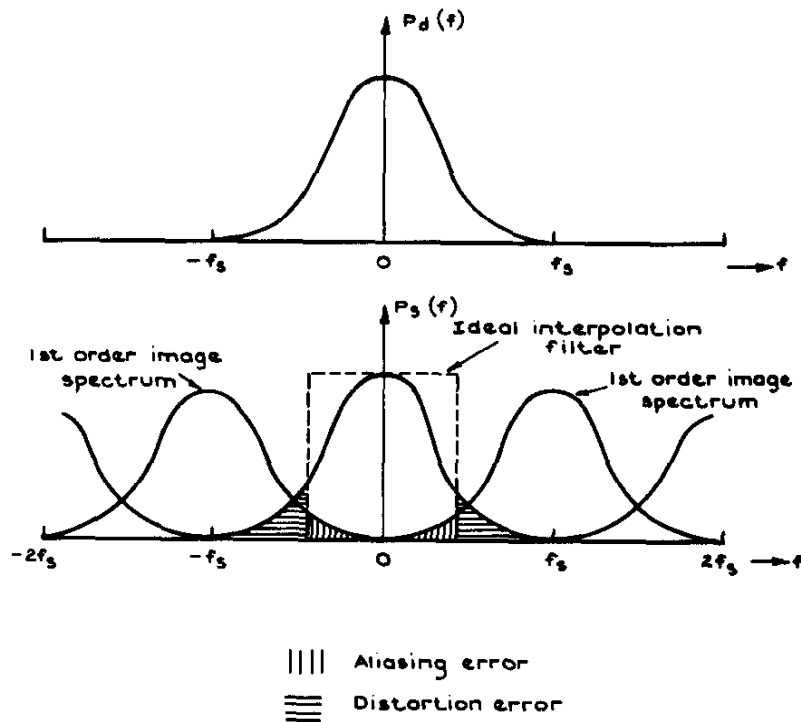


Fig.14 Unsampled and sampled power spectra

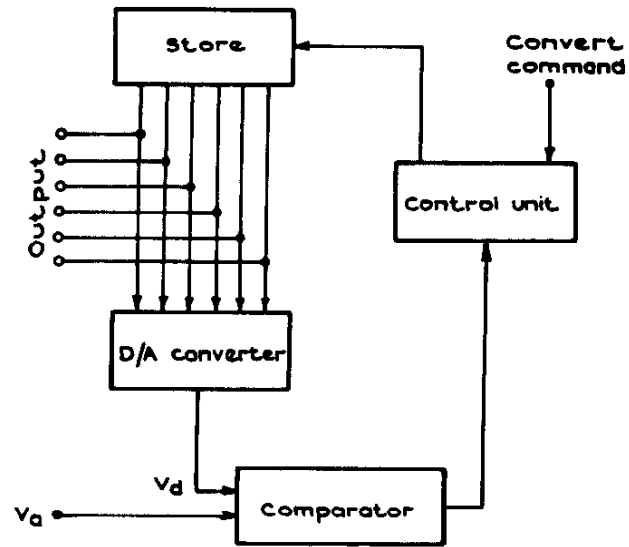


Fig.15 Basic feedback analogue/digital converter

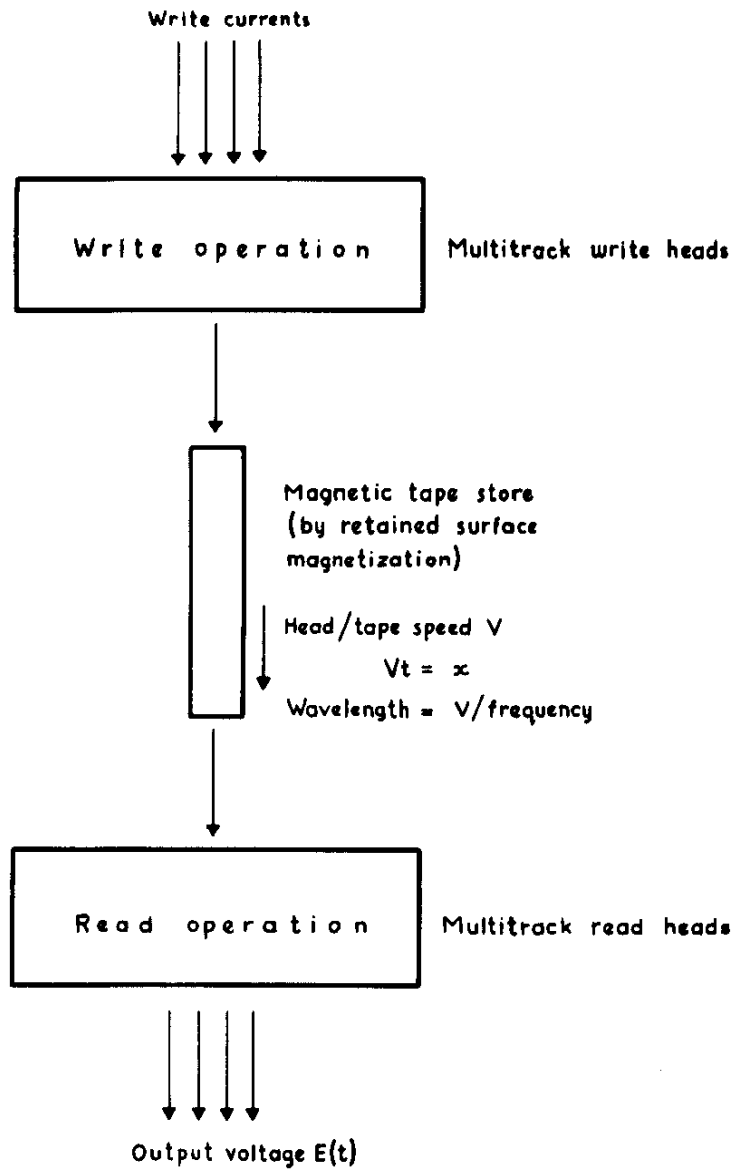
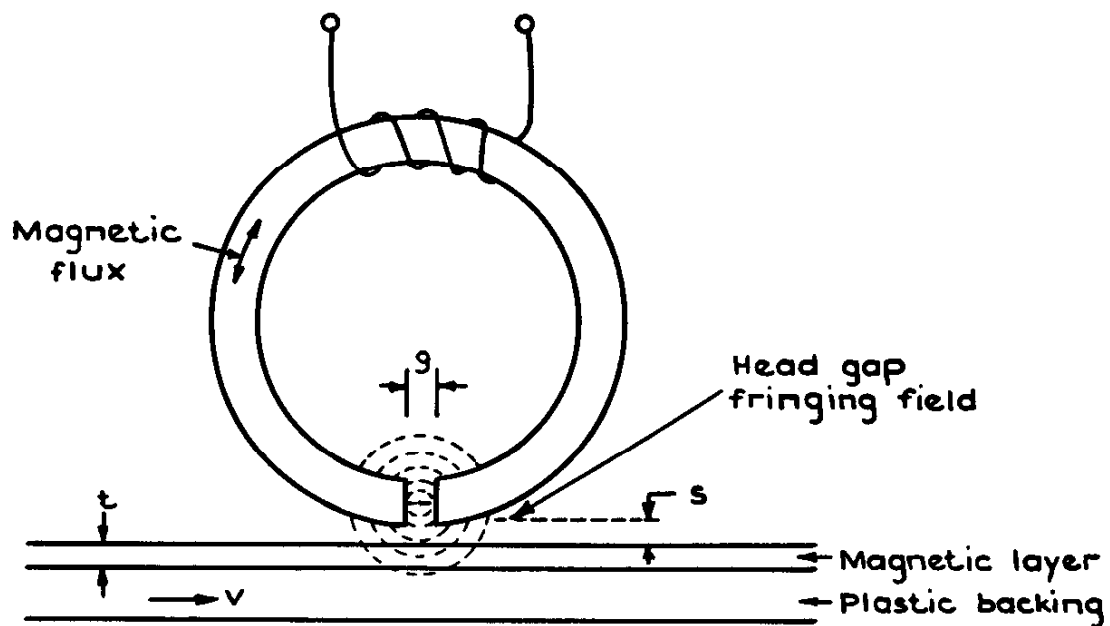
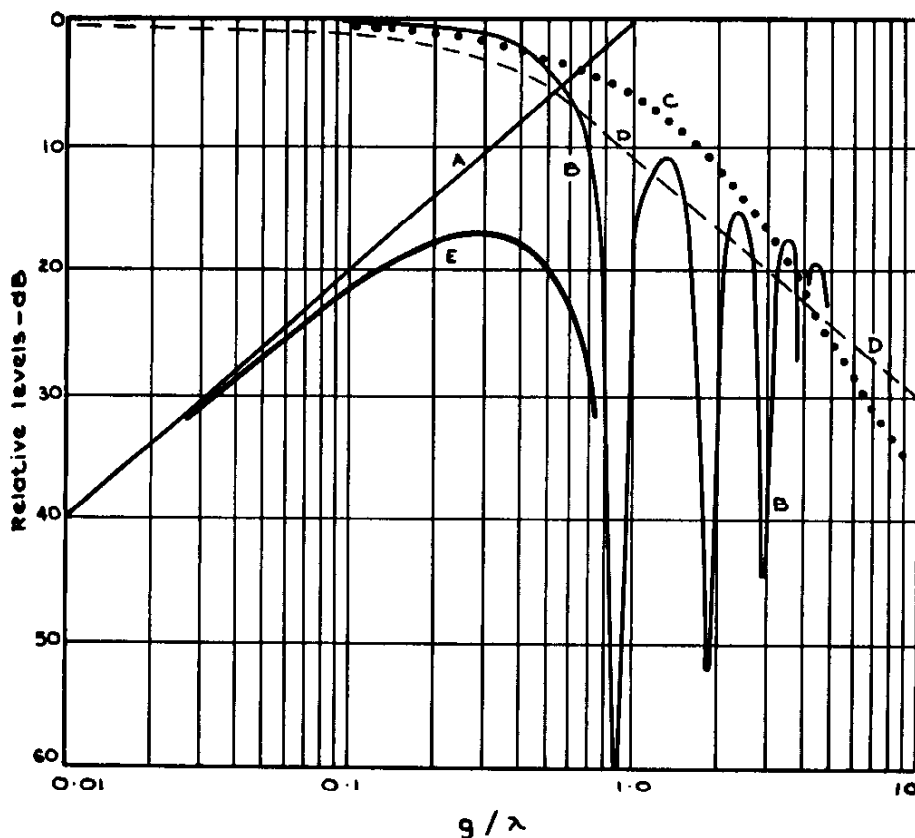


Fig.16 Representation of the magnetic recording process



g = Gap length s = Head-to-surface spacing
 t = Thickness of recording layer

Fig.17 Head/tape relationship for ring-type head



A: Ideal response
 B: Gap loss
 C: Separation loss (for $s = 0.1g$)
 D: Thickness loss (for $t = 0.5g$)
 E: Overall response

Fig.18 Frequency response curves for magnetic recording process

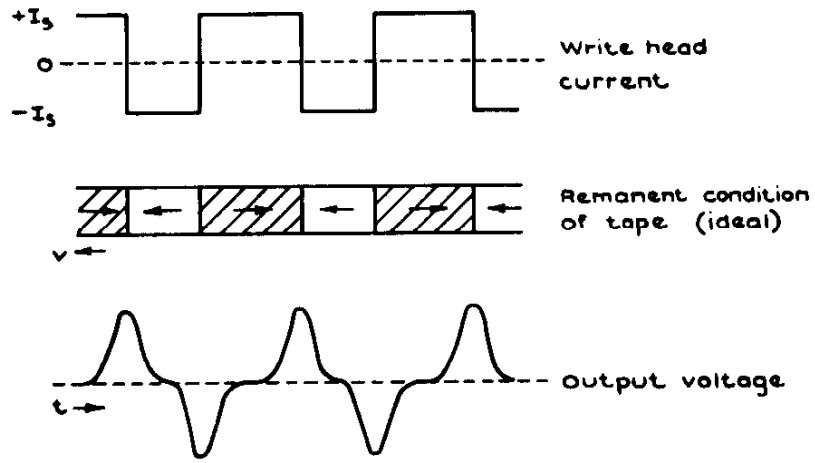
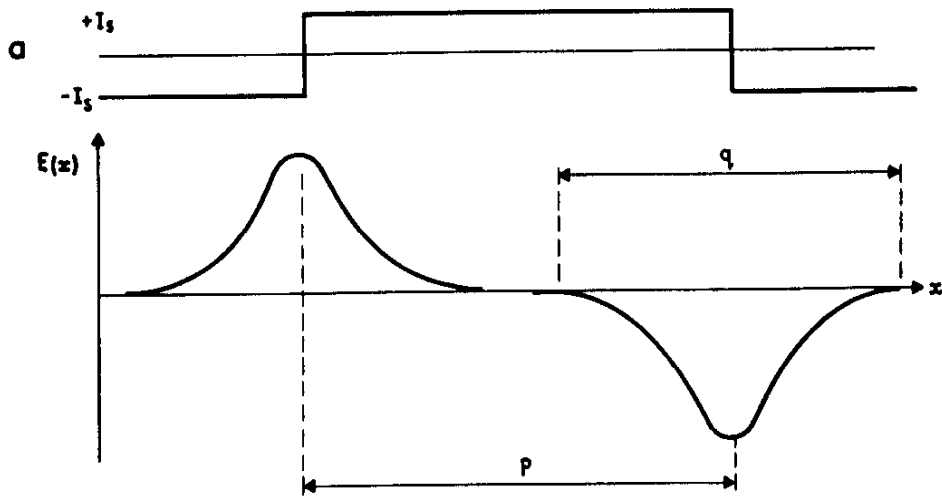
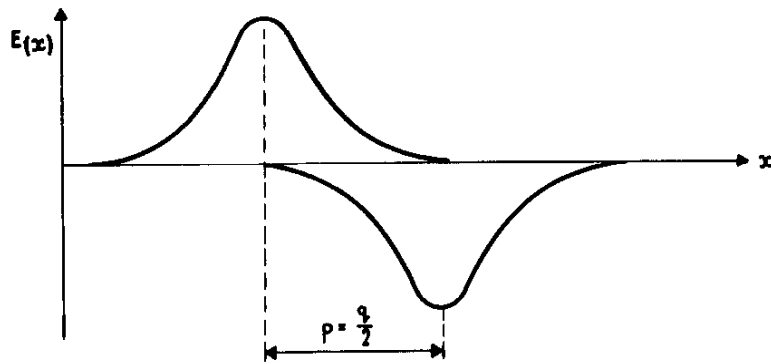


Fig.19 Digital recording transitions



b Low packing density - no pulse crowding



c High packing density with pulse crowding

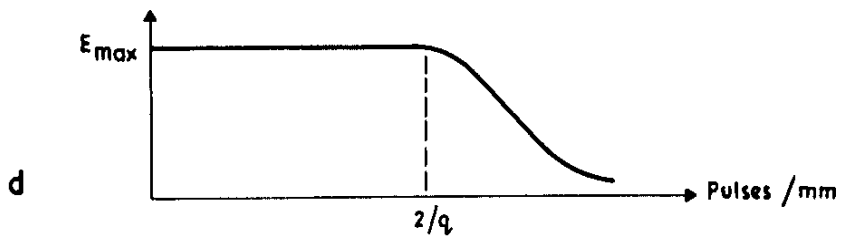


Fig.20 Pulse crowding

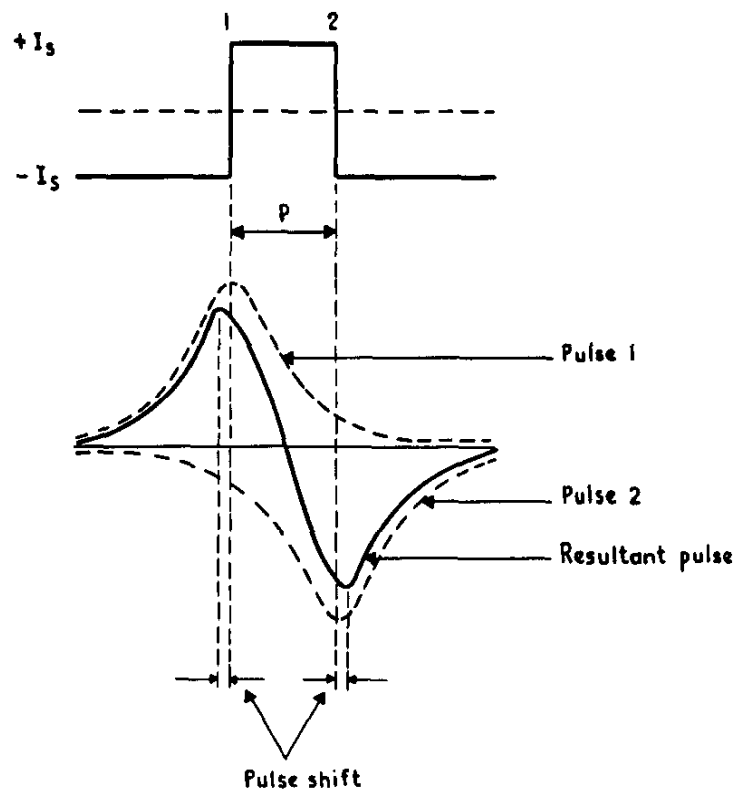
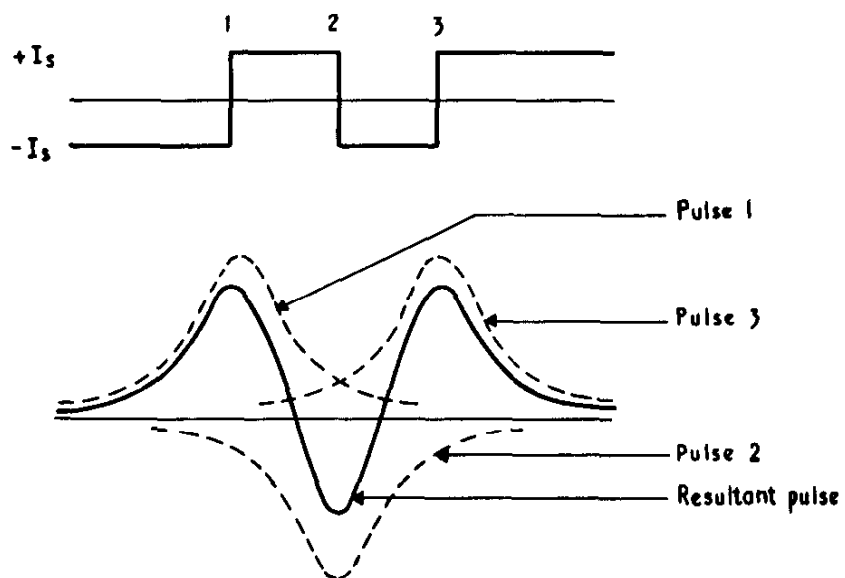


Fig.21 Superposition of two adjacent saturation reversals



Effects : greater attenuation of centre pulse;
base-line shift

Fig.22 Superposition of three saturation reversals

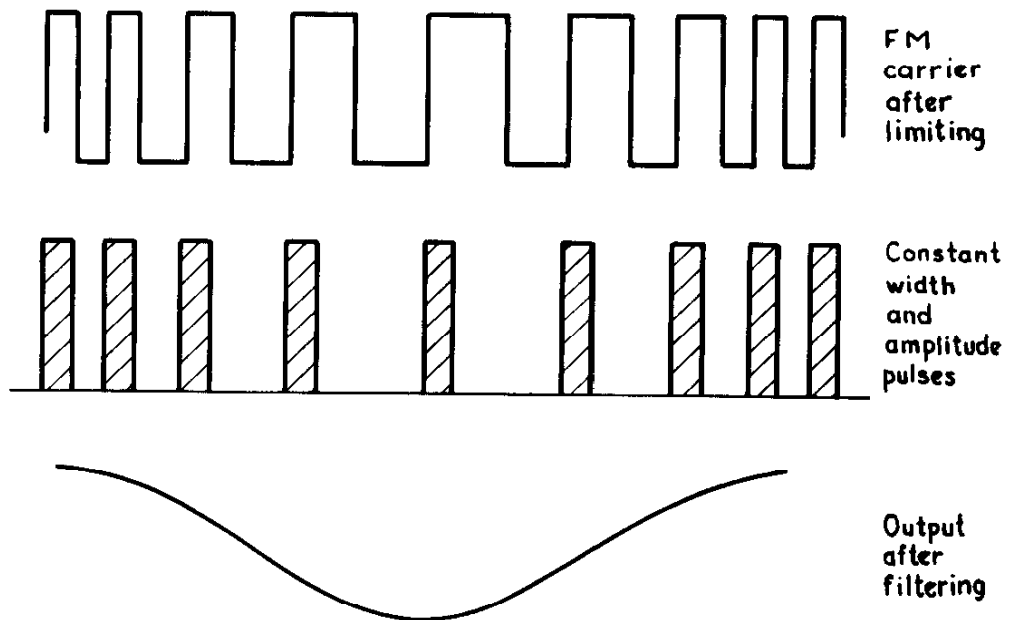
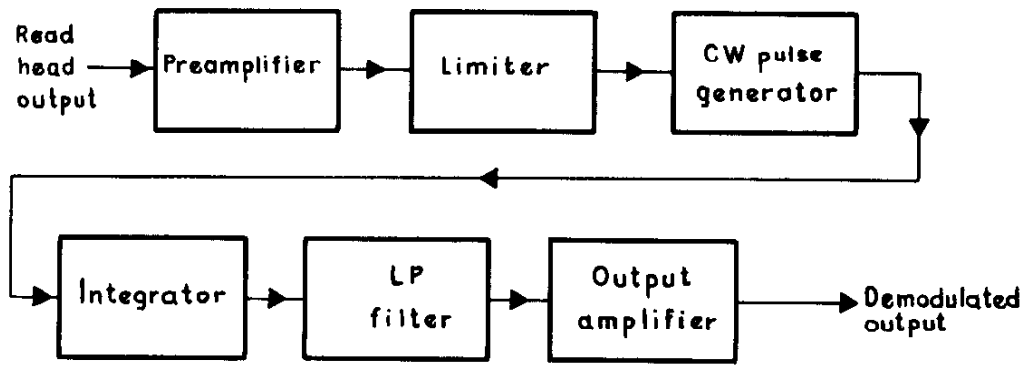
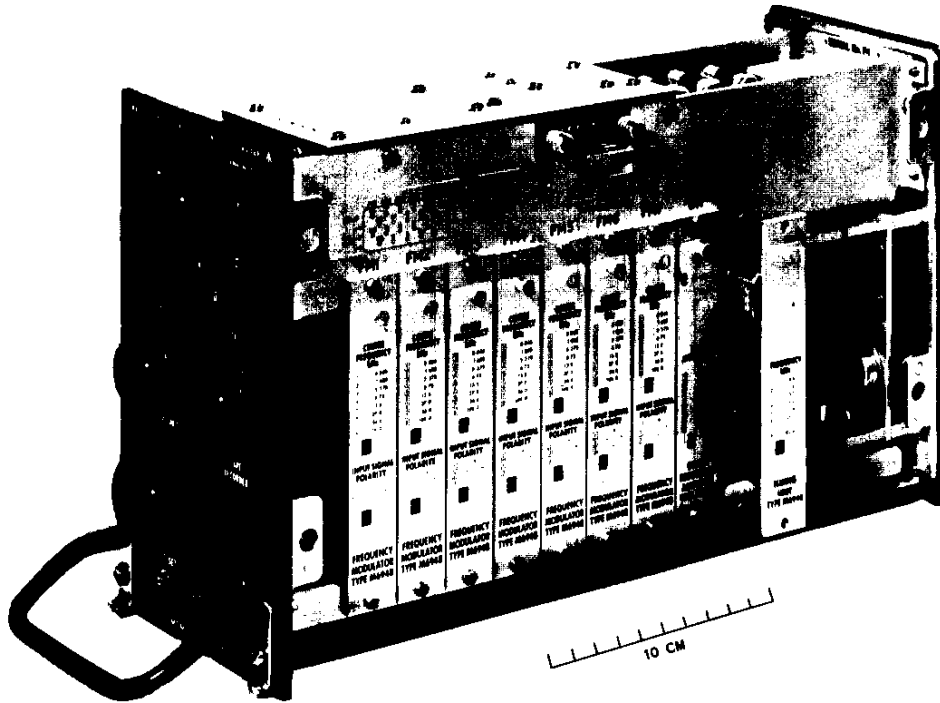
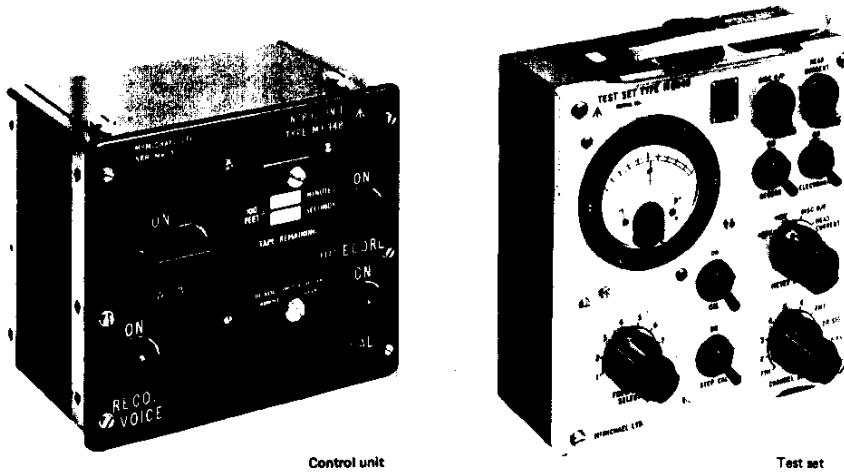


Fig.23 Pulse type FM discriminator



7 FM channels — all speeds (with direct record interrupt facility on one) plus reference channel in half ATR short case



Control unit

Test set

Fig.24 Airborne package of single-carrier FM record electronics (manufactured by McMichael Ltd.)

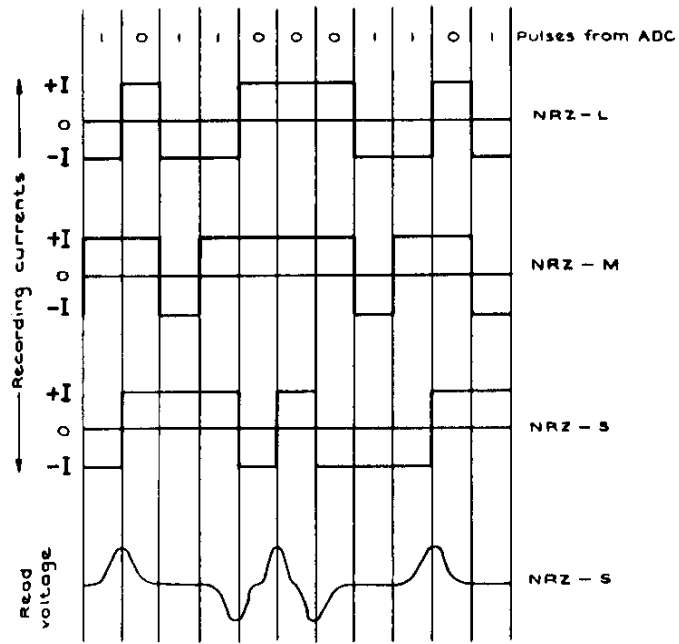


Fig.25 Non-return-to-zero recording waveforms

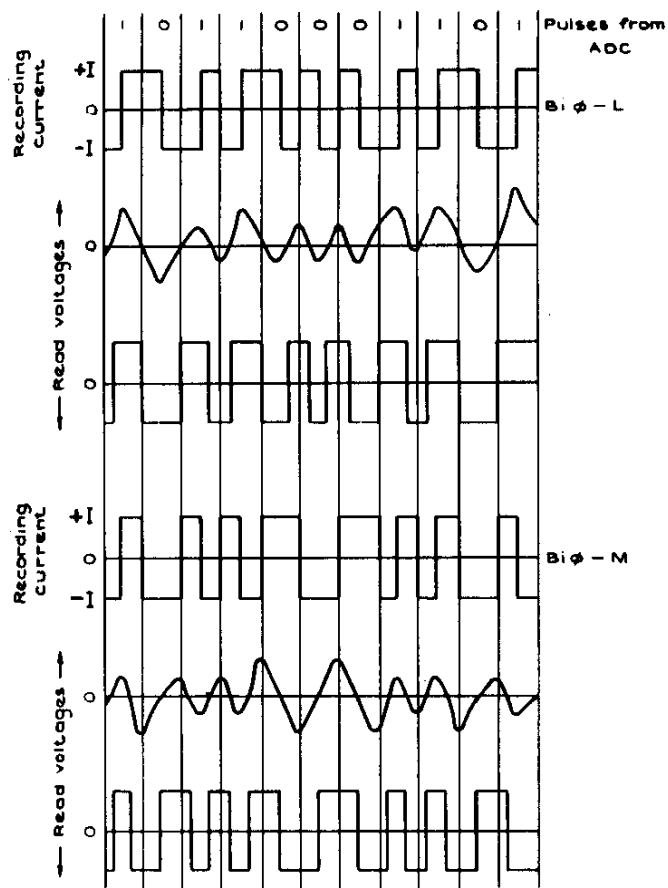


Fig.26 Phase modulation waveforms (Biφ-L and Biφ-M)

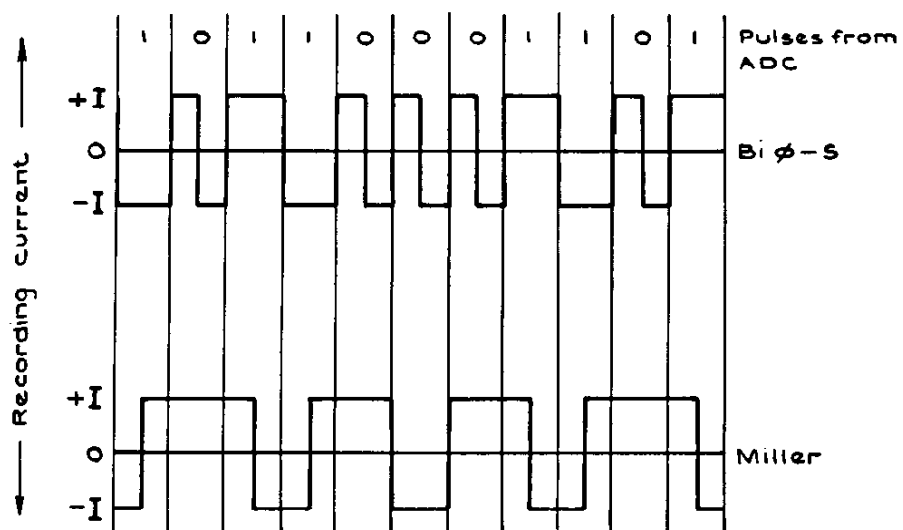
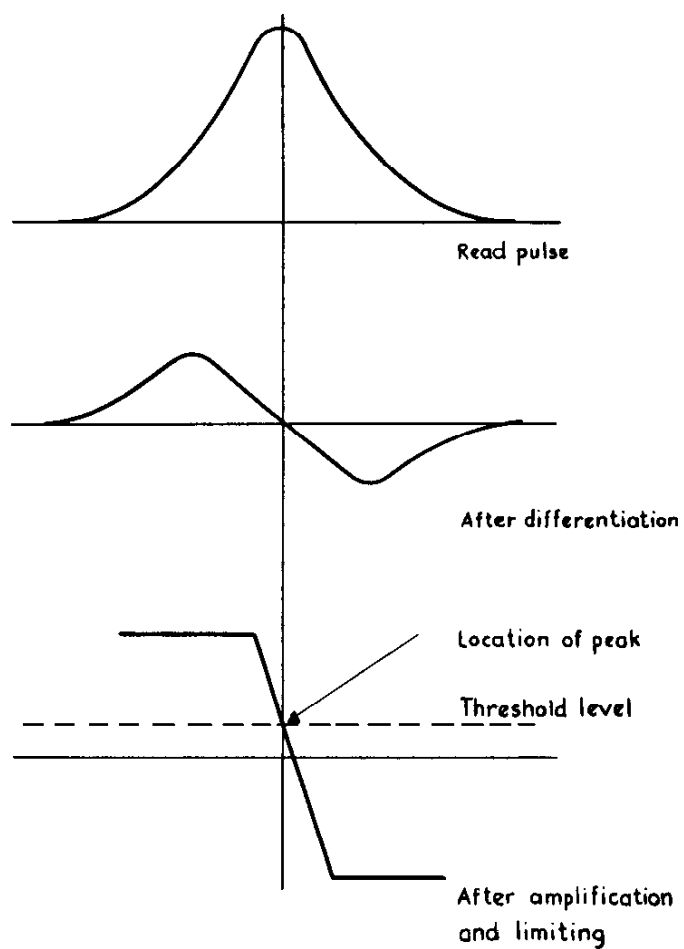
Fig.27 Bi ϕ - S and Miller codes

Fig.28 Peak sensing of the read pulse

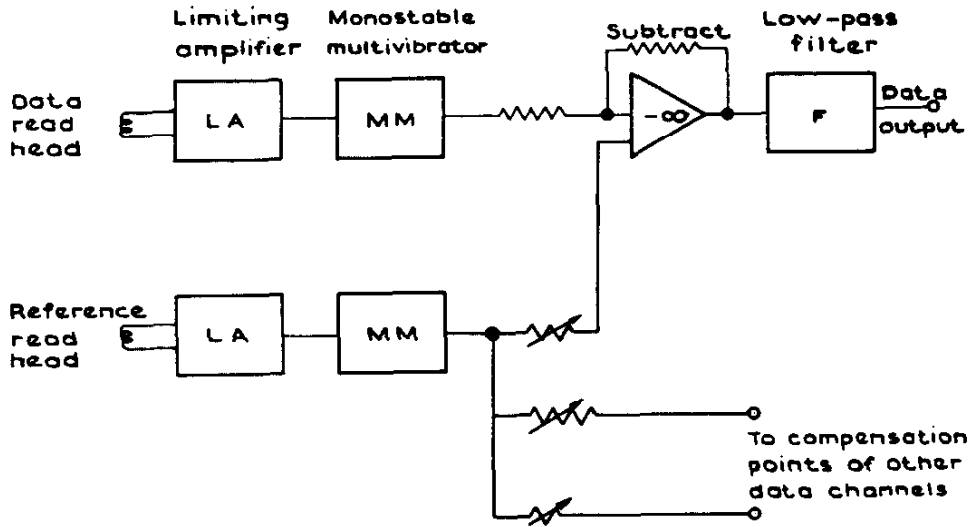


Fig.29 FM demodulation with subtractive compensation

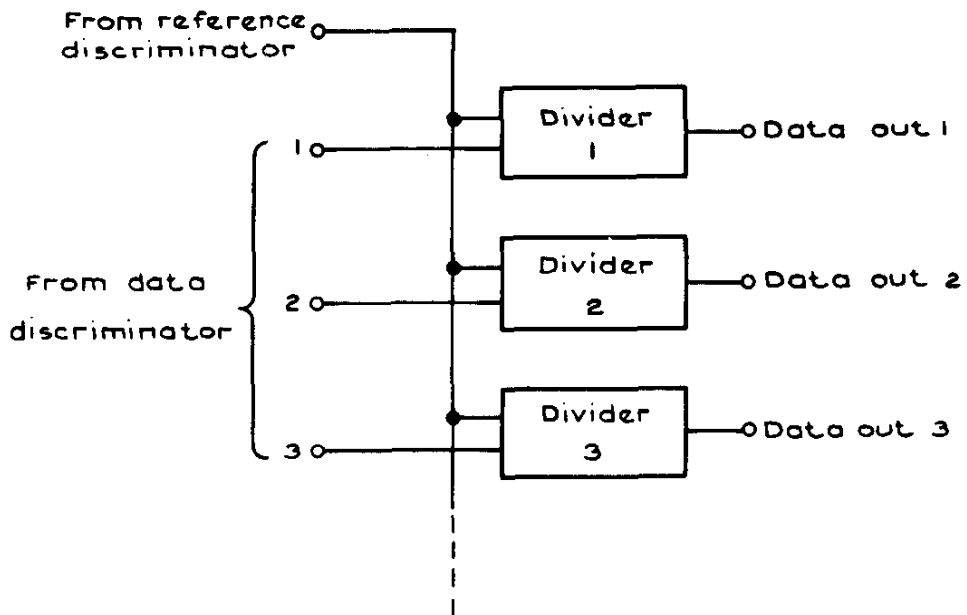


Fig.30 Multiplicative compensation of FM data

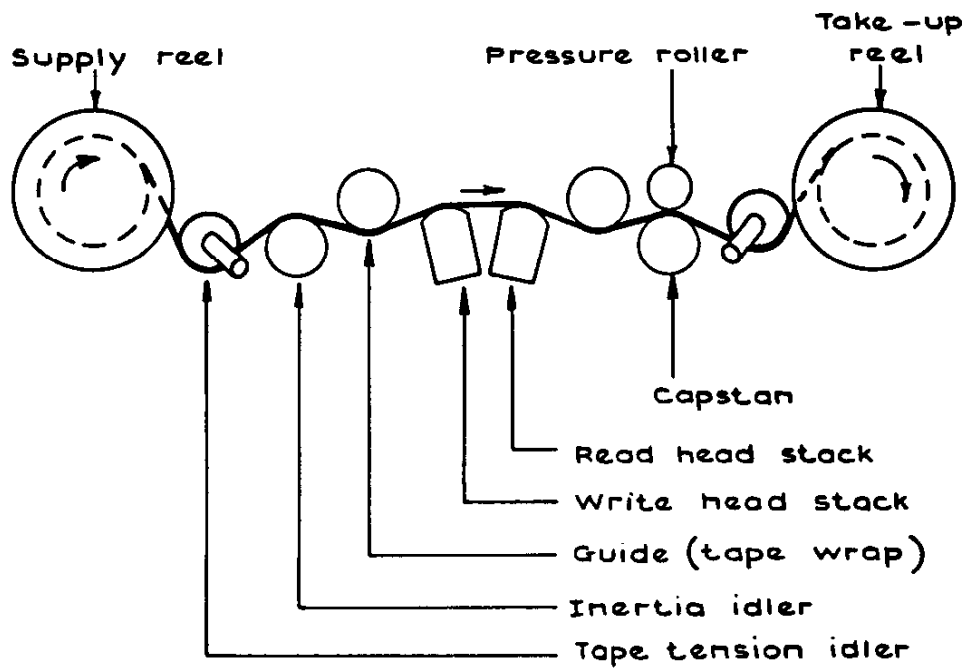


Fig.31 Open-loop drive system

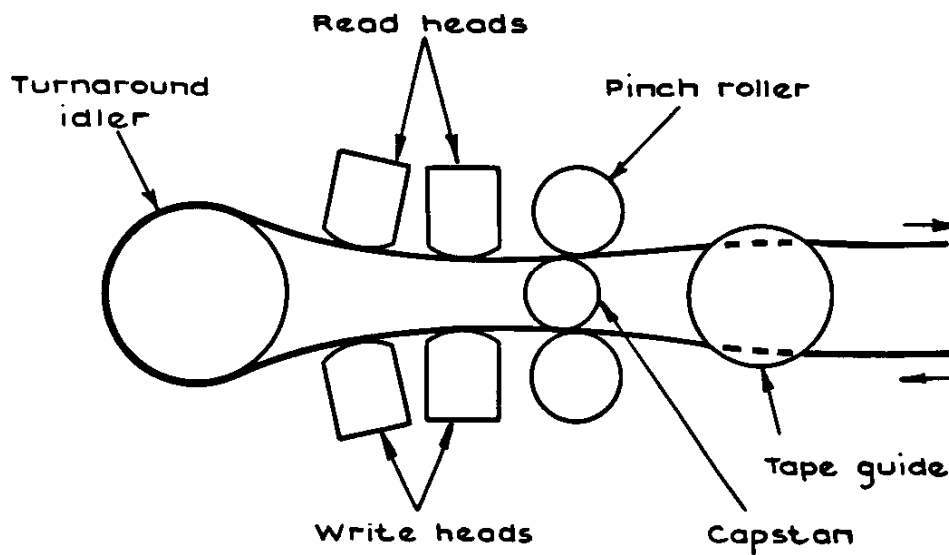


Fig.32 Closed loop drive system

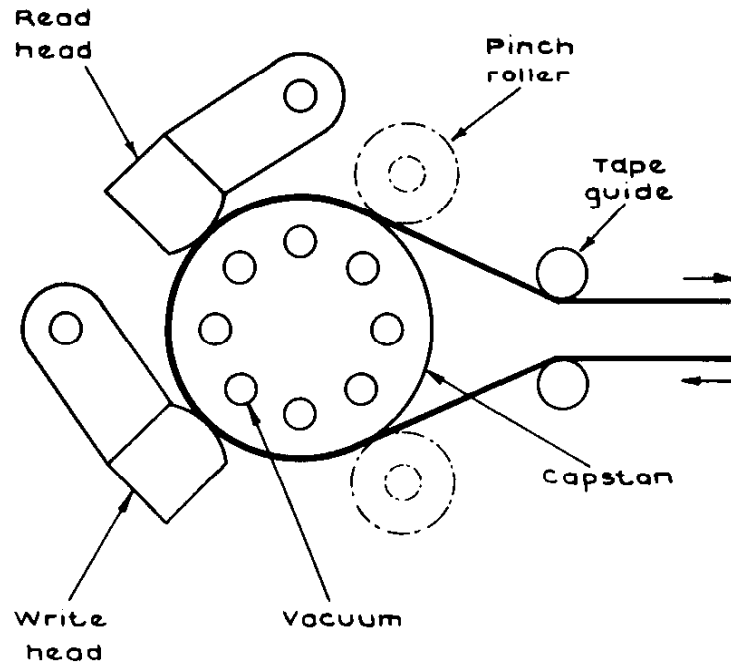


Fig.33 Zero-loop drive system

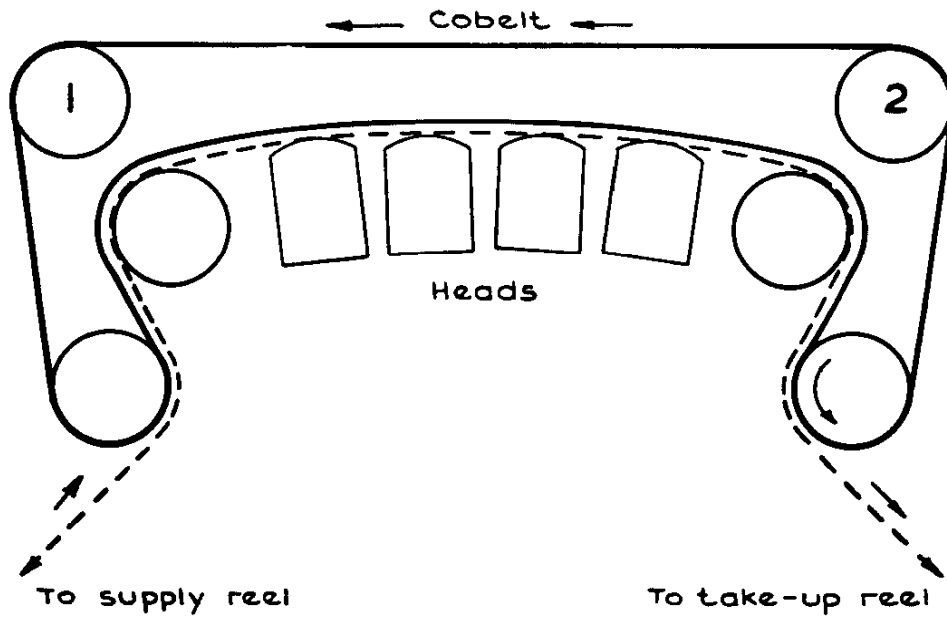


Fig.34 Cobelt drive system

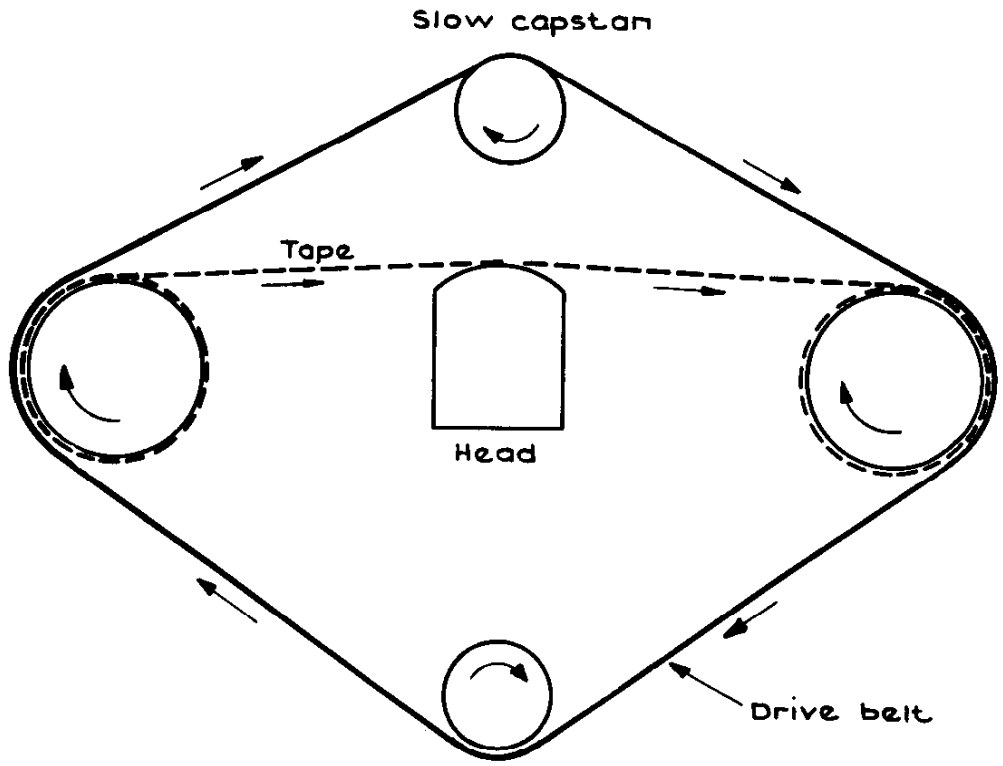


Fig.35 ISO-elastic drive system

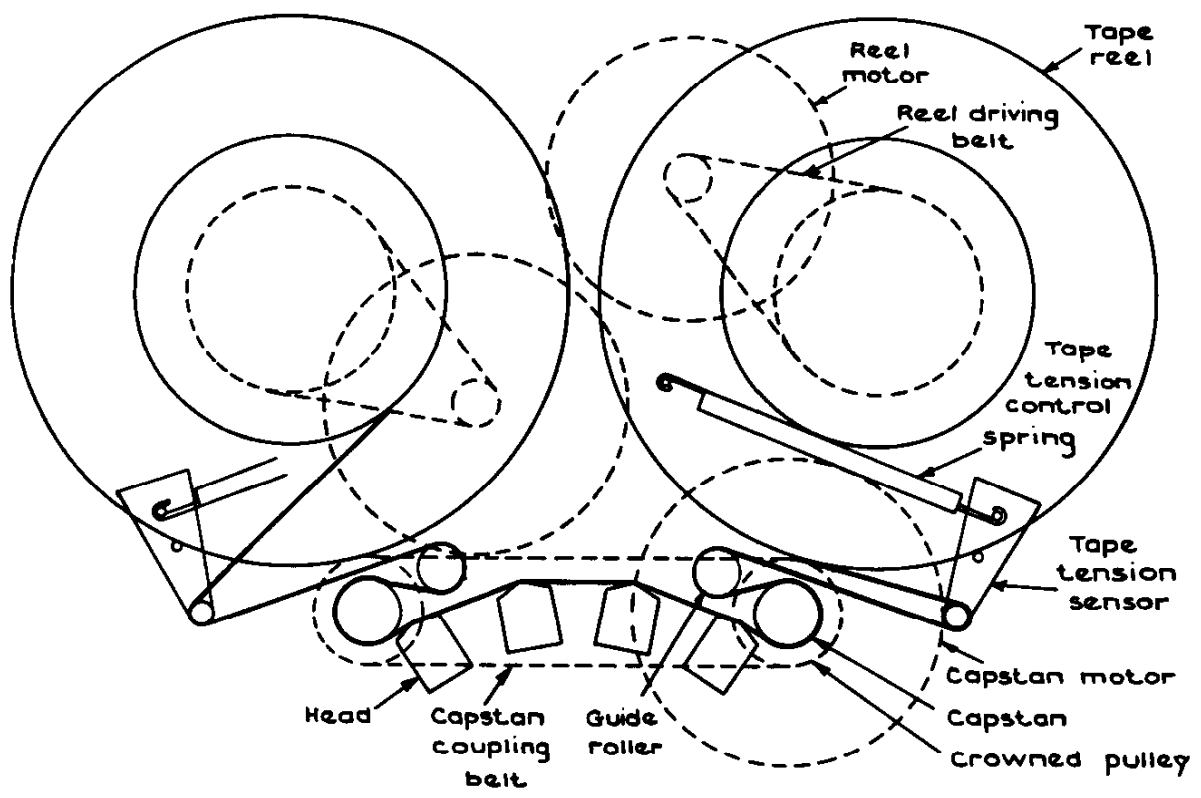


Fig.36 Dual - capstan drive system

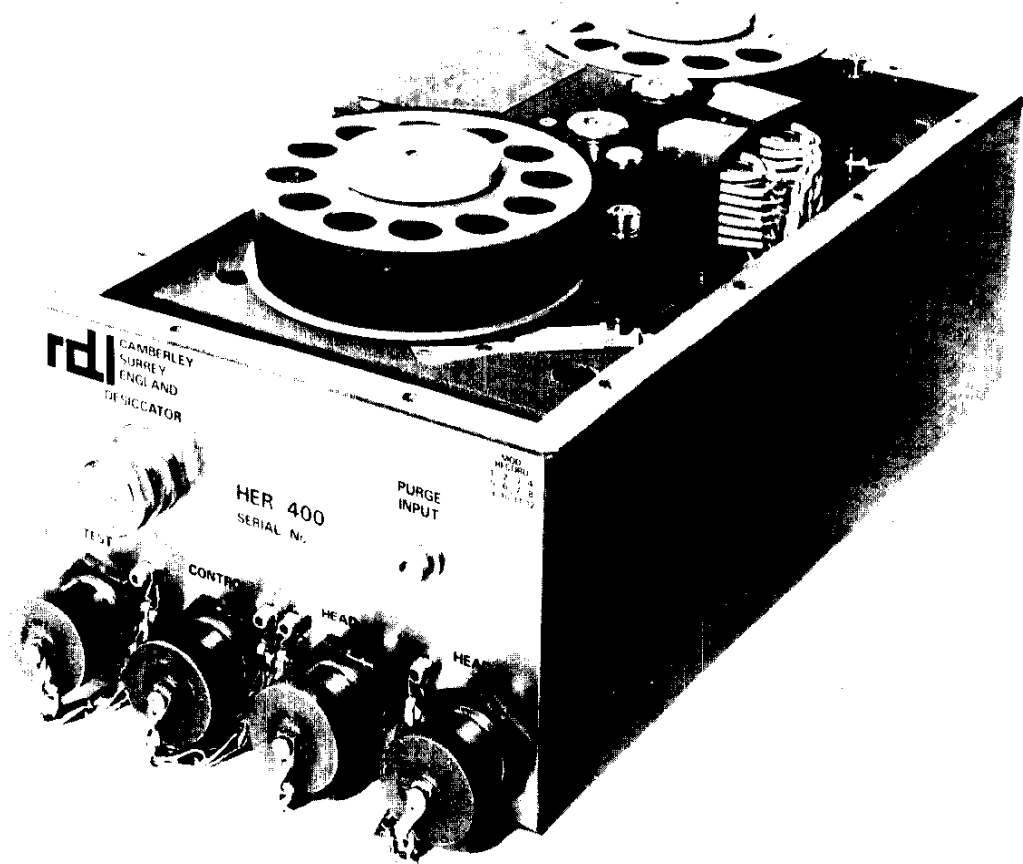


Fig.37 Airborne tape transport with dual capstan drive

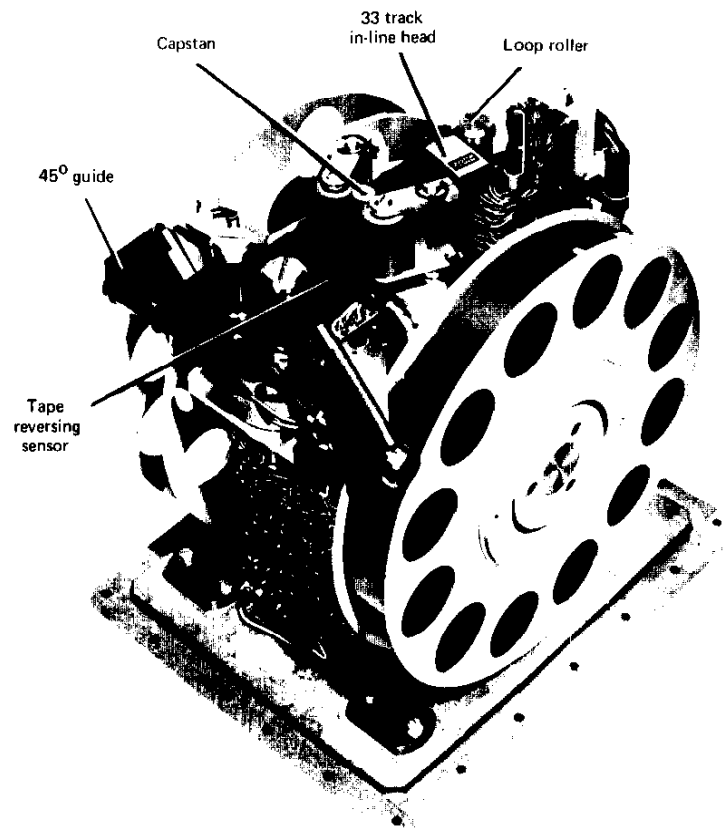


Fig.38 Airborne tape transport - coaxial reel configuration (20.32cm reels)

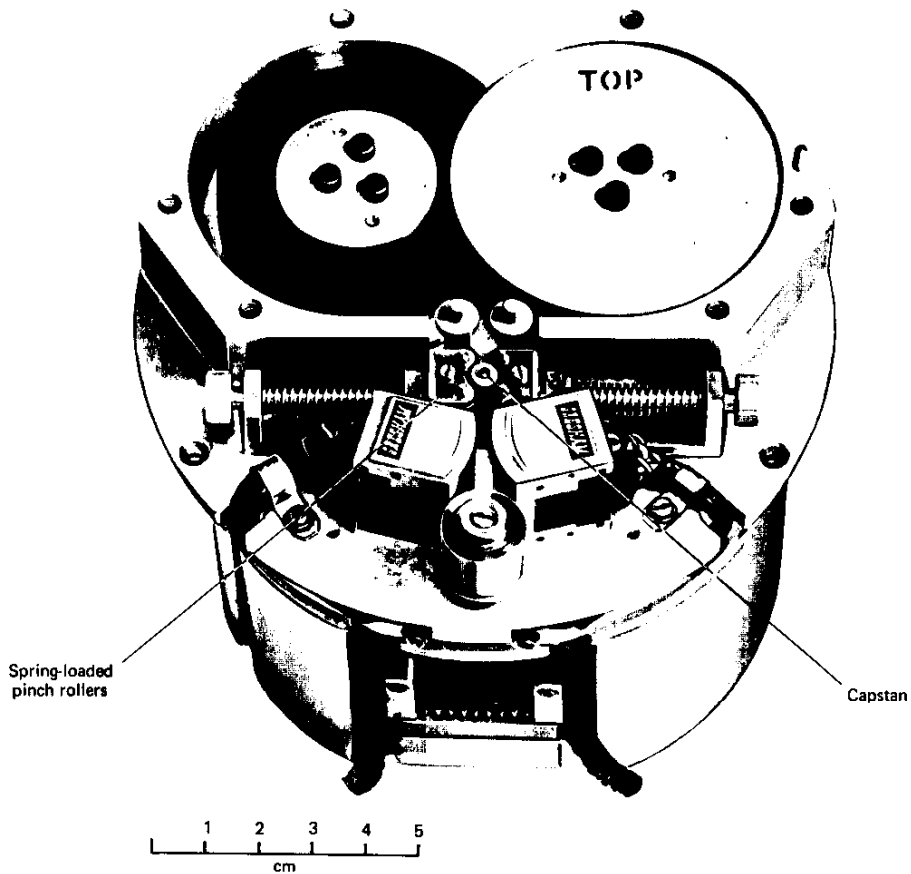


Fig.39 Weapon-borne transport with integral power unit

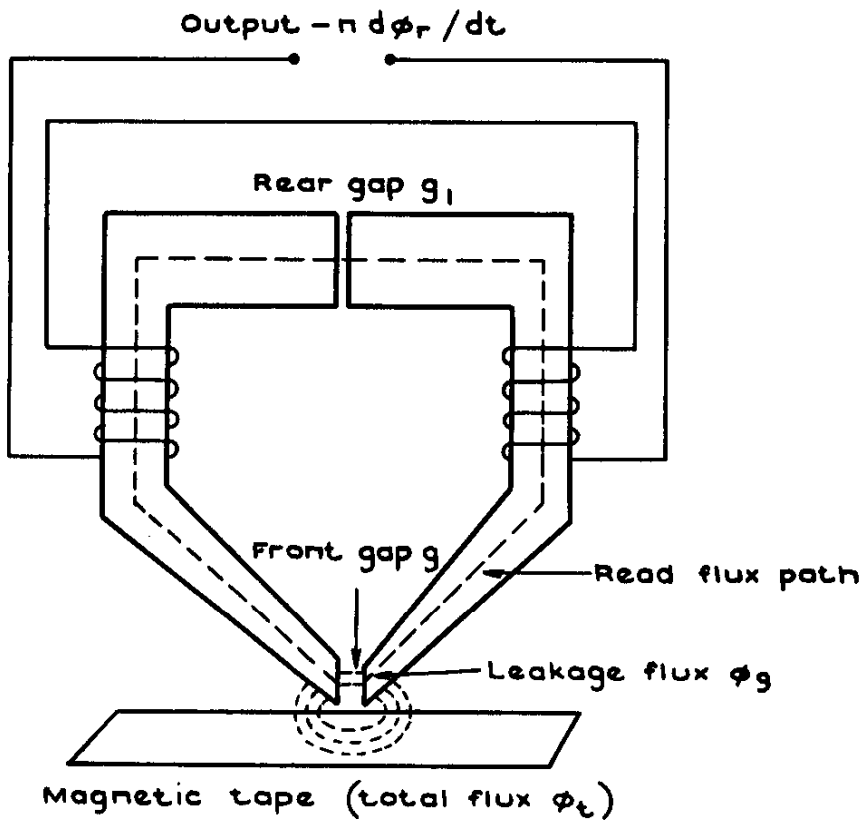


Fig.40 Read head operation

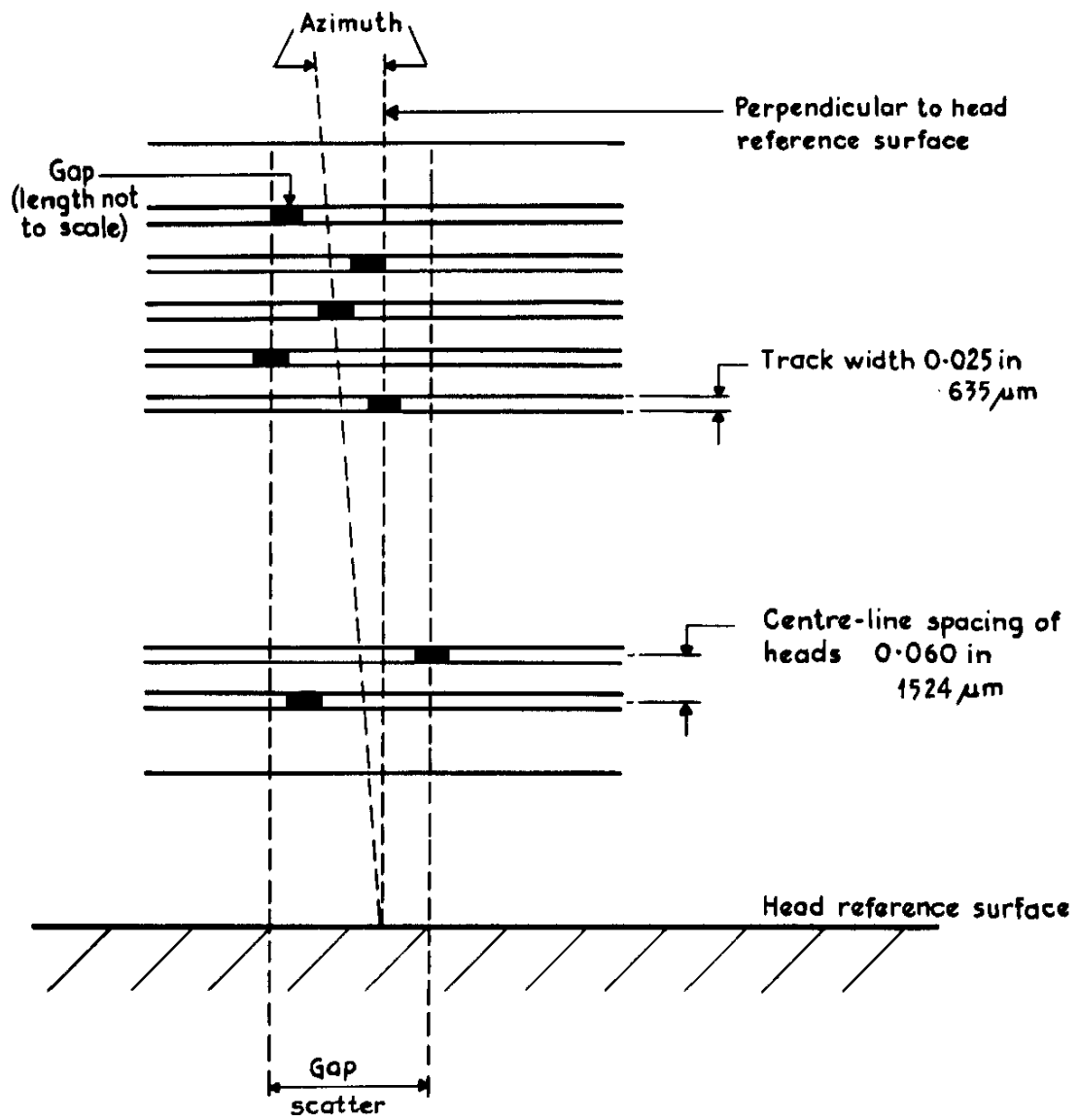


Fig.41 16-Track 25.4mm digital head showing azimuth and gap scatter