

Introduction to Radar Signal & Data Processing: The Opportunity

A. Farina

SELEX Sistemi Integrati

(Formerly AMS SpA)

Director of Analysis of Integrated Systems Group

Via Tiburtina Km. 12.400

00131 Rome

ITALY

e.mail: afarina@selex-si.com

Key words: radar, signal processing, data processing, adaptivity, space-time adaptive processing, knowledge based systems, CFAR.

1. SUMMARY

This paper introduces to the lecture series dedicated to the knowledge-based radar signal and data processing. Knowledge-based expert system (KBS) is in the realm of artificial intelligence. KBS consists of a knowledge base containing information specific to a problem domain and an inference engine that employs reasoning to yield decisions. KBS have been built: some are very complex with thousands rules while others, relatively simple, are designed to tackle very specialised tasks. This lecture series shows that KBS can be successfully applied to radar systems. This paper introduces the Reader to the world of radar and, specifically, to the topics tackled in the subsequent lectures of the series. The paper starts with an introduction (Section 2) to radar (radar evolution from the early days up today, taxonomy of radar and radar equation). Subsequently, Section 3 considers the schematic of a modern radar system. The phased-array radar is the theme of Section 4. Signal processing, one of the main building blocks of modern radar, is introduced in Section 5. The section also introduces to the various forms of adaptivity in time, space and space-time domains for natural and intentional interference mitigation. Data processing, mainly target tracking, (Section 6) is the other relevant building block of radar. An extensive list of references (Section 9) is helpful to the Reader for a deeper insight to the many interesting topics of radar.

2. INTRODUCTION

2.1 Radar Evolution

RADAR (Radio Detection And Ranging) story dates back to H. Hertz (Ge), 1885-1888. He experimentally verified the prediction of J. Maxwell's theory of e.m. field published in 1864. He used an apparatus operating at 455MHz similar to a pulsed radar. Subsequently C. Hulsmeyer (Ge) in 1904 had a patent for a monostatic pulse radar. He envisioned the detection of ship for preventing collision at sea. In 1920 G. Marconi (It) observed the radio detection of targets in his experiments. He strongly urged its use in a speech delivered in 1922 at the Institute of Radio Engineers (now IEEE). In 1922 A. Hot et al. (NRL, USA) observed a fluctuating signal at the receiver (RX) when a ship passed between the receiver and the transmitter (TX) located on

Farina, A. (2006) Introduction to Radar Signal & Data Processing: The Opportunity. In *Knowledge-Based Radar Signal and Data Processing* (pp. 1-1 – 1-24). Educational Notes RTO-EN-SET-063 (2006), Paper 1. Neuilly-sur-Seine, France: RTO. Available from: <http://www.rto.nato.int/abstracts.asp>.

opposite sides of a river; it was a bistatic CW (continuous wave) radar. Noticeable was in 1940 the British invention (University of Birmingham) of high power micro-wave (μw) magnetron for higher frequency for radar. More details on the radar history can be found in [1] from which the previous notes are taken.

During world war II (WWII) the development of radar had a boost. **USA (1941)**. Over one hundred radar (operating at 200MHz) were delivered to US Navy. Over one hundred radar (at 100MHz) were delivered to US Army for long range air search. One of these detected the Japanese attack on Pearl Harbour. Development of μw radar during WWII was done at MIT Radiation Lab and Bell Telephone Labs. During WWII Radiation Lab developed many different radar types. **Germany (end 1940)**. Three major operational radar were developed: 125 MHz Freya air search radar; Wurzburg fire control radar at 565 MHz: 4000 units were produced; Seetack (500MHz) ship-borne radar: 100 units were produced. The first operating radar at 30MHz for the Home Chain was developed in **UK (1938)**. **USSR (in 1940)**. RUS-1: bistatic CW at 75MHz with 35Km separation between TX and RX. RUS-2: monostatic pulse system at 75MHz [1], [2]. **Italy (end '30, beginning '40)**. Prof. U. Tiberio gave a substantial contribution to the development of the radar equation [3]. The Owl was the name of the radar developed at that time; it was a 200 MHz ship-borne radar; more than 40 units produced. Activities during WWII were also done in **Japan, France and The Netherlands** [1].

The list of some major accomplishments of radar after WWII are the following (for details see [1] and [4]). Use of Doppler effect in MTI (Moving Target Indication) pulse radar to separate desired target echoes from undesired clutter echo. High power stable amplifiers (klystron, travelling wave tube, solid state transistors) allow better application of Doppler effect, use of sophisticated waveforms, and much higher power. High accurate angle tracking is achieved with monopulse radar. Pulse compression is a technique that uses long waveforms to obtain high energy and, at same time, achieves resolution of a short pulse by internal modulation of the long pulse and suitable processing of the received echoes. SAR (Synthetic Aperture Radar) obtains high resolution map like for imaging of ground scene; ISAR (Inverse SAR) is adopted for imaging of targets and planets. Carl Wiley of Goodyear Aircraft Corporation theorised SAR in 1951 [5]. The first demonstration was on board an aircraft in '50s; for a comprehensive introduction to SAR, see [6]. Interferometric SAR allows the generation of the digital elevation model (DEM) of sensed scene; remarkable the Shuttle radar imaging topographic mission (1999). Airborne MTI and pulse Doppler radar is able to detect target in the midst of heavy ground clutter. Electronically steered phased-array permits rapid beam steering without mechanical movement of antenna. HF over the horizon radar detects targets up to 2000nm. Non Cooperative Target Recognition (NCTR) techniques are based on high range resolution radar, ISAR, jet engine modulation, polarimetry and a combination of the above techniques. Radar is also exploited by meteorologist and for aid for safe and efficient air travel (air traffic control). Space based radar is used for surveillance and remote sensing of the globe [7] and for planetary exploration. Rapid advances in digital technology have made many theoretical capabilities practical with digital signal and data processing; few remarkable examples follow. Adaptivity at antenna level for jammer cancellation (1957, P. Howells, GE Syracuse; 1959 patent on Side Lobe Canceller; S. Applebaum: technical report on adaptive arrays). For a story of adaptivity see [8]. STAP (Space Time Adaptive Processing): invented by F. Dickey (GE), F. Staudaher (NRL), M. Labitt (MIT-Lincoln Laboratory) in 1991; they received the IEEE AESS Pioneer award for development, starting in 1950's, of airborne moving target systems particularly as used in the US Navy E2 series of aircraft [9]. A vision of opportunities for modern radar is described in [10]; [11] is a remarkable report on the MIT-LL developments in radar in the last 50 years.

A more recent major advance in modern radar is the application of KBS technology. Knowledge and expert rules may be used to select the radar operation mode, the algorithms and training data thereby significantly improving the performance of modern adaptive array radar in dynamic and non homogeneous environment. Sources of data are: digital terrain model, surface cover, geographic maps, meteorological condition, data

from other sensors, etc. It is expected that the knowledge about local radar environment will enhance the ability of radar to maintain multiple tracks through areas of shadowing, clutter and other sources of interference that might be present in the surveillance scene [52].

Here a possible adaptive signal processing application example. KBS addresses the actual environment and performs better than conventional algorithms that hypothesize iid (identical independently distributed) conditions for clutter data. KBS ensures that shadowed range cells are excluded from training data. KBS based processor using information from diverse sources determines the choice of data also to best match the interference scene [52]. Other possible applications of KBS refer to STAP, to tracker (it is based on a number of rules: maneuver/obstacle rule, shadow rule, discrete rule, etc.). Study cases of KBS applied to radar systems, which are discussed during this Lecture Series, are: general radar problems, CFAR (Constant False Alarm Rate), tracking, STAP, and phased-array radar system.

Techniques, technologies, systems and applications of radar are extensively described in many papers, books and conference proceedings. IEEE Trans. on Aerospace and Electronic Systems and IEE Proc. Radar, Sonar and Navigation are some of the key reference journals. Several are the books published on radar; the following is a not exhaustive list: [12] to [15]. Regular international radar conferences are managed on a five year cycle by IEEE and IEE, with an interlace of long standing conferences organized in France, China, Japan, Germany, India and, more recently, in Australia. Thus a wealth of top quality technical publications are available to radar scientists, engineers, students, practitioners, managers and users.

2.2 Taxonomy of Radar

This may be in terms of:

- 1) Location of radar: ground-based (fixed/transportable/mobile), ship-borne, air-borne, space-borne;
- 2) Function: surveillance, tracking, reconnaissance, imaging, data link;
- 3) Application: air traffic control (terminal area, en route, collision avoidance, apron), monitoring of surface traffic in the airports (taxi radar), air defence, anti theatre ballistic missile defence, vessel traffic surveillance, remote sensing (application to crop evaluation, hydrology, geodesy, archaeology, astronomy, defence), meteorology (hydrology, rain/hail measurement), study of atmosphere (detection of micro-burst and gust, wind profilers), space-borne altimetry for measurement of sea surface height, acquisition and tracking of satellites in the re-entry phase, monitoring of space debris, anti-collision for cars, ground penetrating radar (geology, gas pipe detection, archaeology, detection and location of mines, etc.);
- 4) Band (see [16]); criteria for frequency selection for surveillance radar are in [17]; criteria for frequency selection for an advanced sensor suite for US Navy are discussed in [18];
- 5) Beam scanning: fixed beam, mechanical scan (rotating, oscillating), mechanical scan in azimuth, electronic scan (phase control, frequency control and mixed in azimuth/elevation), mixed (electronic-mechanical) scan, multi-beam configuration;
- 6) Number and type of collected data: range (delay time of echo), azimuth (beam pointing of antenna beam, amplitude of echoes), elevation (only for tri-dimensional – 3D – radar, multifunctional, tracking), height (derived by range and elevation), intensity (echo power), radar cross section – RCS – (derived by echo intensity and range), radial speed (measurement of differential phase along the time on target due to the Doppler effect; it requires a coherent radar), polarimetry (phase and amplitude of echo in the polarisation channels: HH – horizontally transmitted, horizontally received – HV, VH, VV), RCS profiles along range and azimuth (high resolution along range, imaging radar);

- 7) Configuration: monostatic (co-located TX & RX – same antenna, mono-radar/multi-radar), bistatic (not co-located TX & RX – two antennas), multistatic (one or more TX & RX spatially dispersed); suitable references for bistatic, multistatic and passive radar are: [2], [19] to [21];
- 8) Waveform: continuous wave, pulsed wave, digital synthesis;
- 9) Processing: coherent (MTI/MTD/Pulse-Doppler/super-resolution/SAR/ISAR...), non coherent (integration of envelope signals, moving window, adaptive threshold (CFAR)) and mixed; and
- 10) Technologies: for antenna (reflector plus feed, array (planar, conformal), corporate feed/air – coupled/lens), transmitter (magnetron, klystron, TWT, mini TWT, solid state) and receiver (analogue and digital technologies, base band, intermediate frequency sampling, etc.; relevant parameters of receiver are: noise figure, bandwidth and dynamic range).

At this point it is interesting to quote a book containing the radar terminology in English, German and French [22]; the subject oriented glossaries contain more than 1000 main and sub terms with definitions, synonyms, acronyms, contrast terms and cross-references.

2.3 Radar Equation

The radar equation, a main ingredient for radar design, gives the target echo received power as a function of: radar parameters, target, environment and geometry. It compares the power with the radar sensitivity which is a function of: P_d and P_{fa} (i.e.: the required detection and false alarm probabilities) to determine the maximum range at which the target can be detected.

Some of relevant ingredients of the radar equation are: signal-to-noise power ratio (SNR), target radar cross section, target fluctuating models, algorithms and signal processing schemes. The radar equation is widely explained in Ch. 2 of [1]. Different expressions of the radar equation are available for volume search, tracking, presence of clutter and jamming, see chapters 1, 2 and 9 of [12].

3. SCHEMATIC OF A MODERN RADAR SYSTEM

The simplified scheme of a modern radar system is depicted in Figure 1. The major blocks and their corresponding functions are now briefly described.

- **Antenna and Scan Pattern Generator:** this determines the shape and direction of TX/RX beam. The antenna can be either a mechanically rotating reflector or a phased array electronically steered in azimuth and elevation.
- **Transmitter:** it is generally a tube generating a coherent pulse train with high peak power and possibly a wide band; alternatively, mini TWT or solid state amplifiers can be used in active phased-array radar.
- **Waveform Generator:** it tailors the waveform to the environment and to the particular operating mode actually used. The waveforms can be wide pulse with frequency or phase code modulation for improved range resolution and clutter discrimination.
- **Duplexer:** this is an RF switch which conveys all the energy from the transmitter to the antenna in the transmitting phase while all the energy gathered by the antenna in the receiving phase is sent directly to the receiver chain. The rotary joint, not shown in the figure, allows the electric connection of the antenna to the remaining part of the radar notwithstanding the mechanical rotation of the antenna. Rotary joint with low loss and optical fibres for the transportation of signals are today available.

- **Receiver:** it provides frequency conversion, interference rejection and low noise amplification. The noise reduction is an important consideration in radar receiver design and is accomplished by the matched filter technique which maximises the SNR at the output. Signal down conversion in frequency is done in a number of steps up to base band where the signal is transformed in digital format via analogue-to-digital conversion (ADC) devices. Modern radar performs the ADC directly at intermediate frequency (IF); the advantage is to eliminate the unbalance between the I (in phase) and quadrature (Q) channels with corresponding advantages in terms of coherent rejection of clutter & jammer and integration of target echoes [23]. The trend today is towards a so called digital radar where the ADC is done very close to the antenna. Advantages of this approach are reported in [24].
- **Signal Processor:** this determines the presence or absence of targets while rejecting unwanted signals due to ground clutter, sea clutter, weather, radio-frequency interference, noise sources and intentional jammers. It is performed by coherent and/or not-coherent processing of time samples of received signals. The coherent processing acts on the I and Q components of signal collected during the time on target, while the non-coherent processing occurs after phase information is suppressed in the envelope detector. Detection is accomplished by comparing the processed video output with a threshold value, the crossing of the threshold being declared detection. The signal processor is implemented in real time special-processor hardware; more recently due to the extraordinary advances of the digital technology the processor makes extensive use of COTS (Commercial Off The Shelf) devices. Basic operations routinely implemented are: pulse compression, moving target indicator (MTI), pulse Doppler processing, moving target detector (MTD) (see Figure 2), CFAR (see Figures 3 and 4 for typical schemes) [1] and [25]. Also some modern phased-array radar have implemented in their signal processors the adaptive spatial filtering of jammers [23]. NCTR is another function that may be implemented in modern radar.
- **Data Extractor:** this provides the target measurements in range, angles (azimuth, elevation) (via moving window or monopulse), radial speed and possibly target signature for NCTR. In general, target may cause several detections in adjacent cells in range, Doppler and angles; the centroid (referred to as “plot” in the sequel) of the corresponding pattern of detections gives an estimate of the target measurement. The target extractor was implemented in a dedicated microcomputer; today COTS technology is used also here.
- **Data Processor:** it is essentially where the tracking filtering is implemented; see [26] and [27] for details.
- **User:** the output is generally a display to visualise the information contained in the radar echo signal in a form suitable for operator interpretation and action. There could be a link to convey data in a centre or in a computer for further processing. The visualised information on the display is called synthetic video. The plan position indicator (PPI), the usual display employed in radar, indicates the range and azimuth of a detected target. A modern radar display includes alphanumeric characters and symbols for directly conveying additional information; this is useful when target identity and altitude are to be displayed. Also the track is displayed with arrows and symbols.
- **Controller:** this decodes commands from the operator and sets up the operation modes, the appropriate system timing and the signal generator together with the processing functions on the received signals according to range, azimuth and elevation sectors. The controller also analyses signals for fault detection. It normally comprises a set of software programs implemented on a digital computer; used technologies are multiprocessor architectures based on COTS (Power PC and the like); programming languages can be Ada and C; real time operative system may be Lynx-OS or similar.

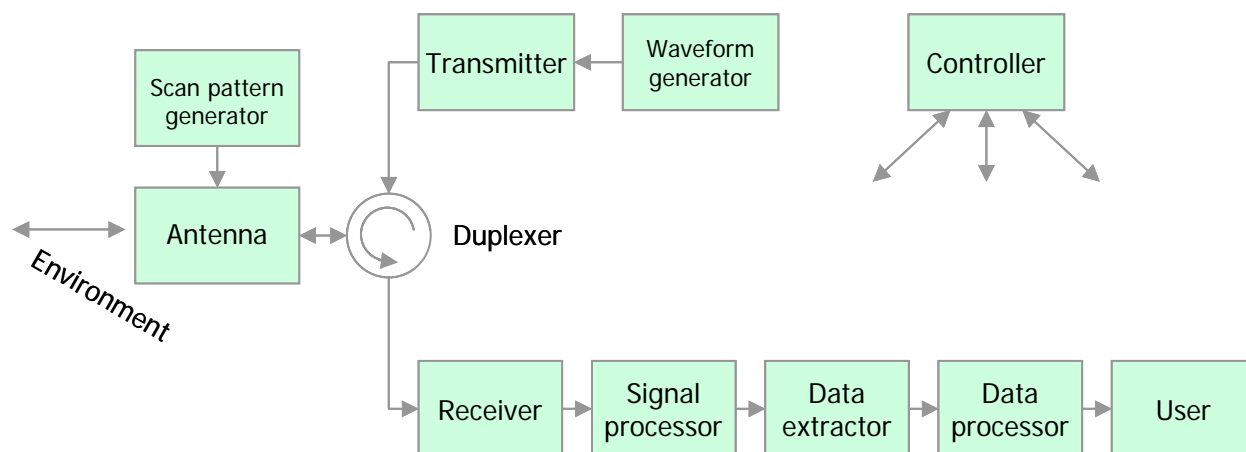

Figure 1: Simplified Scheme of a Modern Radar System (from A. Farina and F.A. Studer [26]).

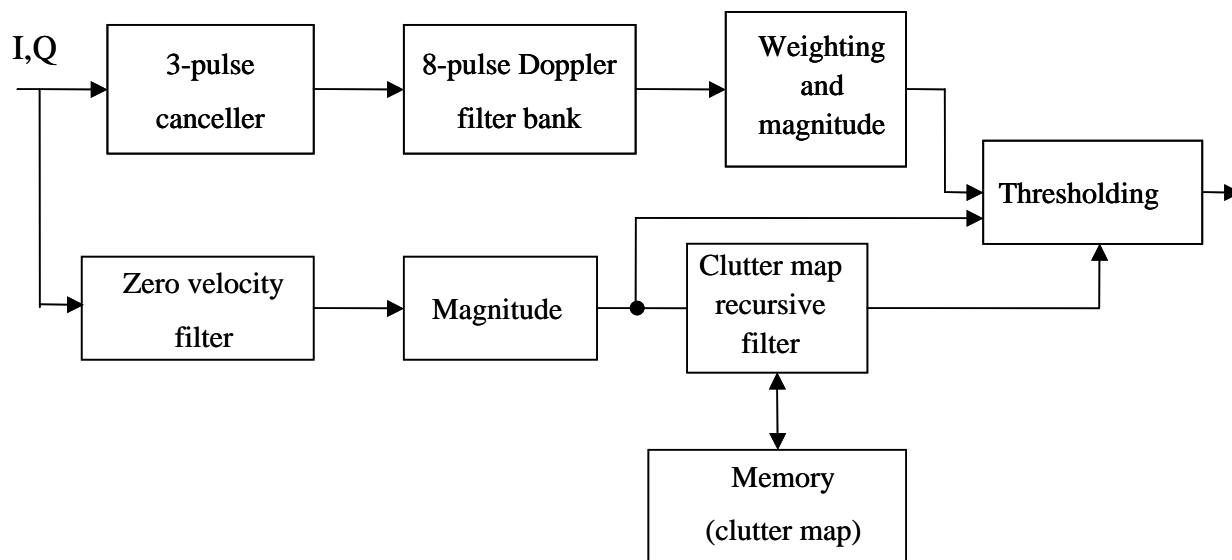

Figure 2: Block Diagram of the Original Moving Target Detector (MTD) Signal Processor.

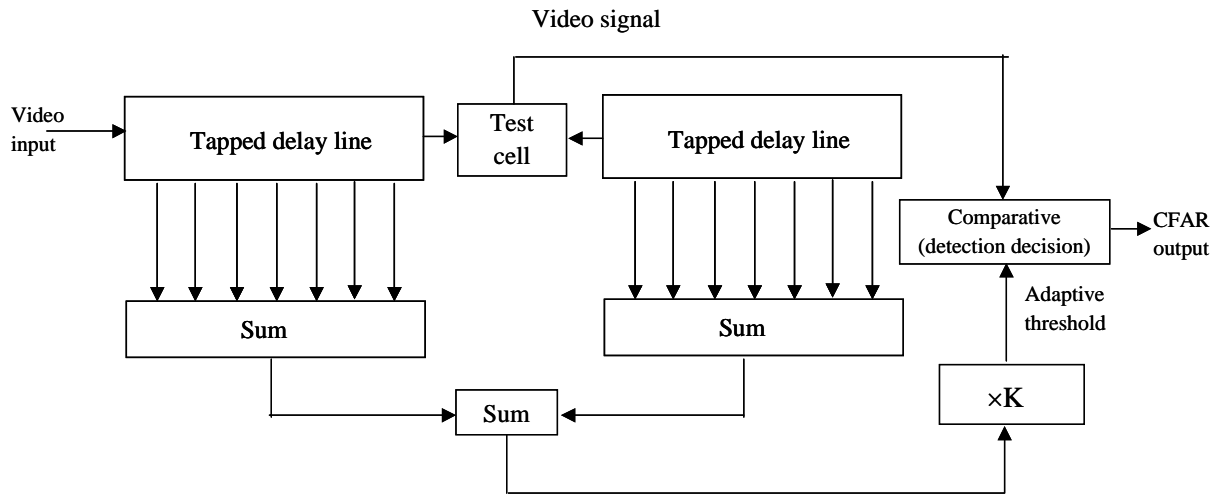

Figure 3: Cell Averaging CFAR.

Map-based CFAR working principle

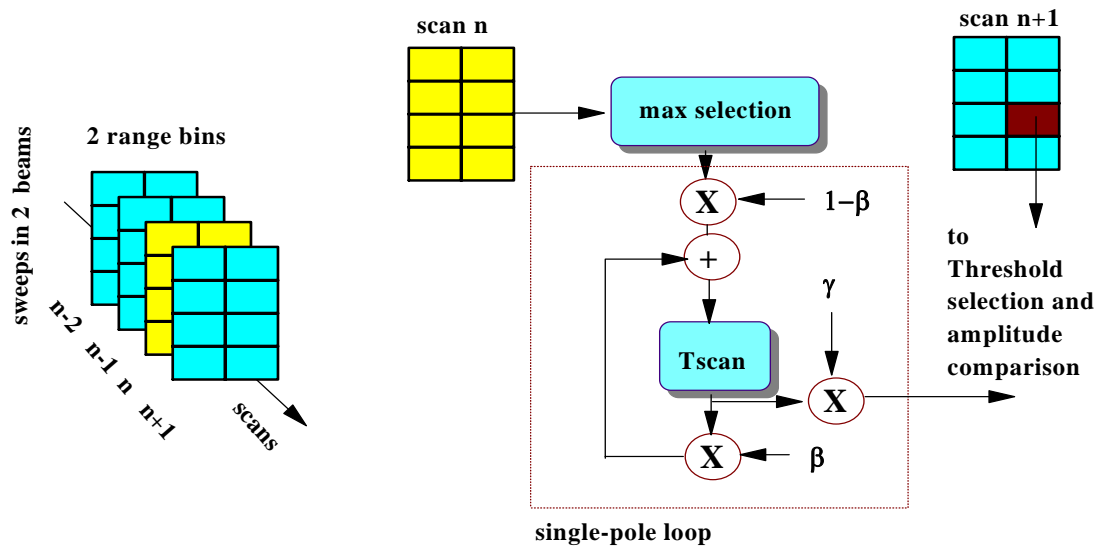

Figure 4: Map-Based CFAR (from A. Farina and F.A. Studer [35]).

4. PHASED-ARRAY RADAR SYSTEMS

Electronically steered phased-array antenna is composed of a number of individual radiating elements (such as dipoles and open-ended wave guides) suitably distributed on a certain surface. The planar array is the most used in radar applications, alternative configurations being the linear, conformal (non planar surface) and smart skin (especially for aircraft). One way of regarding the phased-array antenna is as the result of the spatial sampling of a conventional reflector antenna. The most distinctive feature is the control of the feed

signals to each radiating element. Control of the relative amplitude and phase of these signals allows the desired radiation pattern to be shaped and the beam to be rapidly steered in each direction of the controlled airspace without suffering the mechanical inertia of the classical rotating antenna. To cover 360° in azimuth there are two alternatives: four fixed planar arrays properly oriented or one rotating planar array [28]; back-to-back rotating antennas is also possible. The power generation and its distribution to the antenna elements can be realised by two methods:

- a) In the passive solution the power is generated by a single transmitting tube having generally a low duty cycle; the transmitting power is then shared among the different antenna elements by means of a distributing microwave network. In the reception phase the same network gathers the energy which is returned to the receiver.
- b) In the active array each antenna element – or group of elements (called sub-array) – is directly connected to a separate transmission amplifier, which can be a solid state device with high duty cycle, and to a separate amplifier for reception (see figure 5).

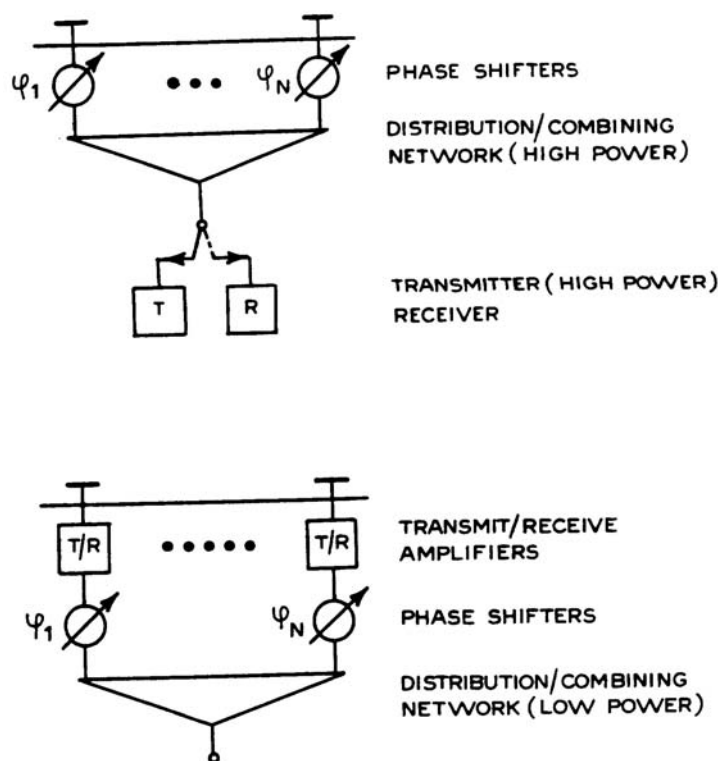

Figure 5: Passive and Active Phased-Array Antenna (from W. Wirth [28]).

The active solution is the most promising allowing transmission and reception losses to be reduced and signals with a high duty cycle to be generated; in fact, the solid state components have peak power limitation instead of the mean power limitation of traditional components. A further capability of the phased-array antenna is that of generating multiple beams. One application of this technique occurs in the three-dimensional phased-array antenna which forms multiple stacked beams in elevation to measure the target height. Another arrangement requires multiple beams only in the reception phase: multiple pulses are transmitted by a wide beam covering the whole controlled airspace region, but for the reception of echoes from all the directions,

simultaneous multiple narrow beams are needed. Also simultaneous multiple beams in transmission and reception are needed to speed up the search along a cluster of directions [69]. Another feature of the phased-array antenna is the controlled sidelobe level of the receiving pattern; this reduces the deleterious effect of clutter and directional interference; this can be achieved by generating nulls along the directions of the interferences [23]. The last interesting property to consider refers to reliability and maintenance. Redundancy is inherent in the array antenna due to the great number of identical antenna elements. The active array has in particular the graceful degradation feature. Indeed a failure of n amplifiers out of N connected to the antenna leads to a reduction of the SNR by only a factor of $(1-n/N)$. Furthermore the solid-state devices have a meantime between failure higher than that of vacuum tube. The major problem with active phased-array is the high cost mainly related to the design and production of the transmitter/receiver modules; figure 6 depicts a simplified scheme of it. Relevant references concerning phased-array radar are: [1], [23], [24], [28], [29] and [30].

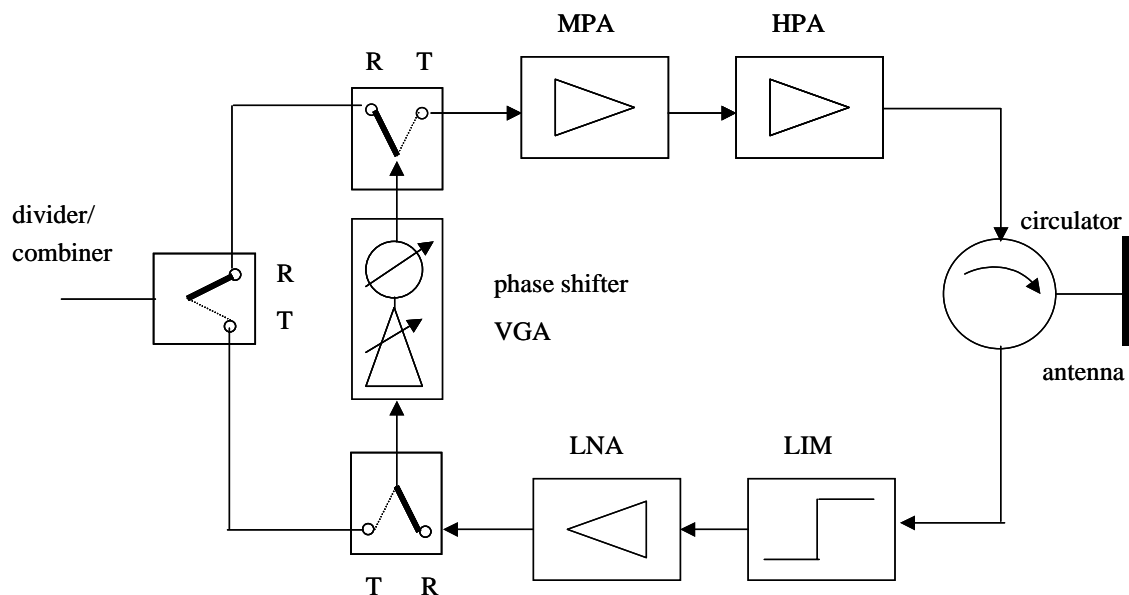

Figure 6: Block Diagram of Transmit/Receive Module (TRM). MPA: medium-power driver amplifier, HPA: High Power Amplifier, LNA: Low Noise Amplifier, LIM: Limiter, VGA: Variable Gain Amplifier (from W. Wirth [28]).

The flexibility in beam steering afforded by the electronic control makes the use of phased-array antennas attractive in radar applications. This is because of the possibility of using variable dwell-time (i.e.: time on target) and variable data rate. The dwell-time can be selected according to specific requirements, whereas mechanically scanning antennas process all targets in the same manner. The possibility of integrating a variable number of pulses, depending on target characteristics and on the environment, allows control of the detection probability – whatever the distance and the RCS of target are. Moreover, the probability of false alarms in the detection of a new target is strongly reduced by the possibility of a second look in those directions where verification is necessary (target confirmation). The variability of dwell-time is exploited to revisit different sectors of the surveillance volume with different rates; low elevation sector is revisited with high rate, while medium elevation and high elevation sectors are refreshed with lower rates. The capability of a phased-array to set the beam in any direction in a very short time allows tracking of many targets

simultaneously. The updating of tracks after their initiation is performed by steering the beam in those directions foreseen by the tracking algorithm. This method of processing radar data is different from the classical track while scan (TWS), where the tracking function is subordinate to the requirements of the search function; TWS is typical of a mechanically scanning radar. Moreover, flexibility in beam allocation allows variable processing of different types of targets. The targets can be grouped and tracks can be updated at a rate depending on a specific priority: this organisation allows optimum management of radar information.

In order to take advantage of the management of the beam steering, dwell time and emitted energy in a manner that is adaptive to the environment, it is necessary to have flexible signal and data processing units. Indeed, in contrast to a mechanically scanned radar, the filtering algorithms and the parameters of signal and data processing can be changed on-line, depending on the radar data previously processed. It is clear that the core of such a complex radar is the controller which performs appropriately matching of system resources to the dynamically evolving operational environment.

The working principle of the controller and the functions it performs in a phased-array radar is now briefly presented. The controller shown in figure 1 for a general monostatic radar becomes a key sub-system in the phased-array case. The main tasks performed by the controller are:

- i) Decision on which radar activities have to be accomplished in a certain time-frame;
- ii) Preparation of commands to the different radar units in order to execute the planned radar “looks”;
- iii) Gathering of the information on the status of the radar units (e.g.: digital words indicating the operational mode of the signal and data processors) for performance monitoring and fault detection; and
- iv) Interface with the human operator.

The controller, comprising a set of programs, is usually implemented in a general purpose computer which interfaces with the radar hardware (signal processor, wave form generator, beam steering computer, etc.) and the other external devices such as keyboard and display. Because of the different speeds of operation, the computer interfaces with the surrounding devices by means of buffers and data buses.

The algorithms of the controller are now briefly considered. Each radar activity (e.g.: search, target confirmation, track initiation and track maintenance) requiring radar and computer resources is tagged with a priority index. The radar resources are the time (dwell time in a certain direction) and the transmitted energy, while the computer resources are the processing time and the memory. Scheduling of the radar activities is made according to their priority; in this way, saturation of radar and computer should be avoided. In other words, the radar activities are scheduled in such a way that the demand on radar and computer resources does not exceed the capabilities of the two systems. Every time a high-priority task is requested, the controller puts aside the partially completed low-priority activity which is resumed when time permits. In the event of saturation arising due to a large number of requests, the controller allows a graceful degradation mode of operation by cancelling the low-priority requests. Operation of the controller in a phased-array can be understood by considering figure 7 showing the functional interaction of the controller, the radar hardware, the data processor and the external peripherals. In the radar controller, the following three subsystems can be recognised: the manager, the scheduler, the real-time controller. The manager receives requests for radar activities (e.g. search, tracking) from the keyboard according to a specific mode of working or operator requirements. Based on the importance of the requests, the manager generates a prioritised list in order to be executed by the radar. This list is passed to the scheduler which should complete all the requests within a prescribed time period. Taking account of the limited resources of radar and computer, the scheduler

establishes a specific time table of radar events. From this time table, it constructs a list of commands for the radar hardware which are distributed to the radar units by the real-time controller. The results of radar actions are detections which are used to generate clutter and jammer maps and to yield the co-ordinates of the useful targets. These detections are stored in a buffer and used to modify the specified normal mode of radar by sending requests for new radar activities to the controller through the bus which closes the control loop linking the controller, the radar hardware and the data processor. Examples of requests for new radar activities are *search mode in clutter* for the directions in the controlled airspace which pertains to the clutter map, *target-confirmation* and *track-initiation* modes for the useful target detections, and track updates for the established tracks. The contents of the detection and track buffers are periodically shown on the display.

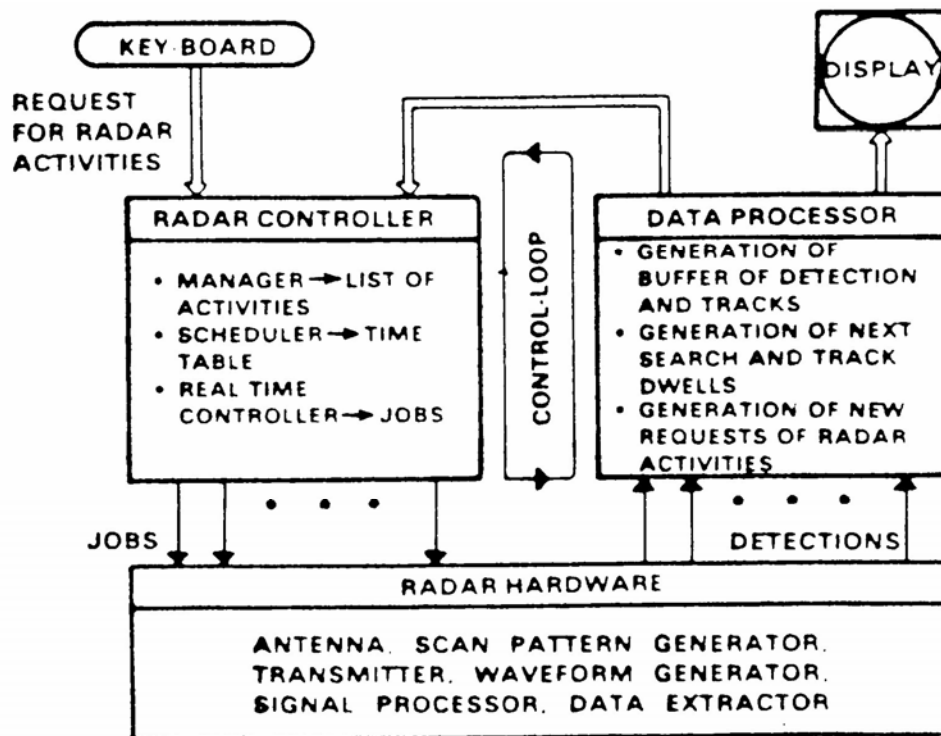

Figure 7: The Managing Computer in a Modern Phased Array Radar (from A. Farina and F.A. Studer [26]).

One of the lecture of the series will study the use of KBS technology in phased-array radar systems.

5. SIGNAL PROCESSING

Radar signal processing can be defined as the manipulation of the received signal, represented in digital format, to extract the desired information whilst rejecting unwanted signals. In particular, a surveillance radar takes a decision about the presence or absence of targets whilst cancelling radar echoes caused by ground clutter, radio frequency interference and noise source. An airborne radar accomplishes the same job in spite of the strong clutter return and its Doppler spread caused by the platform motion. A tracking radar, in addition to detection, is concerned with an accurate estimation of the target kinematics parameters (resort is made to maximum likelihood estimation procedure and its sub-optimum implementations). The list could be extended

to other radar systems as the low probability of intercept, the synthetic aperture radar, the space-based radar and the multistatic radar. Whatever the radar system, the basic operations performed by the signal and data processors are as follows: detection of presence of targets, if any; extraction of information from the received waveform to determine a wealth of relevant parameters of the targets (such as position, velocity, shape, and electromagnetic signature). The first step of the design can be recognised in the formulation of mathematical models more adherent to the real environment in which the radar operates. Several major areas of research and development can be singled out in connection with radar detection: theory of optimum detection, adaptive detection theory, detection of signals having non-Gaussian probability density function (pdf), multidimensional processing and super resolution algorithms. Some of these are extensively described in the literature; see for instance, [23], [25]. Some techniques have been successfully implemented in real radar systems.

5.1 MTI, MTD, Pulse-Doppler

MTI, MTD (figure 2) and pulse Doppler radar concepts are successful processing schemes to reject clutter echoes and detect targets. An extensive literature describes these techniques; see for instance, [1], [63] and [32]. Recent research has focussed on an accurate statistical modelling of clutter echoes. A remarkable result is the collection and processing of recorded live data from vegetated ground clutter organised by MIT-LL: probably the most extensive collection of ground clutter data ever done; the details are reported in the recent book [31]. Some of these data have been processed with modern processing algorithms, the achieved results being described in [33]. Furthermore, under certain conditions (radar operating at low grazing angle and/or with high resolution) the clutter echoes could be described as having a non Gaussian pdf; the exploitation of multidimensional coherent non Gaussian pdf brings to new processing schemes: see [34] and [64] for details.

5.2 CFAR (Constant False Alarm Rate)

Clutter and/or hostile noise jamming can be much larger than receiver internal noise. As a consequence the detection threshold can be exceeded and many false alarms can occur; an automatic detection and tracking system can be overloaded. CFAR automatically raises the threshold level thus avoiding the overload of the automatic tracker with extraneous information [1]. CFAR is achieved at the expense of a lower probability of detection of desired targets. Cell averaging – CA CFAR (Figure 3) – is due to Finn and Johnson; it is the optimum when the statistic of the envelope is Rayleigh. It uses an adaptive threshold whose level is determined by the clutter and/or noise in the vicinity of the radar echo. Two tapped delay-lines sample echo signals from the environment in a number N of reference cells located on both sides of the cell under test (CUT). The spacing between reference cells is equal to the radar range resolution (usually the pulse width) [1]. The CUT signal is compared to the adaptive threshold derived from the sum of the outputs of the tapped delay lines defining the reference cells. It changes as the radar environment changes and as the received pulse travels out in time. When multiplied by a constant K , the sum provides an adaptive threshold to maintain a CFAR. Thus the threshold can adapt to the environment as the pulse travels in time [1]. The greater the number of reference cells in the CA-CFAR the better is the estimate of the background clutter or noise and the less will be the loss in target detectability. There is a limit, however, to the number of reference cells that can be used in practice since the clutter must be relatively homogeneous over the reference cells. A typical CFAR design for an aircraft-surveillance radar might have a total of 20 reference cells that sample the environment a half-mile to either side of the signal in the CUT [1]. In a pulse Doppler radar, the reference cells can be taken from adjacent Doppler filters as well as from adjacent range cells. It can be shown that the CA-CFAR is embedded in the so called adaptive matched filter, one of the most modern and powerful adaptive processing schemes [65].

Limitations of CA-CFAR

- a) False alarms can result when the leading or trailing edges of a clutter patch move along the reference cells. This deleterious effect can be mitigated by summing the leading and lagging reference cells separately and using the greater of the two to determine the threshold; this is the greater of (GO) CFAR; it introduces however an additional CFAR loss of 0.1-0.3 dB [1].
- b) One or more targets within the reference cells along with a primary target in the CUT raise the threshold, thus the detection of the primary target in the CUT might be lost. One method for reducing the effect of multiple targets is to censor (remove) the outputs of those reference cells that are much larger than the rest. A predetermined number J of reference cells (those with the largest returns) are removed and the adaptive threshold is determined by the remaining $(N-J)$ cells; this is the censored mean-level detector. Loss associated with this CFAR may be in the order of 1 dB. Another approach to handling multiple nearby targets is the ordered statistic (OS) CFAR; the threshold is determined from one single value selected from the OS. The output from the N reference cells are put in order from smallest to largest, and the K -th ordered value when multiplied by a scalar is the threshold [1].
- c) The usual CFAR considerably reduces the range resolution so that two equal-amplitude targets can be resolved only if they are spaced greater than 2.5 pulse widths [1]. One reason for the poor resolution is that the range cells adjacent to the CUT are not used as part of reference cells since the target energy in the sidelobes would affect the threshold.
- d) In many cases the form of clutter pdf is not known; in general it is different to the Rayleigh hypothesised in the CA-CFAR. A non parametric or distribution free detector has also been considered for CFAR; it has relatively large loss [1].

A clutter map (figure 4) divides the radar coverage area into cells on a polar or a rectangular grids. The clutter echo stored in each cell of the map can be used to establish a threshold for that range and azimuth. A number proportional to the amplitude of the clutter within the cell is stored at each cell of the clutter map. Since the clutter can change with time, the value of the clutter in each cell is continuously updated by resorting to a recursive loop with a prescribed forgetting memory factor [1], [35]. The larger the number of scans the more accurate will be the estimate of the clutter and the lower the loss (in the order of 0.8dB for averaging time of approximately 2 minutes [1]). On the other hand, the averaging time should be shorter than the limited dwell-time in which moving clutter (rain or chaff) is within the cell. A short averaging time also allows the threshold to recover to its improper state within a few scans after a target has passed through the cell. Self-masking and mutual masking problems are analysed in details in [35]. The response of the clutter map CFAR might be affected when a target of slow speed remains within the cell long enough to modify the threshold. This effect can be reduced by making the map cell greater than the radar resolution cell [35]. The increase of the size of the clutter-map cell should not be excessive since it reduces the interclutter visibility [35]. A clutter map CFAR has an advantage over the CA-CFAR in that it is not affected by non homogeneous clutter (edge effects) [1]. Another attribute of the clutter map is the potential to suppress slowly moving objects such as birds. Each threshold setting is checked against a clutter map before initiating a track. This technique is also referred to as scan-to-scan correlator [26, pp. 139-143].

One of the lecture series will study the use of KBS technology to CFAR.

5.3 Adaptivity

Adaptive signal processing applies to three different types of radars, namely:

- i) Ground based or ship-borne radars for clutter cancellation;
- ii) Ground based or ship-borne radars equipped with a multi-channel phased-array antenna for jamming cancellation; and
- iii) Airborne early warning (AEW) radar equipped with a multi-channel phased-array antenna for clutter and jammer cancellation.

In all three cases the received radar echoes are converted to a digital format and the adaptive signal processing performed with digital technology. Common to the three applications is the type of adaptive processing: it takes an appropriate linear combination (assumption is made that radar echoes have Gaussian pdf) of signals received by the radar. The filter output is envelope-detected and compared against a suitable detection threshold set so as to maximize the detection probability (P_d) and to obtain a prescribed probability of false alarm (P_{fa}). Let N be the number of degrees of freedom used in adaptive processing, i.e. the dimension of the vector collecting the snapshot of radar data at a certain sampling instant. In the application area i., N is the number of echoes (T seconds apart, where T is the radar pulse repetition time (PRT)) captured by the radar receiving channel commensurate with a train of N coherent pulses transmitted by the radar. The clutter interference is cancelled by an adaptive filter, operating in the Doppler frequency domain, which obscures the Doppler frequency interval occupied by the clutter spectrum. The filter sets a peak at the Doppler frequency which is expected from the useful target to be detected (for details see part I of [25]). In the application area ii., N is the number of sub-arrays (in which the radar antenna is decomposed) and associated receiving channels. The directional jamming/radio frequency interferences are cancelled by adaptively shaping the received antenna pattern to get deep nulls in the directions of arrival of interferences (for details see [23] and [40]). In the application area iii., N is the product of the number of received radar echoes, T seconds apart, and the number of sub-arrays in which the array aperture is decomposed. Both the clutter and jammer directional interferences are cancelled by synthesizing a two-dimensional filter that operates in the domains of Doppler frequency and direction of arrival. This type of filtering is also referred to as space-time adaptive processing (STAP); for details see [37] and the next subsection 5.4. The common problem of all the three applications is the online calculation of the weights to be used in the linear combination for the derivation of the adapted filter output. While the desired signal can be assumed to be known a priori, the interference is not known and is changing with time and in space; this means that the interference characteristics (represented by a covariance matrix) have to be estimated on line. A numerically robust and computationally efficient procedure to compute the adaptive filter output is known as QR-decomposition (QR); for details see, for instance, [23], [38] and [39]. A further advantage of the QR method is that it has a high degree of inherent parallelism which can be exploited to speed up the computations which are necessary in the applications considered here. Typical values of the computational requirements are as follows. For the first two application areas N is 10 to 20, the sampling rate is in the order of MHz and the number of operations amounts from Mflops to few Gflops. In application area iii., N is between 50 and 100 and even more, the sampling rate is in the order of MHz and the number of operations is 10 Gflops up. To reduce the considerable computational load especially required for application area iii., the following computational strategy can be devised. Extract the adapted weights at a rate lower (say, an order of magnitude) than the input data rate and apply them to the radar snapshots at their natural rate. This strategy is applicable only if the interferences change not too fast in time and space. An efficient algorithmic procedure to extract the weights is named Inverse QR (IQR) (see [66] for details).

A further point to address is the need to simultaneously focus more than one search beam (either one-dimensional, in Doppler frequency or direction of arrival, or two-dimensional in Doppler frequency and direction of arrival) to speed up the search within a prescribed sector or volume. The minimum variance distortion less response (MVDR) algorithm gives the technical mean to solve this operational problem

(see [66] for details) in contrast to the generalized sidelobe canceller (GSLC) approach that focuses one search beam at a time [23]. The implementation of adaptive beam forming algorithms turns out to be a challenging computational problem due to the high data rate requested and to the ill conditioning of the interference covariance matrix in typical radar scenarios. Not surprisingly, the problem motivated the development of systolic algorithms and the investigation of mapping strategies on different parallel computing architectures; remarkable is the MUSE (Matrix Update Systolic Experiment), described in [67], for adaptive nulling with 64 degrees of freedom (DoF).

5.4 Space-Time Adaptive Processing (STAP)

The detection of low flying aircrafts and/or surface moving targets, and the stand-off surveillance of areas of interest require a radar on an elevated platform like an aircraft. The AEW (Airborne Early Warning) radars pose a number of interesting technical problems especially in the signal processing area. The issue is not new: detect target echoes in an environment crowded of natural (clutter), intentional (jammer), and other unintentional radio frequency (especially in the low region of microwaves, e.g. VHF/UHF bands) interference. The challenge is related to the large dynamic range of the received signals, the non-homogeneous and non-stationary nature of the interference, and the need to fulfill the surveillance and detection functions in real time. One technique proposed today to solve the problem is based on STAP [36] to [39], [41] and [66]. Essentially, the radar is required to have an array (for instance, a linear array along the aircraft axis) of N antennas each receiving M echoes from a transmitted train of M coherent pulses. Under the hypothesis of disturbance having a Gaussian pdf and a Swerling target model, the optimum processor is provided by the linear combination of the NM echoes with weights $\mathbf{w}=\mathbf{M}^{-1}\mathbf{s}^*$, envelope detection and comparison with threshold. \mathbf{M} is the space-time interference covariance matrix, i.e. $\mathbf{M}=\mathbf{E}\{\mathbf{z}^*\mathbf{z}^T\}$ where \mathbf{z} (dimension $NM \times 1$) is the collection of the NM disturbance echoes in a range cell, \mathbf{s} – the space-time steering vector – is the collection of the NM samples expected by the target, and $(*)$ stands for complex conjugate (see Figure 8). This linear combination permits a two-dimensional filtering of clutter echoes that is more efficient than the one-dimensional filters in Doppler and angle respectively; this is shown in the well known Figure 9 (see also the paper by Klemm in [39, pp.2-1, 2-24]). A side-looking sensor configuration is assumed. The clutter spectrum extends along the diagonal of the $(\cos \Phi - f_D)$ plot. Note the modulation by the transmit beam. Conventional temporal processing means that the projection of the clutter spectrum onto the f_D axis is cancelled via an inverse filter. Such filter is depicted in the back of the plot. As can be seen the clutter notch is determined by the projected clutter mainlobe which is a Doppler response of the transmit beam. Slow targets are attenuated. Spatial processing used for jammer nulling requires that the clutter spectrum is projected onto the $(\cos \Phi)$ axis. Applying an inverse spatial clutter filter, however, forms a broad stop band in the look direction so that the radar becomes blind. Both fast and slow targets fall onto the clutter notch. Space-time processing exploits the fact that the clutter spectrum is basically a narrow ridge. A space-time clutter filter, therefore, has a two-dimensional narrow clutter notch so that even slow targets fall into the pass band.

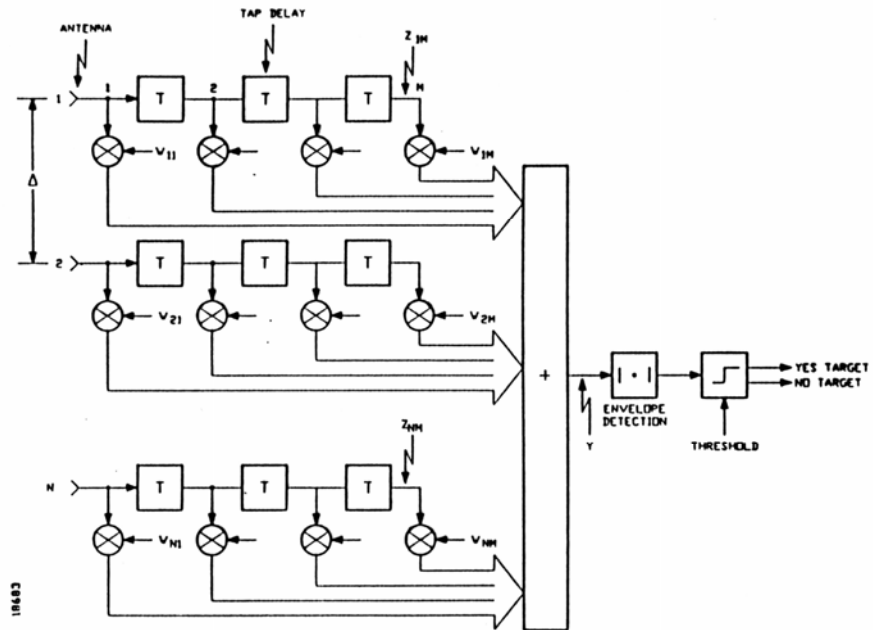

Figure 8: Scheme for STAP.

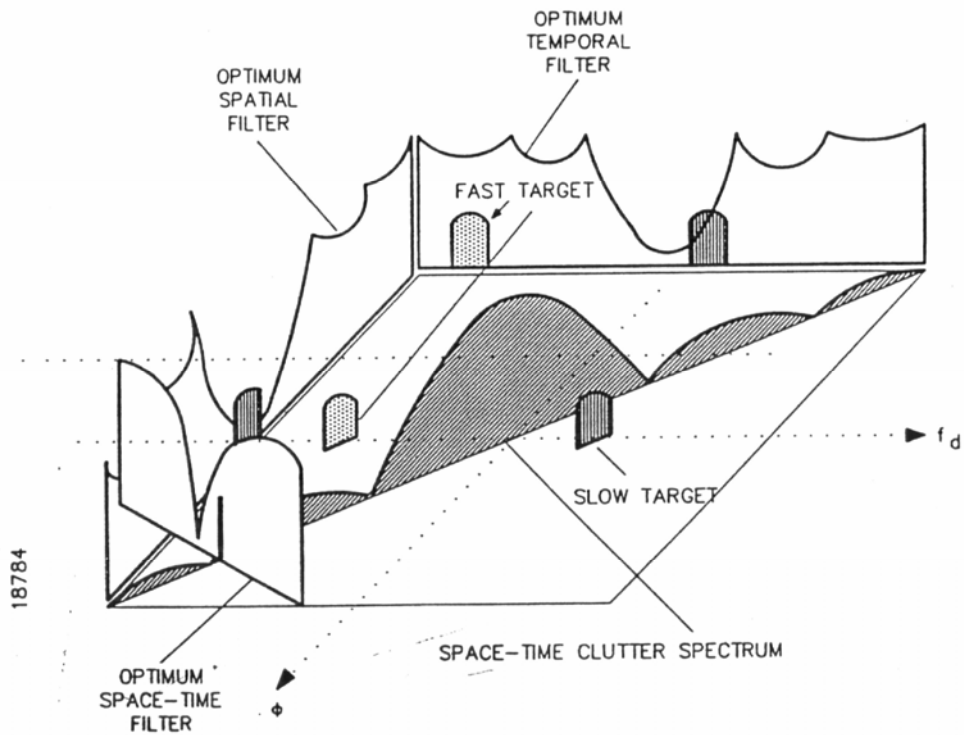

Figure 9: Scheme for STAP (from J. Ender and R. Klemm [37]).

A direct implementation, (via Sample Matrix Inversion, SMI) of the weight equation $\mathbf{w}=\mathbf{M}^{-1}\mathbf{s}^*$ is not recommended. One reason is related to the poor numerical stability in the inversion of the interference covariance matrix especially when large dynamic range signal is expected during the operation; another one is the very high computational cost. There is a need of extremely high arithmetic precision during digital calculation. Note that double precision costs four times as much as single precision. The situation would be different if, instead of operating on the covariance matrix \mathbf{M} , we would operate directly on the data snapshots $\mathbf{z}(k)$, $k=1,2,\dots,n$, where n is the number of snapshots (i.e. : range cells) used to estimate the weights \mathbf{w} . It can be shown that the required number of bits to calculate the weights, within a certain accuracy, by inversion of \mathbf{M} is two times the number of bits to calculate the weights operating directly on the data snapshots $\mathbf{z}(k)$. This is so because the calculation of power values is avoided thus the required dynamic is halved. The algorithms that operate directly on the data are referred to as “data domain algorithms” in contrast to the “power domain algorithms” requiring the estimation of \mathbf{M} . Figure 10 depicts both approaches. References [66] and [68] explain the details of power and data domain algorithms; an example of their application to recorded live data is in [41].

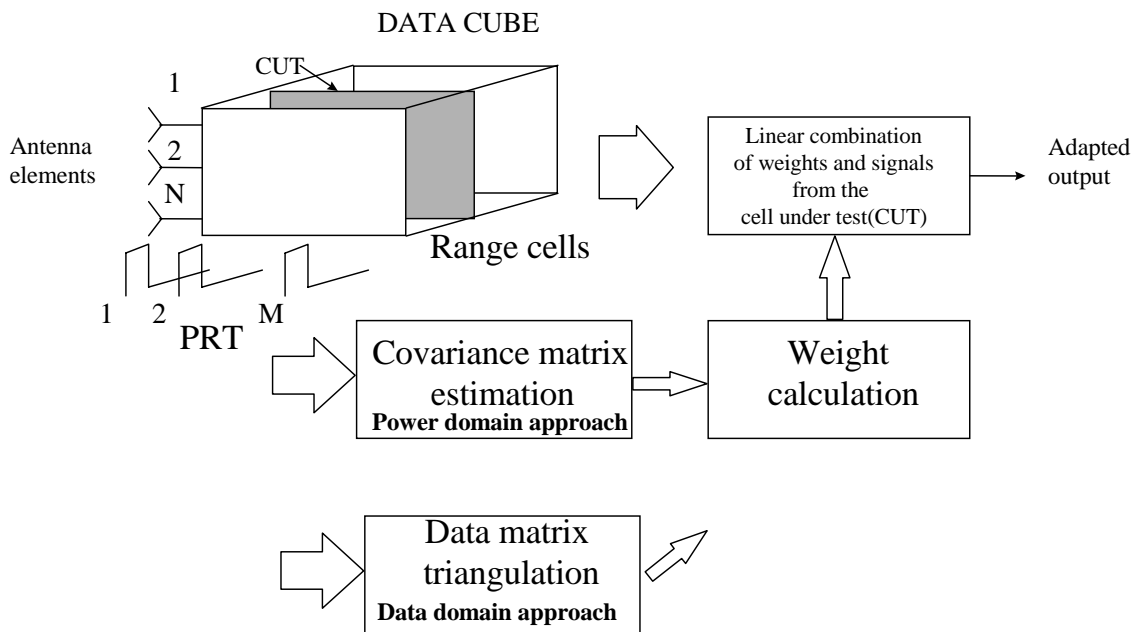

Figure 10: The Power and Data Domain Approaches for STAP.

Much attention today is put on the so-called reduced-dimension (RD) STAP with the intent to limit the computational burden and the number of secondary data for adaptivity. Figure 11 is an overview of RD-STAP methods. The processor can transform the space-time data via the *data independent* transformation matrix \mathbf{T} with size $PQ \ll NM$. Common transformations include beam forming and Doppler processing steps. Examples of RD-STAP techniques are reported in the paper by B. Melvin [39, pp. 1-1, 1-19]. The Factored Time-Space (FTS) algorithm is a post-Doppler method suitable for long coherent dwells and high radial velocity targets. The FTS method essentially involves spatial notching of the clutter in a given Doppler filter. Since FTS provides no temporal adaptivity, it is not a true STAP algorithm. To enhance performance with only modest increase in required sample support and computational burden, DiPietro proposed the Extended Factored

Algorithm (EFA). The EFA method involves adaptively combining several adjacent Doppler filters (typically three) and all spatial channels. The EFA method often exhibits performance very close to the theoretical joint-domain space-time bound. To provide diversity in spatial and temporal DoF, Wang and Cai developed the Joint Domain Localized (JDL) technique which is a post-Doppler, beam space method. Basically, the processor forms multiple beams, then Doppler processes each beam, and finally selects a collection of adjacent angle-Doppler bins over which to adapt the filter response. JDL provides good performance with very low training data requirements and very modest computational burden (see also A. Farina et al. paper in [38]). Three adjacent beams by three adjacent Doppler bins is a typical localized JDL processing regions.

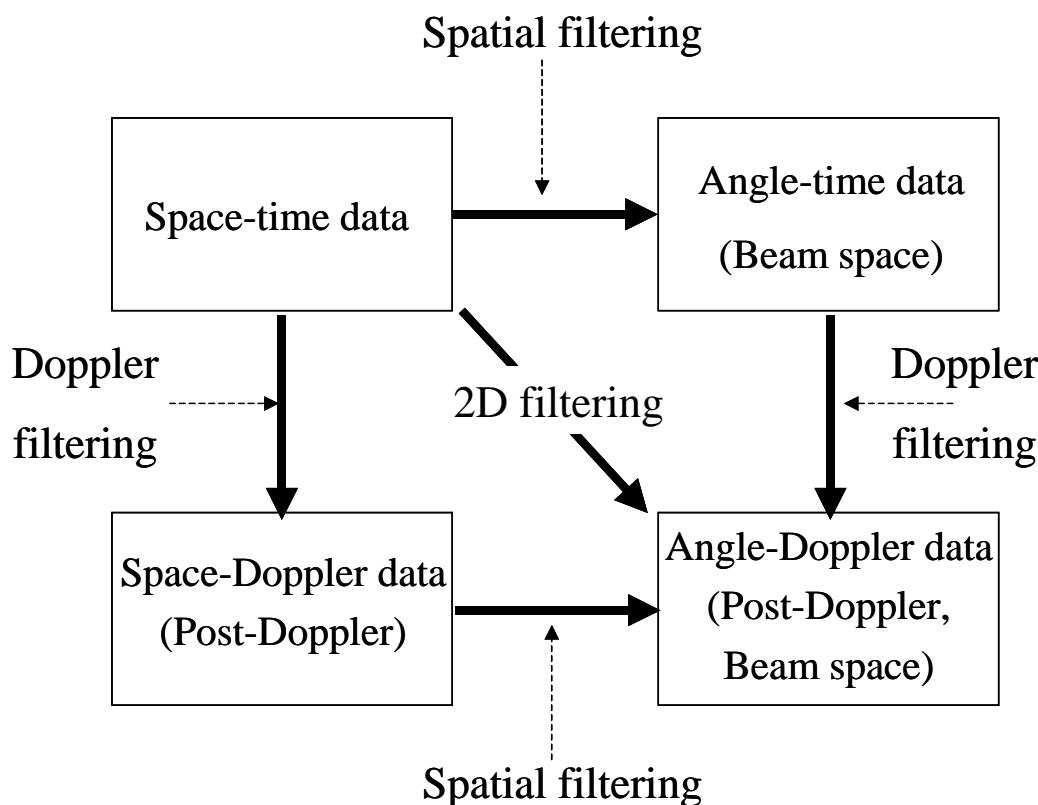

Figure 11: Overview of Reduced-Dimension STAP Methods (from J. Ward [36]).

Reduced-rank STAP methods involve *data-dependent* transformation and selection; details are reported in B. Melvin paper [39, pp. 1-1, 1-19]. The principal components is one of such methods. A benefit of this approach is a reduction in training data support; however, computational burden remains high, since the processor must compute eigenvalues and eigenvectors of the interference covariance matrix.

From a practical point of view, the first (non-adaptive) DPCA (Displaced Phase Center Antenna) experiment involving an array antenna has been carried out by Tsandoulas late '50s. More recent experiments conducted in USA adopt linear side-looking arrays (NRL-AAFTE and MCARM). The Mountaintop program, also in USA, started in 1990 to study advanced processing techniques and technologies to support the requirements of future airborne early warning radar platforms; in particular the effect of terrain scattered jamming has been studied. In Europe the AER II program (Germany), the DO-SAR experiment (Germany) and the DERA

experiment (UK) have been conducted. Today there are three operational systems with space-time ground clutter rejection capability: Joint STARS, AN/APG-76, and the AN/APY-6. The first one has a 3-aperture side-looking array antenna. The AN/APG-76 is a forward looking nose radar and the AN/APY-6 has both side-looking and forward looking capability. From the literature it is not clear whether these systems are based on adaptive algorithms (STAP) or use some non-adaptive DPCA-like techniques. References to these systems can also be found in R. Klemm paper in [39, pp.2-1, 2-24].

6. DATA PROCESSING

6.1 Tracking

The tracking filter processes the target radar measurements (e.g.: range, azimuth, elevation and range rate) in order to achieve the following purposes: reduce the measurement errors by means of a suitable time average, estimate the velocity and acceleration of the target, predict future target position. The tracking filter can be considered as an application of stochastic filtering theory which is an important branch of modern theory of dynamic systems. The latter is characterised by the introduction of the following concepts: dynamic evolution of the system state variables, optimal control under well-defined disturbances and inputs, use of stochastic processes to model noise-corrupted data and uncertain parameters. The concept of a dynamic system is introduced to obtain a mathematical description of the input-output behaviour of a physical object of interest; for instance, the time evolution of the position of an aircraft. Deterministic system theory is not completely sufficient for practical design of operational systems. First, no mathematical model of a system is ever perfect; approximations, uncertain parameters, unmodelled effects are inherent ingredients. Secondly, dynamic systems are driven not only by input commands but also by disturbances from the environment and imperfections in the actuator's ability to deliver commanded controls. These are uncontrollable effects for which there are usually no adequate deterministic models. Finally, sensors that provide data about the system may deliver only partial information about the system state; they introduce their own time lag and other dynamics and are always noise-corrupted. These considerations justify the extension of the dynamic system concepts to the stochastic case where the aforementioned uncertainties and approximations are modelled as randomised input processes. A fundamental problem then arises in that it is necessary to find a method to optimally estimate the dynamic state on the basis of such stochastic mathematical models and incomplete noise-corrupted data from sensors. The solution is given by the optimal filtering theory. Important break troughs in this theory have been the Wiener filtering for stationary processes and the Kalman-Bucy filter (KF) which represents the optimal filter when both the dynamic state and the measurement equations are linear and the forcing and measurement noises are independent and have a Gaussian pdf. Practical implementation of the KF to tracking a flying object has required the following modifications and upgrades: include some form of adaptivity to account for unpredictable target manoeuvres; introduce more complex target models such as a bank of multiple models (MM) to which corresponds the MM and interactive MM (IMM) tracking filters; include a plot-track pairing logic which, in the case of a multi-target scenario, brings to an exponential explosion of the computational complexity if the optimum approach is invoked; successfully implement the multiple hypotheses tracking (MHT) to tackle the plot-track pairing logic at reasonable computational cost; account for the problem of non linearity (e.g.: tracking of ballistic re-entry targets) with some approximated form of non linear filtering (mainly the so-called extended KF); fusion techniques to manage and combine data provided by more than one sensors that look at the same surveillance space.

Text books and monographs are today available that discuss in details the tracking problems; some of them are: [26], [27], [42] to [46] just to mention a few. Recently the need to perform more accurate estimates in non linear, non Gaussian environment has prompted the conception of new approximations of the optimum

filtering that effectively go beyond the KF theory. There are two approaches that have progressively acquired the favour of scientist, engineers and practitioners, they are the Unscented KF [47], [48] and the Particle Filtering [49] to [51].

One lecture of the series will study the use of KBS technology in the tracking systems.

7. CONCLUSIONS

This paper is an introduction to the lecture series on the application of KBS to radar signal and data processing. A wide review of the radar system techniques has been provided to facilitate the explanation of the application of KBS to radar that will follow in the next papers of this lecture series. KBS application to radar systems has been envisioned mainly by scientists of Rome Lab (USA) in cooperation with their Colleagues from university and industry; a list of relevant publications on the subjects are: [52] to [62].

8. ACKNOWLEDGEMENTS

This review paper has greatly benefited from papers and books duly referenced in the next section and in the text.

9. REFERENCES

- [1] M.I. Skolnik, “*Introduction to radar systems*”, 3rd ed., McGraw Hill, pp. 14-19, 2001.
- [2] V.S. Chernyak, “*Fundamentals of multisite radar systems*”, Gordon and Breach Science Publishers, 1998.
- [3] Various Authors – “L’insegnamento e l’opera di Ugo TIBERIO” (in Italian). Booklet edited by the Italian Navy Staff for the celebration of : “L’insegnamento e l’opera di Ugo Tiberio 50 anni dopo la pubblicazione del primo lavoro sui Proceedings of the IRE “ – Campobasso 24 ottobre 1998. Annex to the ‘ Notiziario della Marina Italiana’, Nr. 10 - October 1998.
- [4] M.I. Skolnik, “Fifty years of radar”, *PIEEE*, vol. 73, Feb. 1985, pp. 182-197
- [5] *IEEE Aerospace and Electronic Systems Magazine*, October 2000, no. 10, Jubilee issue, p. 119.
- [6] D. Ausherman, A Kozma, J. Walker, H. Jones, E. Poggio, “Developments in radar imaging”. *IEEE Trans on Aerospace and Electronic Systems*, July 1984, pp. 363-400.
- [7] L.J. Cantafio (editor), “*Space-based radar handbook*”, Artech House, Inc., Norwood, Ma, 1989.
- [8] I.S. Reed, “A brief history of adaptive arrays”, Sudbury/Wayland Lecture Series, (Raytheon Div. Education) Notes, 23 October 1985.
- [9] *IEEE AESS 1991 Pioneer Award* to F.R. Dickey, F.M. Staudaher, M. Labitt, *IEEE Aerospace and Electronic System Magazine*, May 1991, vol. 32, p. 32.
- [10] M.I. Skolnik, “Opportunities in radar-2002”, *Electronic, Communication and Engineering Journal (ECEJ)*, IEE, December 2002, pp. 263-272.

- [11] “Radar development at Lincoln Laboratory: a fifty-year review”, MIT-Lincoln Laboratory Journal, vol. 12, no. 2, 2000, pp. 139-444.
- [12] M.I. Skolnik, “*Radar handbook*”, 2nd ed., McGraw-Hill, 1990.
- [13] D.K. Barton, “*Modern radar system analysis*”, Artech House, Norwood, MA, 1988.
- [14] F.E. Nathanson, “*Radar design principles*”, 2nd ed., McGraw Hill, New York, 1991.
- [15] E. Brookner (Ed.), “*Aspects of modern radars*”, Artech House, Norwood, MA, 1988.
- [16] IEEE Standard (521TM) Letter Designations for Radar-Frequency Bands Sponsored by Letter Band Standard Committee of the IEEE Aerospace and Electronic Systems Society (2002) for the IEEE Standards Activity Department, Piscataway, NJ, USA, 8th January 2003.
- [17] R.J. Galejs, “Volume surveillance radar frequency selection”, Proc. of IEEE Int. Radar Conference, Alexandria (Va), May 7-12, 2000, pp. 187-192.
- [18] W.J. Fontana, R. H. Krueger, “An/SPY-3: the Navy’s next generation force protection radar system”, Naval Surface Warfare Center, Dahlgreen Division Technology Digest, 2000-2001 Issue: Theater Air Defense, pp. 230-239.
- [19] E. Hanle, A. Farina, C. Pell, “Bistatic / Multistatic radar bibliography”. Special issue on bistatic and multistatic radar, IEE Communications, Radar and Signal Processing, Pt. F. vol. 133, no. 7, December 1986, pp. 664-668.
- [20] N.J. Willis, “*Bistatic Radar*”, TSC, Silver Spring, MD, 1995, 2nd Edition.
- [21] P.E. Howland, “Target tracking using television-based bistatic radar”, IEE Proc. Radar, Sonar and Navigation, June 1999, vol. 146, no. 3, pp. 166-174.
- [22] E. Hanle, “Radar and general radiolocation. Glossary of terms and definition in English, French and German”, VDE, Verlag, 2002.
- [23] A. Farina, “*Antenna based signal processing techniques for radar systems*”, Artech House, 1992.
- [24] R.A. Stapleton, S.R. Horman, H.H. Szu, “DAR technology for volume surveillance radar application”, Naval Surface Warfare Center, Dahlgreen Division Technology Digest, 2000-2001 Issue: Theater Air Defense, pp. 240-249.
- [25] A. Farina (Editor), “*Optimized radar processors*”. On behalf of IEE, Peter Peregrinus Ltd. London, October 1987.
- [26] A. Farina, F.A. Studer, “*Radar data processing. Introduction and tracking*” (vol. I). Researches Studies Press. England, John Wiley, 1985.
- [27] A. Farina, F.A. Studer, “*Radar data processing. Advanced topics and applications*” (vol. 2). Researches Studies Press, England, John Wiley, 1986.

- [28] W. Wirth, “*Radar techniques using array antennas*”, The Institution of Electrical Engineers Editions, London, 2001.
- [29] E. Brookner, “Phased-array for the new millennium”, Invited paper, Millennium Conference on Antennas and Propagation, AP-2000, Davos, Switzerland.
- [30] S. Sabatini, M. Tarantino, “*Multifunction Array Radar: System Design and Analysis*”, Artech House, Inc., Norwood (MA), USA, 1994.
- [31] J.B. Billingsley, “*Low-angle radar land clutter: measurements and empirical models*”, Scitech Publishing Inc., William Andrew publishing, IEE, 2002.
- [32] A. Farina, E. Protopapa, “New results on linear prediction theory for clutter cancellation”, IEEE Trans. on Aerospace and Electronic Systems, vol. AES - 24, no. 3, May 1988, pp. 275-286.
- [33] P. Lombardo, M.V. Greco, F. Gini, A. Farina, J.B. Billingsley, “Impact of clutter spectra on radar performance prediction”, IEEE Trans. on Aerospace and Electronic Systems, vol. AES-37, no. 3, July 2001, pp. 1022-1038. B. Carlton, best paper award for 2001.
- [34] F. Gini, M.V. Greco, A. Farina, “Clairvoyant and adaptive signal detection in non-Gaussian clutter: a data-dependent threshold interpretation”. IEEE Trans. on Signal Processing, vol. 47, no. 6, June 1999, pp. 1522-1531.
- [35] A. Farina, F.A. Studer, “A review of CFAR detection techniques in radar systems”. Microwave Journal, Vol. 29, no. 9, September 1986, pp. 115-128.
- [36] J. Ward, “*Space-time adaptive processing for airborne radar*”, MIT Lincoln Laboratory, Technical report TR-1015, December 13, 1994.
- [37] R. Klemm, “*Space Time Adaptive Processing: Principles and applications*”, IEE Radar, Sonar, Navigation and Avionics 9, IEE Press, 1998.
- [38] “*Special issue on STAP*”, *Electronics & Communication Engineering Journal*, vol. 11, no. 1, pp. 1-63, February 1999.
- [39] RTO Lecture Series 228, “*Military applications of Space Time Adaptive Processing*”, September 2002, NATO, Research and Technology Organisation, BP 25, 7 rue Ancelle, F-9221, Neuilly-sur-Seine Cedex France.
- [40] A. Farina, “Electronic Counter-Counter Measures”. Chapter 9 of *Radar Handbook*, 2nd Edition (Editor M.I. Skolnik), McGraw Hill, 1990.
- [41] A. Farina, R. Graziano, F. Lee, L. Timmoneri, “Adaptive space-time processing with systolic algorithm: experimental results using recorded live data”. Proc. of Int. Conf. on Radar, Washington D. C. (USA), May 8-11, 1995, pp. 595-602.
- [42] Y. Bar-Shalom, T. Fortmann, “*Tracking and data association*”, Academic Press, 1988.
- [43] S. Blackman, “*Multiple-target tracking with radar applications*”, Artech House, 1986.

- [44] Y. Bar-Shalom, X-Rong Li, “*Multitarget-multisensor tracking: principles and techniques*”, YBS, 1995.
- [45] P. Bogler, “*Radar principles with applications to tracking systems*”, John Wiley & Sons, New York, January 1990.
- [46] D. Halls, J. Llinas, “*Handbook of multisensor data fusion*”, CRC, 2001.
- [47] S. Julier, J. Uhlmann, H.F. Durrant-Whyte, “A new method for the non linear transformation of means and covariances in filters and estimators”, IEEE Trans. on Automatic Control, vol. AC-45, no. 3, pp. 477-482, March 2000.
- [48] S. Julier, J. Uhlmann, “A new extension of the Kalman filter to nonlinear systems”, in The Proceedings of AeroSense: The 11th International Symposium on Aerospace/Defense Sensing, Simulation and Controls, Orlando, Florida, 1997, SPIE, Multi Sensor Fusion, Tracking and Resource Management II, SPIE volume 3068, pp.182-193.
- [49] A. Doucet, N. de Freitas, N.J. Gordon, editors, “*Sequential Monte Carlo methods in practice*”, New York: Springer-Verlag, January 2001.
- [50] M.S. Arulampalam, S. Maskell, N. Gordon, T. Clapp, “A tutorial on particle filters for on line nonlinear / nonGaussian Bayesian tracking”, IEEE Trans. on Signal Processing, vol. 50, no. 2, pp. 174-188.
- [51] C. Hue, J.-P. Le Cadre, P. Perez, “Sequential Monte Carlo methods for multiple target tracking and data fusion”, IEEE Trans. on Signal Processing, vol. 50, no. 2, pp. 309-325.
- [52] R. Adve, P. Antonik, W. Baldygo, C. Capraro, G. Capraro, T. Hale, R. Schneible, “Knowledge-based application to ground moving target detection”, AFRL-SN-TR-2001-185, In-House Technical Report, September 2001.
- [53] Y. Salama, R. Senne, “Knowledge-based applications to adaptive space-time processing, volume I: Summary”, AFRL-SN-TR-2001-146 vol. I (of vol. VI), Final Technical Report, July 2001.
- [54] H. Schuman, “Knowledge-based applications to adaptive space-time processing, volume II: Airborne radar filtering”, AFRL-SN-TR-2001-146 vol. II (of vol. VI), Final Technical Report, July 2001.
- [55] H. Schuman, “Knowledge-based applications to adaptive space-time processing, volume III: Radar filtering rule book”, AFRL-SN-TR-2001-146 vol. III (of vol. VI), Final Technical Report, July 2001.
- [56] C. Morgan and L. Moyer, “Knowledge-based applications to adaptive space-time processing, volume IV: Knowledge-based tracking”, AFRL-SN-TR-2001-146 vol. IV (of vol. VI), Final Technical Report, July 2001.
- [57] C. Morgan and L. Moyer, “Knowledge-based applications to adaptive space-time processing, volume IV: Knowledge-based tracker rule book”, AFRL-SN-TR-2001-146 vol. V (of vol. VI), Final Technical Report, July 2001.
- [58] Y. Salama, R. Senne, “Knowledge-based applications to adaptive space-time processing. volume VI: Knowledge-based space-time adaptive processing (KBSTAP) user’s manual and programmer’s manual”, AFRL-SN-TR-2001-146 vol. VI (of vol. VI), Final Technical Report, July 2001.

- [59] P. Antonik, H. Schuman, P. Li, W. Melvin, M. Wicks, “Knowledge-based space-time adaptive processing”, Proc. of the IEEE National Radar Conference, Syracuse, NY, May 1997.
- [60] R. Adve, T. Hale, M. Wicks, P. Antonik, “Ground moving target indication using knowledge-based space-time adaptive processing”, Proc. of 2000 IEEE Int. Radar Conference, Washington D.C., pp. 735-740, May 2000.
- [61] W. Baldygo, et. al., “Artificial intelligence applications to constant false alarm rate (CFAR) processing”, Proc. of IEEE 1993 National Radar Conference, 1993, pp. 275-280.
- [62] J.R. Guerci, “Knowledge-Aided Sensor Signal Processing and Expert Reasoning”, in *Proc. 2002 Knowledge-Aided Sensor Signal Processing and Expert Reasoning (KASSPER) Workshop*, Washington DC, 3 April, 2002, Washington DC, CD ROM.
- [63] W.C. Morchin, “*Airborne early warning radar*”, Artech House, 1990.
- [64] F. Gini, A. Farina, M. Greco, “Selected list of references on radar signal processing”, IEEE Trans. on Aerospace and Electronic Systems, vol. AES-37, no. 1, January 2001, pp. 329-359.
- [65] F. Robey, D. Fuhrmann, E. Kelly, R. Nitzberg, “A CFAR adaptive matched filter detector”, IEEE Trans. on Aerospace and Electronic Systems, vol. AES-28, no. 1, January 1992, pp. 208-216.
- [66] P. Bollini, L. Chisci, A. Farina, M. Giannelli, L. Timmoneri, G. Zappa, “QR versus IQR algorithms for adaptive signal processing: performance evaluation for radar applications”. Proceedings of IEE on Radar, Sonar and Navigation, October 1996, vol. 143, no. 5, pp. 328-340.
- [67] C.M. Rader, “Wafer-scale integration of a large systolic array for adaptive nulling”, MIT-Lincoln Laboratory Journal, 1991, vol. 4, no. 1, pp. 3-29.
- [68] L. Timmoneri, I.K. Proudler, A. Farina, J.G. McWhirter, “QRD-based MVDR algorithm for adaptive multipulse antenna array signal processing”, IEE Proc. on Radar, Sonar and Navigation, vol. 141, no. 2, April 1994, pp. 93-102.
- [69] M. Cicolani, A. Farina, E. Giaccari, F. Madia, R. Ronconi, S. Sabatini, “Phased array systems and technologies in AMS”, IEEE International Symposium on Phased Array Systems and Technology, 14-17 October 2003, Boston (Ma). Invited Paper.