

**NORTH ATLANTIC TREATY ORGANIZATION**



**RESEARCH AND TECHNOLOGY ORGANIZATION**

BP 25, 7 RUE ANCELLE, F-92201 NEUILLY-SUR-SEINE CEDEX, FRANCE

**RTO TECHNICAL REPORT 16**

# **Operational Colour Vision in the Modern Aviation Environment**

(la Vision des couleurs dans l'environnement aéronautique opérationnel d'aujourd'hui)

*This report was prepared by Working Group 24 of the Human Factors and Medicine Panel (HFM) of RTO.*

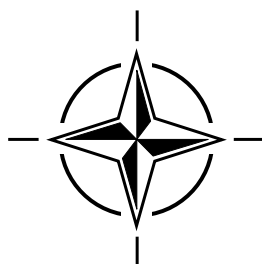

Published March 2001

*Distribution and Availability on Back Cover*

**This page has been deliberately left blank**



**Page intentionnellement blanche**

**NORTH ATLANTIC TREATY ORGANIZATION**

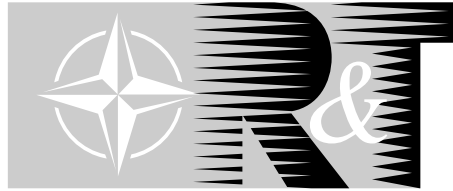

**RESEARCH AND TECHNOLOGY ORGANIZATION**

BP 25, 7 RUE ANCELLE, F-92201 NEUILLY-SUR-SEINE CEDEX, FRANCE

---

**RTO TECHNICAL REPORT 16**

## **Operational Colour Vision in the Modern Aviation Environment**

(la Vision des couleurs dans l'environnement aéronautique opérationnel  
d'aujourd'hui)

### **AUTHORS:**

J.-P. MENU, France, (Working Group Chairman)  
D. IVAN, United States (Working Group Co-Chairman)

F.-J. DAUMANN, Germany  
I. DIAMANTOPOULOS, Greece  
J.L. FIRTH, United Kingdom  
M-F. HEIKENS, Canada  
B. LeBAIL, A. LEGER, France  
J. WALRAVEN, J. ALFERDINCK, The Netherlands  
J.T. YATES, United States

*This report was prepared by Working Group 24 of the Human Factors and Medicine Panel  
(HFM) of RTO.*

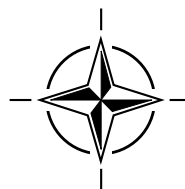

# The Research and Technology Organization (RTO) of NATO

RTO is the single focus in NATO for Defence Research and Technology activities. Its mission is to conduct and promote cooperative research and information exchange. The objective is to support the development and effective use of national defence research and technology and to meet the military needs of the Alliance, to maintain a technological lead, and to provide advice to NATO and national decision makers. The RTO performs its mission with the support of an extensive network of national experts. It also ensures effective coordination with other NATO bodies involved in R&T activities.

RTO reports both to the Military Committee of NATO and to the Conference of National Armament Directors. It comprises a Research and Technology Board (RTB) as the highest level of national representation and the Research and Technology Agency (RTA), a dedicated staff with its headquarters in Neuilly, near Paris, France. In order to facilitate contacts with the military users and other NATO activities, a small part of the RTA staff is located in NATO Headquarters in Brussels. The Brussels staff also coordinates RTO's cooperation with nations in Middle and Eastern Europe, to which RTO attaches particular importance especially as working together in the field of research is one of the more promising areas of initial cooperation.

The total spectrum of R&T activities is covered by the following 7 bodies:

- AVT Applied Vehicle Technology Panel
- HFM Human Factors and Medicine Panel
- IST Information Systems Technology Panel
- NMSG NATO Modelling and Simulation Group
- SAS Studies, Analysis and Simulation Panel
- SCI Systems Concepts and Integration Panel
- SET Sensors and Electronics Technology Panel

These bodies are made up of national representatives as well as generally recognised 'world class' scientists. They also provide a communication link to military users and other NATO bodies. RTO's scientific and technological work is carried out by Technical Teams, created for specific activities and with a specific duration. Such Technical Teams can organise workshops, symposia, field trials, lecture series and training courses. An important function of these Technical Teams is to ensure the continuity of the expert networks.

RTO builds upon earlier cooperation in defence research and technology as set-up under the Advisory Group for Aerospace Research and Development (AGARD) and the Defence Research Group (DRG). AGARD and the DRG share common roots in that they were both established at the initiative of Dr Theodore von Kármán, a leading aerospace scientist, who early on recognised the importance of scientific support for the Allied Armed Forces. RTO is capitalising on these common roots in order to provide the Alliance and the NATO nations with a strong scientific and technological basis that will guarantee a solid base for the future.

The content of this publication has been reproduced directly from material supplied by RTO or the authors.

Published March 2001

Copyright © RTO/NATO 2001  
All Rights Reserved

ISBN 92-837-1026-6



*Printed by St. Joseph Ottawa/Hull  
(A St. Joseph Corporation Company)  
45 Sacré-Cœur Blvd., Hull (Québec), Canada J8X 1C6*

# **Operational Colour Vision in the Modern Aviation Environment**

**(RTO TR-016 / HFM-012)**

## **Executive Summary**

The essential aim of this multidisciplinary teamwork, which has been in operation for several years, is to correctly position the use of colour vision in the field of aeronautics. It is now time to assimilate the latest data on the mechanism of colour vision and adapt it functionally to the applications encountered in aeronautics. This task-adapted, functional or ergonomic approach is sustained throughout the various chapters of this report. The most eminent European and American specialists, involved daily in this application, all made contributions to this document.

Following a recap of the theoretical bases of colour vision, three major groups of development emerge. The first concerns techniques and the use of colour screens. The second deals with the tests currently used to assess colour vision. We would mention at this stage that very few tests directly examine professional colour sense, whereas this is what needs to be assessed in an application situation. The tests were developed by clinicians for detecting pathologies. Only rarely do they bear any close relation to the tasks actually carried out.

How can this situation be improved? A model derived from an understanding of the handicap can be used as a basis. When adapted to aeronautical situations, it enables us to see that the most important thing is not the diagnosis of a pathology, but the demonstration of the inability to perform certain activities and the social impact, or the social handicap which results from this. The 'professional' tests for colour sense (and not colour vision) can be presented as part of the third group of developments. Comparison of the model previously described (derived from the international classification of handicap) with modern technology has led to an approach which has been summarised in a general document prepared by all the authors with a view to practical application. The standards applied by each nation are presented and discussed. The aims of the overall document are to present this ergonomic approach and these new assessment procedures. Once these principles are understood and begin to be applied, in future years, new examination procedures will certainly emerge, helped by microcomputing, the use of databases and, why not, Internet?

# **la Vision des couleurs dans l'environnement aéronautique opérationnel d'aujourd'hui**

**(RTO TR-016 / HFM-012)**

## **Synthèse**

L'objectif essentiel de ce travail effectué en équipe multidisciplinaire pendant plusieurs années est de bien positionner l'utilisation de la vision des couleurs dans le domaine aéronautique. Il est temps en effet de prendre en compte les données les plus récentes sur le fonctionnement de la vision des couleurs et de les adapter fonctionnellement aux applications rencontrées en aéronautique. Tout au long des chapitres de cet ensemble, cette approche fonctionnelle ou ergonomique, adaptée à la tâche sera conservée.

Les plus grands spécialistes européens, américains impliqués journalièrement en vue de cette application ont participé à la rédaction des différents chapitres. C'est ainsi que l'on distingue après les bases théoriques sur la vision des couleurs, trois grands groupes de développements. Le premier concerne les techniques et l'utilisation des écrans colorés. Le second s'intéresse aux tests utilisés couramment pour évaluer la vision des couleurs. Mentionnons à ce stade que très peu de tests interrogent directement le sens coloré professionnel alors qu'en situation d'application c'est lui que l'on doit estimer. Les tests ont été développés par des cliniciens pour dépister des pathologies. Ils ne sont que rarement en relation très étroite avec les tâches réalisées concrètement.

Comment améliorer cette situation ? Un modèle dérivé de la prise en compte du handicap peut servir de base. Adapté aux situations aéronautiques, il permet de mieux comprendre que l'important n'est pas le diagnostic d'une pathologie mais la mise en évidence d'incapacités à effectuer certaines activités et le retentissement social, ou le désavantage social que cela induira. Les tests dits « professionnels », du sens coloré (et non de la vision des couleurs) peuvent être présentés au cours du troisième groupe de développements. La confrontation du modèle précédent (dérivé de la classification internationale du handicap) et des technologies modernes conduit à proposer une approche qui fait l'objet de la synthèse générale rédigée par l'ensemble des auteurs dans un objectif d'application pratique. Les standards appliqués par chaque pays sont présentés et sont discutés. Les objectifs de l'ensemble du document sont cette approche ergonomique et ces nouvelles procédures d'évaluation. A partir de la compréhension, de l'application de ces principes, émergeront certainement dans les années à venir de nouvelles procédures d'examen aidé en cela par la microinformatique, l'utilisation de bases de données et pourquoi par l'Internet.

# Contents

	<b>Page</b>
<b>Executive Summary</b>	<b>iii</b>
<b>Synthèse</b>	<b>iv</b>
<b>Preface/Préface</b>	<b>x</b>
<b>List of Figures and Tables</b>	<b>xi</b>
<b>Human Factors and Medicine Panel Officers</b>	<b>xiii</b>
<b>Chapter 1 – Introduction</b>	<b>1</b>
1.1 General Considerations	1
1.2 Towards a New Generation of Tests	2
1.3 The Need for an Objective Assessment of Colour	2
1.4 International Classification of Handicap	2
<b>Chapter 2 – The Visual Nervous System and its Neurophysiology</b>	<b>5</b>
2.1 General Plan for a Sensory System	5
2.2 Adequacy of Animal Models for Human Colour Vision	5
2.3 Peripheral Transducer Properties (Retina)	5
2.4 The Visual System's Thalamic Relay: The Lateral Geniculate Nucleus	6
2.5 The Visual Cortices: V1, V2, V3	7
2.5.1 Spatial Responses	7
2.5.2 Chromatic Responses: Oriented Cells	7
2.5.3 Non-Oriented Cells	7
2.5.4 Non-Oriented Colour Cells	7
2.6 Cortical Area V4	8
2.7 Summary	8
2.8 Other Electro-Physiological Techniques in Colour Vision	8
2.8.1 Electroretinography (ERG)	8
2.8.2 Visual Evoked Response (VER)	9
2.9 References	9
<b>Chapter 3 – Recent Progress in Colour Vision</b>	<b>11</b>
3.1 Introduction	11
3.2 New Standard for Cone Spectral Sensitivities	11
3.2.1 Cone Fundamentals	12
3.2.2 Interocular Media	12
3.2.3 Cone Pigments	13
3.2.4 Molecular Genetics of Cone Pigments	13
3.3 Defective Colour Vision	14
3.3.1 New Prospects?	14
3.3.2 Visualisation of Colour Deficient Vision	14

3.4	Colour in Context	16
3.4.1	Chromatic Induction	16
3.4.2	Colour Constancy	16
3.5	Colour Processing Beyond the Retina	16
3.6	Concluding Remarks	17
3.7	References	17
<b>Chapter 4 – Colour Vision Testing – Methodologies: Update and Review (The Basis of Colour Vision Testing - Hereditary Defects)</b>		<b>21</b>
4.1	Specification of Colours	21
4.2	Metamers and Colour Vision	22
4.3	Hereditary Colour Vision Defects	22
4.4	Testing Theory/Methodology	22
4.4.1	Review of Common Test Devices	22
4.4.2	Lantern Tests	24
4.5	Test Administration	25
4.5.1	Plate Tests	25
4.5.2	Arrangement Tests	25
4.5.3	Lantern Tests	25
4.6	Specific Tests	26
4.6.1	Anomaloscopes (Other than Nagel)	26
4.6.2	Pseudo-isochromatic Plate Tests	26
4.6.3	Arrangement Tests	29
4.6.4	Lantern Tests	30
4.6.5	Other Tests	32
4.6.6	Emerging Technologies	32
4.7	References	36
<b>Chapter 5 – Acquired (Transient and Permanent) Colour Vision Disorders</b>		<b>43</b>
5.1	Colour Deficits – Acquired	43
5.1.1	Type I Acquired Red-Green Deficits	43
5.1.2	Type II Acquired Red-Green Deficits	43
5.1.3	Type III Acquired Blue-Yellow Deficits	44
5.2	Colour Vision Disorders Caused by Illness	44
5.3	Colour Vision Disorders Caused by Physical and Physiological Influences	45
5.4	Drug-Induced Colour Vision Side Effects	45
5.4.1	General Principles	45
5.4.2	Medications	45
5.4.3	Testing Procedures for Acquired Colour Vision Defects	46
5.5	References	46
<b>Chapter 6 – A Review of NATO Aviation Colour Vision Testing Methodologies and Standards</b>		<b>53</b>
6.1	Belgium	53
6.2	Canada	53
6.2.1	The Civil Aviation Administration (CAA) (Canada)	54
6.3	Denmark	54
6.4	France	54
6.5	Germany	55
6.6	Greece	55
6.7	Italy	55
6.8	The Joint Aviation Requirements (JAR)	55



6.9	Netherlands	55
6.10	Norway	55
6.11	Portugal	56
6.12	Spain	56
6.13	Turkey	56
6.14	United Kingdom	56
6.15	United States	56
6.15.1	US Air Force (USAF)	56
6.15.2	US Army (USA)	57
6.15.3	US Navy (USN)	57
6.15.4	The Federal Aviation Administration (FAA)	57
6.16	Conclusion	58
<b>Chapter 7 – Visual Ergonomics of Colour-Coded Cockpit Displays: A Generic Approach</b>		<b>73</b>
7.1	Introduction	73
7.2	Display Technology	73
7.2.1	Selection of Display Options	73
7.2.2	LCD Technology Options	74
7.3	Visual Standards	75
7.3.1	Convergence on the ISO Standards	75
7.3.2	Military Standards	75
7.4	Elementary Human Factors Considerations	75
7.5	Ambient Light	80
7.5.1	Contrast Reduction by Ambient Light	80
7.5.2	Ambient Light in the Cockpit	80
7.5.3	Reflected Light Computations	81
7.5.4	Colour Washout	81
7.5.5	Physiological Effects of Ambient Light	81
7.5.6	Polarity of Luminance Contrast	82
7.6	References	82
<b>Chapter 8 – Display Technology: A Generic Approach</b>		<b>85</b>
8.1	Display Technology Classification of Displays	85
8.2	Analysis of the Different Classes	85
8.2.1	Plasma Screens	85
8.2.2	Electro-Luminescent Colour Screens	86
8.2.3	Colour Cathodoluminescent Matrix Screens	86
8.2.4	Colour Cathode Ray Tubes	86
8.2.5	Central Colour Vision Matrix LCDs	87
8.2.6	General Presentation of LCD Screens (Central vision or not)	87
8.3	TRC Overhead Projectors	88
8.4	LCD Colour Projectors and Overhead Projectors	89
8.4.1	Light Sources	89
8.4.2	Colour Synthesis	89
8.5	Miscellaneous Projection Systems	89
8.5.1	Micro-Mirror Matrix (DMD: Digital Micro-Mirror Device)	89
8.5.2	Deflected Laser Beam System	89

<b>Chapter 9 – Optical and Electro-Optical Devices: Consequences for Colour Vision</b>	<b>91</b>
9.1 Laser Eye Protection	92
9.2 Specialised Laboratory Analyses	94
9.3 Prosthetic Colour Filters	94
9.4 Night-Vision Goggles (NVG)	94
9.5 CRT Screens	95
9.6 References	96
<b>Chapter 10 – Current Colour Issues in Military Aviation</b>	<b>97</b>
10.1 External Navigational Aids	98
10.2 Air Traffic Controllers	99
10.3 Optical Appliance Effects	100
10.3.1 Selective Waveband Filters	100
10.3.2 Night-Vision Devices (NVDs/NVGs)	101
10.4 Target Discrimination	101
10.4.1 Air-to-Ground Operations	101
10.4.2 Air-to-Air Operations	102
10.5 Aircraft Carrier Operations	102
10.5.1 US Navy	102
10.6 Search and Rescue	103
10.7 Summary	104
10.8 References	104
10.9 Additional Reading	105
<b>Chapter 11 – Colour Vision Concerns in Aviation – Clinical Concerns on Colour Coding in Aviation</b>	<b>109</b>
11.1 Introduction	109
11.2 Specific Threats to Colour Vision Performance	111
11.2.1 Congenital	111
11.2.2 Acquired Colour Deficit	112
11.2.3 Practicalities	115
11.3 Clinical Requirements	116
<b>Chapter 12 – Conclusions and Recommendations</b>	<b>117</b>
12.1 Testing Recommendations	117
12.2 Tests	117
12.2.1 Testing Congenital Defects	117
12.2.2 Testing Acquired Defects	117
12.2.3 Relevant Tests	118
12.3 Colour Specification	118
12.4 ISO	118
12.5 Displays - Appliances	118
12.6 Issues	118
12.6.1 Requirements - Present	118
12.6.2 Requirements - Future	118
12.6.3 Colour Use/Ergonomics	118
12.7 Research	119
12.7.1 Extended Research on Polychromatic Cockpit Displays	119

<b>Appendix 1 – Basic Concepts and Terminology in Colour Engineering</b>	<b>121</b>
A1.1 Introduction	121
A1.2 Physiological Basis	121
A1.3 Colour Space and Colour Perception	121
A1.4 The Colour Palette of a CRT	123
A1.5 Some Basic Terms and Units Related to Light and Vision	124
A1.5.1 Perception	124
A1.5.2 Colourimetry	125
A1.5.3 Photometry	125
A1.5.4 Radiation	126
A1.6 References	126
<b>Appendix 2 – Common Colour Vision Testing, Apparatus and Manuals</b>	<b>127</b>
A2.1 Testing Procedures	127
A2.1.1 General Considerations	127
A2.2 Instruction Manuals (Abridged)	127
A2.2.1 Dvorine Pseudo-isochromatic Plates	127
A2.2.2 The City University Colour Vision Test	129
A2.2.3 Standard Pseudo-isochromatic Plates II (SPPII)	130
A2.2.4 The Farnsworth Dichotomous Test for Colour Blindness (Panel D-15)	131
A2.2.5 Rodenstock Colour Vision Test	134
A2.2.6 Lanthony's Desaturated 15 Hue Test according to Farnsworth-Munsell	135
A2.2.7 Farnsworth Lantern (FALANT)	137
A2.2.8 Lanthony New Colour Test	138
A2.2.9 AQT-6 Colour Vision Tester	139
A2.2.10 Nagel Anomaloscope	141
A2.2.11 Moreland Anomaloscope	143
A2.2.12 Farnsworth-Munsell 100 Hue Test	145
A2.2.13 PROCOPAT Software	148
<b>Appendix 3 – General Glossary</b>	<b>155</b>

# Preface

The purpose of this document, which is a result of the coming together and the operation over several years of a multidisciplinary NATO Working Group is, on the one-hand, to define the role and the place of colour in modern aeronautical systems, and also to offer physicians and the vision specialists working on the evaluation of colour vision or professional colour sense a systematic approach and the most suitable test procedures. Moreover, as the group was composed of members from several different countries, it proposed to develop a common approach to the exploration of professional colour vision sense. In the future, it will in fact be much easier to compare the results achieved and the problems and difficulties encountered by an operator during the course of their activities. A database-type system along these lines should be set up on an international basis.

The results of this work are intended primarily for physicians and other vision specialists responsible for determining visual aptitude in aeronautics, but the findings and recommendations are also relevant to land and naval applications. It is also aimed at other fields of occupational medicine in which engineers developing new systems using colour may better understand the whole range of human colour perception.

The 12 chapters of the document which you have in your hands cover the whole field of professional colour vision sense in its various neurophysiological and medical dimensions, and at the same time, provide information on more technical aspects concerning the physics of colours and luminous environments as well as the technologies of coloured symbology generation. Finally, those responsible for determining professional colour vision aptitude will also find here all the tests and procedures applicable today. They will discover that in addition to a clinical, diagnostic oriented approach, there is a real attempt to achieve an ergonomic solution based on the performance of a task in which colour plays an essential role. From the point of view of aptitude, this means that a series of professional ergonomic ability tests can be used, which will be of great diagnostic benefit to the medical practitioner.

None of this work would have been possible without the support of the former AGARD Aerospace Medical Panel (AMP).

# Préface

Le but de ce document, issu de la réunion et du fonctionnement pendant plusieurs années d'un groupe de travail multidisciplinaire de l'OTAN, est d'une part de faire le point sur la place et le rôle de la couleur dans les systèmes aéronautiques mais aussi de proposer aux médecins chargés de l'évaluation de la vision des couleurs ou du sens coloré professionnel, une démarche systématique et des procédures de tests les plus adaptés possibles. Par ailleurs, le groupe étant formé d'experts de multiples pays, se proposait de développer une démarche commune d'exploration du sens coloré professionnel. En effet à l'avenir il deviendra ainsi possible de comparer plus aisément les résultats obtenus et de discuter plus facilement les problèmes et difficultés rencontrés par un opérateur dans l'exercice de ses activités. Un système de type de base de données sur cette thématique devrait être mis en place à un niveau international.

Les résultats de ce travail s'adressent surtout aux médecins chargés de déterminer une aptitude visuelle en aéronautique et s'appliquent également à la marine et à l'armée de terre. Ils sont aussi destinés à d'autres domaines de la médecine du travail où les ingénieurs chargés du développement d'un nouveau système utilisant la couleur, y trouveront toutes les facettes de la perception humaine de la couleur.

Le document que vous avez entre les mains, permet en douze chapitres de couvrir l'ensemble du domaine du sens coloré professionnel dans ses diverses dimensions neurophysiologiques, médicales, tout en donnant quelques informations sur des aspects plus techniques sur la physique de la couleur et des ambiances lumineuses et les technologies de génération de symbologies colorées. Enfin, le médecin chargé de déterminer une aptitude professionnelle trouvera tous les tests et procédures applicables aujourd'hui. Il pourra constater qu'au-delà d'une démarche clinique à visée diagnostique existe une véritable approche ergonomique, centrée sur la réalisation d'une tâche dans laquelle la couleur joue un rôle essentiel. En conséquence au niveau de l'aptitude il s'agit de mettre en œuvre des tests de capacité professionnelle ergonomique, apportant un confort de diagnostic au praticien.

L'ensemble du travail n'a été possible que grâce au support du Panel de Médecine Aérospatiale de l'ancien AGARD (Groupe Consultatif pour la Recherche et les Réalisations Aérospatiales).

# List of Figures and Tables

	<b>Page</b>
<b>Figures</b>	
Figure 1.1	4
Figure 3.1	12
Figure 3.2	12
Figure 3.3	13
Figure 3.4	15
Figure 7.1	78
Figure A1.1	122
Figure A1.2	123
Figure A1.3	124
Figure A2.1	128
Figure A2.2	129
Figure A2.3	130
Figure A2.4	132
Figure A2.5	133
Figure A2.6	134
Figure A2.7	136
Figure A2.8	137
Figure A2.9	139
Figure A2.10	140
Figure A2.11	142
Figure A2.12	144
Figure A2.13	147
Figure A2.14	148
Figure A2.15	150
Figure A2.16a	151
Figure A2.16b	151
Figure A2.17	152
Figure A2.18	153

**Tables**

Table 1.1	The International Classification of Handicap (ICH) Concept	2
Table 4.1	USNMRL Test battery for determining degree of colour vision defect	35
Table 4.2	Review of the plate tests available for colour vision clinical assessments	38
Table 4.3	Review of the arrangements tests available for colour vision clinical assessments	40
Table 4.4	Review of lantern tests available for colour vision clinical assessments	41
Table 5.1	Characteristics of congenital vs. acquired colour vision (CV) defects	43
Table 5.2	Acquired colour vision defects excluding those from physical agents	48
Table 5.3	A group of medications known to affect colour vision	50
Table 6.1	NATO Aircrew colour vision tests	59
Table 6.2	Frequency of colour vision testing in NATO aircrew	60
Table 6.3	Colour vision testing methodology by country	61
Table 7.1	Overview of ISO requirements for displayed colours	77
Table 7.2	Display contrast of CRT and LCD displays for worst-case lighting conditions, for the case of 5% incident light on the display surface.	81
Table 9.1	Aircrew Laser Eye Protection (ALEP) effects	93
Table 10.1	Airport lighting (USA/Canada)	105
Table 10.2	Airport lighting (Europe)	106
Table 10.3	Shipboard helicopter landing lighting (NATO STANAG 1275)	106
Table 10.4	Flight deck jersey colour coding on US aircraft carriers	107
Table 10.5	Aircraft carrier lighting system	107
Table 11.1	The nature of colour vision incapacitation	111
Table 11.2	Aviation activities and equipment as related to colour vision requirements and consequences	116
Table 12.1	Summary of WG24 colour vision testing recommendations	120
Table A1.1	Perceptual attributes of a colour and it's physical correlates	122

# Human Factors and Medicine Panel Officers

**Chairperson:** M.C. WALKER  
Director, Centre for Human Sciences  
F138 Bldg — Room 204  
DERA, Farnborough, Hants GU14 0LX  
United Kingdom

**Deputy Chairman:** W.D. TIELEMANS  
RNLA/SGO, P O Box 20703  
Binckhorstlaan, 135  
2500 ES The Hague  
The Netherlands

## WORKING GROUP 24 MEMBERS

**Chairman/Author**  
J-P. MENU  
Institut de Médecine Navale du  
Service de Santé des Armées  
BP 610  
83800 Toulon Naval, France  
Tel: +33 (0)4 94 09 91 68  
Email: [jp.menu@wanadoo.fr](mailto:jp.menu@wanadoo.fr)

**Co-Chairman/Author**  
D.J. IVAN  
Chief, Ophthalmology Branch  
USAFSAM  
2507 Kennedy Circle  
Brooks AFB, Tx 78235-5117, United States  
Tel: +1 210 536 3241  
Email: [douglas.ivan@brooks.af.mil](mailto:douglas.ivan@brooks.af.mil)

## Members/Authors

F-J. DAUMANN  
Flugmedizinisches Institut der Luftwaffe  
82242 Fuerstenfeldbruck  
Germany

I. DIAMANTOPOULOS  
251, Air Force Hospital  
Messogion & Katechaki Ave.  
11525 Athens  
Greece

J.L. FIRTH  
Aviation Neurology Group  
Clinical Neurosciences Directorate  
Queen's Medical Centre  
Nottingham, NG7 2UH  
United Kingdom

M-F. HEIKENS  
DCIEM, P O Box 2000  
1133 Sheppard Avenue West  
North York, Ontario M3M 3BQ  
Canada

A. LEGER  
Sextant Avionique  
Rue Toussaint Catros  
33160 Saint Médard en Jalles, Cedex  
France

J. WALRAVEN  
TNO Human Factors Research Institute  
Kampweg 5,  
3769 ZG Soesterberg  
The Netherlands

J.T. YATES  
USAFSAM, 2507 Kennedy Circle  
Brooks AFB, Tx 78235-5117  
United States

## Co-Authors

B. LeBAIL  
Service Ophtalmologie  
CPEMPN, Hôpital d'Instruction des Armées  
101 Ave. Henri Barbusse  
92141 Clamart  
France

J.W.A.M. ALFERDINCK  
TNO Human Factors Research Institute  
Kampweg 5, 3769 ZG Soesterberg  
The Netherlands

## Technical Support

M. BATAILLE, FR (IMASSA)  
D. GRASSET-MICHEL, FR (RTA)

## PANEL EXECUTIVE

C. Wientjes  
BP 25, 7, rue Ancelle  
92201 Neuilly-sur-Seine Cedex  
France  
Tel: +33 (0)1 55 61 22 60/62  
Fax: +33 (0)1 55 61 22 99/98  
E-Mail: [wientjesc@rta.nato.int](mailto:wientjesc@rta.nato.int)

**This page has been deliberately left blank**



**Page intentionnellement blanche**



# Chapter 1

## Introduction

Jean-Pierre Menu

Colour occupies an increasingly important place in our everyday life, but also in the field of aeronautics which is the subject of this document.

In the past, very few colours were actually used apart from red to signify “stop” and green to signify “ok”.

Today, colour is used in the cockpits of civil and military aircraft and will soon be used for air traffic control radar screens.

This state of affairs has certain consequences for the professional colour perception capacities of any given individual. Someone with a colour vision anomaly which can be detected using ophthalmological tests freely available on the market will not be permitted to carry out certain functions. However, it should be noted that these tests are not ideal, since they do not reproduce the professional conditions of colour vision stimulation, which has resulted in the adoption of new tests known as the Colour Perception Professional Capacity Tests (CPPC). This professional colour sense test was first developed for aircraft pilots and later adapted to air traffic controllers.

This document will therefore attempt a general summary of the operational use of colour in aeronautics.

It contains 12 chapters, providing reminders of the technologies available for colour creation, analysis of the bases of the visual perception of colours and ophthalmological tests currently used to detect colour vision anomalies.

An approach based on the international classification of handicaps (which might seem somewhat removed from the subject of pilot vision), will enable the development of a functional rather than a clinical approach to colour perception. It is the basis of the development of the new generation of colour sense tests, some of which will be presented and discussed.

### 1.1 GENERAL CONSIDERATIONS

The electromechanical instruments on the instrument panels of previous generation civil or military aircraft only had a limited number of colours, that is to say essentially red, to show alarms and green, to indicate “all ok”.

Colours were essentially located outside the cabin; the blue runway beacons were used for taxiing at night; the flashing red green and white lights to indicate the presence of the aircraft, and if necessary, red and green flares to illuminate runways not equipped with radio guidance.

These were therefore very particular types of stimulation, of relatively short display time.

Today, colour is used on the instrument panels of most military and civil aircraft, either in the head up display (HUD) the head down display (HDD), television tubes, or liquid crystal screens, all of which use fairly complex, differently coloured symbologies.

In civil aeronautics, in the Airbus A310 and the A320, in the new versions of the Boeing and even in business jets, all CRTs display a variety of coloured alpha-numerical and analogue data, for flight management and control.

This is polychromatic data (more than eight colours, each of which can be displayed at different light intensities) with varied graphics, ranging from very small areas (alphanumeric, scale graduations) to larger areas (backgrounds, sky, ground). It also represents the majority of the problems encountered with the new generation of “glass cockpit” aircraft.

There are therefore important differences between past and present situations involving colour vision. The increasing use of colour in different types of military and civil aircraft repeatedly raises the problem of the precise evaluation of colours by any given individual. The same problem occurs for air

traffic controllers who will soon be using radar colour screens, following the development of a palette of colours suited to the air traffic controller's task.

## 1.2 TOWARDS A NEW GENERATION OF TESTS

Generally speaking, colour vision aeronautical aptitude tests were created for reasons of safety and perception of the world outside the aircraft, whereas today, exterior indicators such as flares are almost redundant, and colour has entered the cockpit (colour liquid crystal displays or cathode ray tubes). What is more, these colours may change over time or depending on the light environment (desaturation of colours or bleaching of primary colours with the increased illumination at high altitude).

The conditions governing the use of colour have therefore changed:

- the pilot observes these colour screens for long periods (for several minutes or even hours).
- colour does not just have a safety connotation; it acquires one as part of the task itself. Colour coding enables time saving in the uptake of information; for example, the colour yellow is reserved for power information, the colour magenta for track or trajectory processing. Some practical examples of techniques and symbologies are given in Chapter 8 by Alain Léger.
- complex images have several juxtaposed or superimposed colours. The intensity contrast between a colour and a black background is no longer valid. Coloured contrast is commonly used.

Finally, colour screens are generally observed at a distance of 60 cm.

Visual acuity varies under these conditions. Confusion may arise following even minor modifications of these parameters. Given this statement of the problem then, we should reconsider the tests to be used and define new tests

suited to suit this new type of coloured stimulation.

The above mentioned conditions are adequate for their definition. **These are professional tests which present the whole range of aeronautical colours under spatial, temporal and light intensity conditions as close as possible to those of actual use.**

## 1.3 THE NEED FOR AN OBJECTIVE ASSESSMENT OF COLOUR

Colours should not just be assessed subjectively (depending on the assessment of the observer: response of the type: "it's red: it's pink; it's violet..."), as the variability and scatter of opinions is too great. They have to be measured and quantified using a metric developed by the Commission Internationale de l'Eclairage (CIE) also known as the International Commission on Illumination (ICI), which is illustrated in Figure 1.1. This enables measurement within a standardised scale representing all the colours used, and after photocolourimetric measurements, the trichromatic coordinates  $x$  and  $y$  are defined, as well as the luminance expressed in candela per square metre.

Chapter 7 by J. Walraven and the corresponding Annexes describe objective ways of characterising a given colour in the most precise way possible. This metric is absolutely essential for any colour characterisation.

## 1.4 INTERNATIONAL CLASSIFICATION OF HANDICAP

The purpose of the international classification of handicap (ICH) is to provide a conceptualisation of information concerning the long-term consequences of illnesses, traumas, and other ailments. There is a link between four separate concepts which are well defined by the ICH: illness, deficiency, incapacity and handicap (see Table 1.1).

**Table 1.1: The International Classification of Handicap (ICH) Concept**

ILLNESS⇒	DEFICIENCY⇒	INCAPACITY⇒	DISADVANTAGE
↓	↓	↓	↓
Intrinsic situation	Exteriorised situation	Objectivised situation	Socialised situation

Illness is the fact that something abnormal is happening to an organ or to an individual. The objective sign of these deficiencies is when someone becomes aware of the fact (for example visual acuity is diminished, or colour vision is modified). Capacity or incapacity are shown directly in the ability of an individual, given the total possibilities of his organism, to perform a given task. This, then, is an ergonomic approach. In the final analysis, the term handicap or disadvantage shows that, depending on his abilities, a person can belong to a certain group (thus a visual acuity deficiency would result in the inability to pilot an aircraft and, as a result, in the impossibility of belonging to a group of pilots).

This ICH should serve as a guideline for any expert approach. Will the tests used for colour be designed in such a way as to define effective colour vision as clearly as possible (as an illness) or as the incapacity to pilot an aircraft? Under these conditions we can therefore consider that colour vision deficiency tests are not tests of professional colour sense, that they do not provide the same information, and do not have the same aims.

Most of the tests used today have been developed with a bias towards deficiency using a clinical rather than an ergonomic approach. Our aim here is to follow as closely as possible the different tasks and activities.

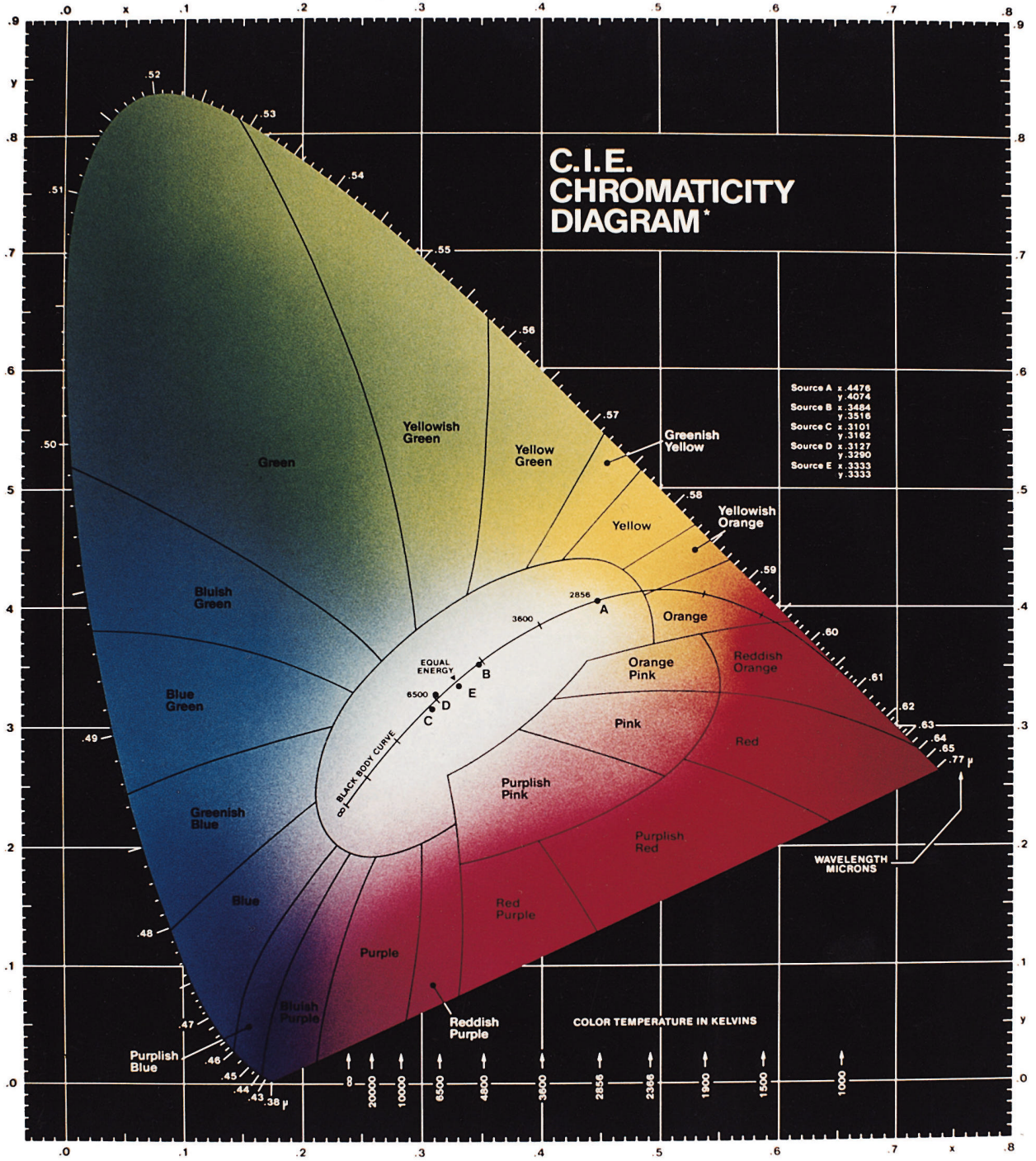

Figure 1.1: CIE Chromaticity Diagram

## Chapter 2

# The Visual Nervous System and its Neurophysiology

J. Terry Yates

### 2.1 GENERAL PLAN FOR A SENSORY SYSTEM

Most sensory systems follow a similar “plan” of organisation. There is a **Peripheral Transducer** that converts physical energy into an electrical current. In the case of the visual system Ragnar Granit (1947) observed that the leading edge of the electroretinogram (a complex set of electrical events within the eye in response to light) was derived from the photoreceptors. Peculiarly, the ERG polarity seemed to indicate hyperpolarising photoreceptor events associated with light exposure. All other neural cells investigated at the time were passively hyperpolarised when at rest and were depolarised when stimulated.

The next stage of conduction through the nervous system in the “plan” is a **Specific Thalamic Relay Nucleus** which usually repeats information from the transducers with little signal modification. This repeater helps in the process of sending signals over long distances; in this case, from the eye to the brain. The relay nucleus for the visual system is called the Lateral Geniculate Nucleus (LGN). It receives inputs from the optic nerve and sends outputs to the next stage of processing.

That stage involves a **Cortical Projection Area**. The mantle of the brain (cortex) receives a map of the receptor surface (retina) with distortions based on peripheral innervation density. One millimetre of fovea projects to six millimetres of cortex. Colour vision depends in large part on that foveal projection. Other retinal regions have one millimetre of cortex devoted to servicing one millimetre of retina. (Sholl, 1956)

### 2.2 ADEQUACY OF ANIMAL MODELS FOR HUMAN COLOUR VISION

A variety of species, both poikilotherms (cold blooded) and homeotherms (warm blooded) have had the physiology of their colour vision studied

and some were found to be better models of human vision than others.

Fishes, turtles and frogs have had various retinal elements evaluated *in vivo*, since recording electrical events from higher animals is quite difficult. All have photoreceptors (cones) and other retinal elements that show good colour discrimination. (Svaetichin, 1953; Tomita, 1963)

Felines have poor or negligible colour discrimination; and, indeed, they are afoveate, nocturnal and possess very few cones.

Primates are a better choice, if carefully selected. Old World primates such as the macaque monkeys and the great apes have colour discrimination much like humans; a fact that is further reflected in the presence of a true fovea with cone photoreceptors. They are diurnal, as are humans and many other aspects of the primate eye resemble *homo sapiens*. New World monkeys (organ-grinder type monkeys) are colour defective and resemble the anomalous trichromats (protanomalous and deuteranomalous trichromats). Ex: squirrel monkeys are protanomalous (DeValois, 1965).

### 2.3 PERIPHERAL TRANSDUCER PROPERTIES (RETINA)

Cone photoreceptors contain pigments that catch light and convert the information into electrical signals that are processed and sent to the brain. Early experiments involve microspectrophotometry in human cadavers and rhesus monkey retinae (Marks et al., 1964). That procedure sends lights of different wavelengths through the outer part of the cone photoreceptors and measures the amount that is absorbed. Three classes of pigments were found, with peak absorption in the “red”, “green” and “blue” regions of the spectrum.

An *in vivo* technique has provided additional evidence that there are, in fact, three classes of

photoreceptors (Rushton, 1963, 1965; Rushton and Henry, 1968). Light delivered to a human eye is incompletely absorbed by the photoreceptors and some of it is reflected back out of the eye. By changing the wavelength of the light entering the eye, in an organised way, and capturing the reflected light with very sensitive instruments, the absorption characteristics of the three receptor classes may be estimated.

Three pigments have been described:

Erythrolabe - a "red" catcher

Chlorolabe - a "green" catcher

Cyanolabe - a "blue" catcher

Those spectra were found to be rather broadly tuned and to overlap; an important issue when trying to understand colour vision deficits.

It is a safe assumption that the human eye and that of many other primate species has three classes of photoreceptors that are involved in colour vision.

At this point, however, no dynamic physiology had been demonstrated, only the process of light absorption by retinal elements had been shown to occur. The question to be asked was: "Does this have something to do with seeing?"

Cone outer segments may be penetrated with a tiny microelectrode and changes in electrical activity recorded when the cell is exposed to light. Tomita, (1965) showed that cones hyperpolarise in the presence of light and depolarise in the dark; that is, there is measurable electrical activity that is directly related to stimulation by light. Three sorts of hyperpolarisation patterns were seen corresponding to the activity of:

Blue  
Green } Cones  
Red

These data agree well with the microspectrophotometric data, mentioned above, and the photochemical, electrophysiological basis for colour vision was beginning to be understood.

Horizontal cells are found in the pathway from distal to proximal retina and are undoubtedly involved in the transduction process, since they are connected to the photoreceptors. They exist in two forms as described by Svaetichin (1953), who first recorded electrical activity from them. C(olour)-

cells, whose inputs are exposed to chromatic lights ("colour") hyperpolarise for some wavelengths and depolarise for others. That is, they increase their electrical activity or decrease it depending on the "colour" of the light. There were two sorts of response classes discovered indicating "red-green" and "blue-yellow" coding. This sort of response pattern has been labelled opponent colour coding since the electrical polarity is positive for part of the spectrum and negative for the rest.

L(uminosity) cells exist in two different forms; ones that depolarise for all spectral hues and others that hyperpolarise for the same hues. They are not thought to be involved in colour vision; but, are instead signalling brightness information.

## 2.4 THE VISUAL SYSTEM'S THALAMIC RELAY: THE LATERAL GENICULATE NUCLEUS

The lateral geniculate nucleus is part of a large number of brain nuclei located in the thalamus. It receives its inputs from the retina and is subdivided into six laminae in primates. From the dorsal surface, layers two, three and five receive information from the ipsilateral (same side) eye. Layers one, four and six get their inputs from the contralateral eye. Therefore, the structure is monocular.

Again, two opponent processes were identified reflecting the "relay" nature of this nucleus. In the absence of a stimulus (dark), the cells of this nucleus produce a steady (resting) rate of activity. In the presence of chromatic light they either increase or decrease their activity around the resting level. Some cells increase their activity for long wavelengths and decrease it for short wavelengths with peak activity roughly in the red part of the spectrum and maximum reduction roughly in the green. They are called +R,-G cells. Similarly, a mirror image cell activity pattern has been termed: -R,+G (DeValois et al., 1965). The other response pattern found in these investigations was +B,-Y and -B,+Y. The opponent coding seen in the retina has been preserved.

The mechanisms involved represent a balance between inhibition and excitation. Ex. +G,-R cells, when bleached with a strong red light show a reduction in the strength of inhibition of the

-R inhibitory mechanism and a release of the +G mechanism, with a much larger than normal “green” sensitivity.

Several response patterns, resembling known psychophysical phenomena, have been observed at this level. Opponent cells are not very sensitive to light intensity changes; but, they are sensitive to small changes in wavelength. A wavelength discrimination function, similar to the psychophysical function, has been described (DeValois, 1965).

Similarly, these cells show some change in response characteristics as a function of light intensity mimicking the Bezold-Brücke hue shift. At the crossover point from Green excitation to Red inhibition, the response is invariant as a function of intensity, as though the system was signalling a “unique” hue.

Little has been said about luminance to this point. It should be noted that there are cells that respond best to the luminance of a stimulus and are little concerned with the wavelength of the light as long as it's intense enough to be seen. Two response patterns have been noted +W(hite) or -(Black) and the inverse. That is, they increase their response rate over their response in the dark as a function of light intensity (+W) or they decrease their rate below the dark level in the presence of light (-B). The visual nervous system has kept luminance information and chromatic information separate at this stage of the nervous system.

## **2.5 THE VISUAL CORTICES: V1, V2, V3**

### **2.5.1 Spatial Responses**

Simple patches of light may be successfully used to stimulate retinal and LGN cells. Analysis of visual cortex suggests that these cells are involved in “feature extraction”. A brief description of pattern information processing is necessary in order to understand this level of coding.

Simple cells mimic the response of LGN cells and have concentric centre-surround organisation. They are receiving the information from the thalamic relay nucleus. The centre produces a response of inverse sign with respect to the surround. Some cells are excited by light in the centre and inhibited in the surround. An equal

number have the inverse response pattern. (Hubel, 1958; Hubel and Wiesel, 1968)

Complex cells respond to a bar of light oriented in a particular direction and of a specific width. These cells may respond best to movement in a specific direction. (Hubel, 1958; Hubel and Wiesel, 1968)

Hypercomplex cells have all the properties of complex cells with the addition of being sensitive to the length of the bar. (Hubel, 1958; Hubel and Wiesel, 1968)

### **2.5.2 Chromatic Responses: Oriented Cells**

Colour vision and pattern vision are often interconnected at this level of inspection. Simple cells are of two spatially chromatic sorts. For the first type, the centre may be +R,G while the surround is -R,+G. A second class of cells have a central strip responding to lights toward one end of the spectrum with two flanking areas (strips) responding to lights toward the spectral extreme. (Dow and Gouras, 1973)

Approximately one-half of complex and hypercomplex cells are colour coded. Two common sub-varieties exist. First “tuned” cells respond to different wavelengths but over a narrow range. A second category described as opponent are similar to LGN cells. They are excited or inhibited by long wavelengths and respond in the opposite manner to short wavelengths. (Dow and Gouras, 1973; Yates, 1974)

### **2.5.3 Non-Oriented Cells**

Many cortical cells are apparently not coding spatial information and have a poorly defined central response area that responds to light onset, offset or both. A concentric surround with a sluggish response profile, or no response has been described. (Dow and Gouras, 1973; Yates, 1974)

### **2.5.4 Non-Oriented Colour Cells**

Tuned cells respond over a very narrow wavelength range. (Dow and Gouras, 1973; Yates, 1974)

Opponent cells are excited or inhibited by short wavelengths and the reverse for long wavelengths. They have a single region of

activation in which the opponent systems are coextensive. (Gouras, 1974)

## 2.6 CORTICAL AREA V4

Recent work has involved investigation of a variety of other brain regions involved in processing chromatic information. Of particular interest is area V4 buried in the lunate sulcus. Initial evaluations indicate an extraordinary richness of colour sensitive cells, often with quite narrow wavelength tuning. More narrow chromatic response tuning has been seen in this brain region than in any other brain region. (Zeki, 1974, 1977, 1983a, 1983b)

## 2.7 SUMMARY

Two sorts of evidenced indicate fundamental trichromatic coding (Helmholtz) in the retina. Evidence from cone photopigment studies has shown trichromacy. Cone photoreceptor electrophysiology has provided confirmation of the above. However, within the retinal layers, coding shifts to opponent processes (Hering) and the code seems to stay that way for several ensuing neural stages.

At the thalamic relay, many aspects of hue analysis have taken place and analogues of colour experience are in place including:

- Chromatic adaptation - "fatigue-like phenomena"
- An analogue of the Bezold-Brücke hue shift including coding of unique hues
- Lateral inhibitory effects
- Wavelength discrimination
- Saturation determination
- Cortical receiving areas add pattern and other sorts of more sophisticated variables including:
  - The interaction of colour coding with pattern processing as well as colour coding in the absence of complex pattern information.
  - The reduction of broader band chromatic information into narrow band sensitivity ranges.
  - Extremely narrow band chromatic information coding in area V4.

## 2.8 OTHER ELECTRO-PHYSIOLOGICAL TECHNIQUES IN COLOUR VISION

The previous discussion has centred around information derived from microphysiological investigation and invasive techniques in animals. A great deal of work has been done with non-invasive techniques in both lower animals and humans. In particular, the non-invasive procedures have become quite common in clinical ophthalmology. The following discussion is presented with the hope that the reader will gain familiarity with other tools used in the discipline.

### 2.8.1 Electroretinography (ERG)

The ERG was first recorded in 1865 by Holmgren and it predates recording of the EKG and EEG. It did not become clinically useful until technical advances in amplification and other recording techniques improved. The first clinical study of the ERG was in 1945 by Karpe. Initially, researchers such as Granit (1947) showed three underlying processes which contributed to the massed summated potential known as the ERG. These processes were named based on the order in which they disappeared under ether anaesthesia or other substances. They were labelled as processes and given Roman numbers PI, PII, PIII.

The ERG is a voltage versus time representation of the electrical response of the eye to a sudden change in illumination. There is a simple nomenclature that is used with the recording.

The first component is labelled "A" and is the most negative value following a light flash. It is generated by hyperpolarisation of the photoreceptors after isomerisation of the photopigment housed in the membranes of the outer segment discs. For a variety of reasons, it is thought to be a photoreceptor response. (PIII)

The second component is labelled "B", which is the amplitude measured from the peak of the a-wave to the most positive peak that follows. It is the result of depolarisation of the Müller cells following an increase in extracellular retinal potassium (bipolar layer of the retina), after the receptor response; an inner nuclear layer response. (PII)



The third response labelled “C” is a long slow positive event (seldom used clinically in this form) that arises in the pigment epithelium and that is due to a hyperpolarisation of retinal pigment epithelial cells following a decrease in extracellular sub-retinal potassium after the receptor response. (PI)

### 2.8.2 Visual Evoked Response (VER)

The visual evoked response (VER) is a massed signal (derived from a large collection of cells operating in unison) derived from area 17 of visual cortex, predominantly from the macular projection. The signals are quite small (3-9 microvolts are “normal” for clinical VERs) and until the advent of signal averaging (a computerised technique to extract signals from noise) were only recordable from the brain surface. Hubel and Wiesel (1969) demonstrated that visual neurons respond selectively to visual patterns of progressively greater complexity at ascending levels in the hierarchy of cell layers within visual cortex. Most cortical neurons ignore uniform retinal illumination, but are selectively activated by contours and specific shapes.

Data from animal and human studies led to the utilisation of pattern reversal stimulation. Either stripes or checkerboards that alternate in counterphase are the most commonly used stimuli. The width of the stripes or the size of the checks may be varied to test spatial resolution with achromatic (usually black and white) stimuli.

The response amplitude of the VER is quite small and as previously mentioned requires signal averaging to appreciate. A series of positive-negative voltage sequences is elicited and they are usually labelled by their time of occurrence or by their order of appearance and polarity. For example, the potential of greatest interest for visual purposes is labelled P100 because it occurs around 100 milliseconds after a pattern reversal or it may be labelled P2 since it is the second positive peak in a string of negative, positive voltages. It has the greatest test-retest reliability of the ensemble and the greatest inter-individual correlation. P2 is highly correlated with pattern processing, such that its amplitude and latency (to peak) are influenced by even small changes in the focus of the eye. It is age related. Since neural conduction velocity decreases as age increases, the VER latency changes, especially after age 45. It is

widely used in clinical ophthalmology and neurology since it is sensitive to inadequate myelin regeneration, axonal dystrophy, decreased numbers of retinal ganglion cells and changes in neurotransmitter function.

Thirty years of colour vision physiology has resulted in remarkable elaboration of the substrates of the colour vision experience. It is safe to say, however, that the system has by no means given up more than a few of its secrets.

## 2.9 REFERENCES

1. DeValois, R.L., Smith, C.J., Katai, S.T. and Karoly, S.J., Responses of single cells in different layers of the primate lateral geniculate nucleus to monochromatic light, *Science*, 1958, pp 238-239.
2. Devalois, R.L., Behavioral and electrophysiological studies of primate vision. In Neff, W.D. (Ed.) “Contributions to sensory physiology: V1” (1965), New York, Academic Press.
3. Dow, B.M. and Gouras, P., Color and spatial specificity of single units in *Rhesus* monkey foveal striate cortex, *Journal of Neurophysiology*, 1973, 36, pp 79-100.
4. Gouras, P., Identification of cone mechanisms in monkey ganglion cells, *Journal of Physiology*, 1968, 199, pp 533-547.
5. Gouras, P., Opponent-color cells in different layers of foveal striate cortex, *Journal of Physiology*, 1974, 238, pp 583-602.
6. Granit, R., Sensory mechanisms of the retina. 1947 London: Cambridge Univ. Press, (Reprinted in 1963 by Hafner Publishing Co., New York).
7. Holmgren, F., Method att objectivera effecten av ljusintyck på retina. *Uppsala Läkaref. förh.*, 1, pp 177-191, pp 1865-1866.
8. Hubel, D.H., Cortical unit responses to visual stimuli in non-anaesthetised cats, *American Journal of Ophthalmology*, 1958, 46, pp 110-121.

9. Hubel, D.H. and Wiesel, T.N., Receptive fields and functional architecture of monkey striate cortex, *Journal of Physiology London*, 1969, 195, pp 215-243.
10. Karpe, G., The basis of clinical electroretinography, *Acta Ophthalmology*, (Copenhagen) Suppl. 24, pp 1-118, 1945.
11. MacNichol, E.F. Jr. and Svaetichin, G., Electric responses from the isolated retinas of fishes, *American Journal of Ophthalmology*, 1958, 46 No. 3 Part II, pp 26-40.
12. Marks, W.B., Dobelle, W.H. and MacNichol, E.F., Visual pigments of single primate cones, *Science*, 1964, 143, pp 1181-1183.
13. Penn, R.D. and Hagins, W.A., Signal transmission along retinal rods and the origin of the electroretinographic a-wave, *Nature*, 1969, 223, pp 201-205.
14. Rushton, W.A.H., A cone pigment in the protanope, *Journal of Physiology*, 1963, 168, pp 345-359.
15. Rushton, W.A.H., A foveal pigment in the deuteranope, *Journal Physiology*, 1965, 176, p 2437.
16. Rushton, W.A.H. and Henry, G.H., Bleaching and regeneration of cone pigments in man, *Vision Research*, 1968, 8, pp 617-631.
17. Sholl, D.A., The organisation of the cerebral cortex, 1956, Methuen, London.
18. Svaetichin, G., Spectral response curves from single cones, *Acta Physiology Scandinavian Supplement 34*, 1953, 39, pp 17-46.
19. Tomita, T., Electrophysiological study of the mechanisms subserving color coding in the fish retina, *Cold Spring Harbor Symposia on Quantitative Biology*, 1965, 30, pp 559-566.
20. Yates, J.T., Chromatic information processing in the foveal projection (*area striata*) of un-anaesthetised primate, *Vision Research*, 1974, 14, pp 163-173.
21. Zeki, S., The mosaic organisation of the visual cortex in the monkey. In Bellairs, R. and Gray, E.G. (Eds), *Essays on the Nervous System*, 1974, Oxford: Clarendon Press.
22. Zeki, S., Color coding in the superior temporal sulcus of rhesus monkey visual cortex, *Proc. roy. Soc. B.*, 1977, 197, pp 195-223.
23. Zeki, S., Color coding in the cerebral cortex: the reaction of cells in monkey visual cortex to wavelengths and colors, *Neuroscience*, 1983, 9, pp 741-765.
24. Zeki, S., Color coding in the cerebral cortex: the responses of wavelength-selective and color coded cells in monkey visual cortex to changes in wavelength composition, *Neuroscience*, 1983, 9, pp 767-781.

## Chapter 3

### Recent Progress in Colour Vision

Jan Walraven

This literature study on recent advances in colour vision focuses on the spectral filtering and trichromatic processing of the visual stimulus, still the most relevant issue for practical purposes, such as testing for colour deficiencies and the definition of the so-called “CIE standard observer”.

The following topics are addressed:

- new data on the spectral sensitivity functions of the L(ong-wave), M(iddle-wave) and S(hort-wave) photoreceptors;
- the integration of revised data on spectral filtering in the eye media (lens and macula pigment), taking into consideration modifying factors like age, stimulus size and pupil diameter;
- recent developments in molecular genetics on the variability of the absorption spectra of the L and M pigments;
- a simulator that allows the visualisation of any form of deficient colour vision;
- recent developments in colour constancy;
- a cursory introduction to colour processing beyond the retina.

#### 3.1 INTRODUCTION

Although a discussion of the recent progress in the science of colour vision is not quite possible without considering the advances in the understanding of the visual system as a *whole*, we will nevertheless focus on just the colour aspect. It has to be kept in mind though, that the perception of colour not only depends on the spectral, but also the *spatial* and *temporal* properties of the visual stimulus. For example, good colour discrimination requires a certain minimal size (angular subtense  $> 15$  minutes of arc) and duration ( $> 150$  ms) of the light stimulus entering the eye. This is particularly true for the discrimination of lights that require differential stimulation of the blue sensitive photoreceptors (S-cones). As reviewed elsewhere (Walraven, 1985), the underlying cause of this phenomenon is the sparse distribution of the S-cones in the retina (e.g. De Monasterio et al.,

1985). To compensate for this scarcity, the blue system boosts its output by spatial and temporal integration of the incident stimulus light, and thus becomes less efficient when the stimulus is reduced in size and/or duration.

The human eye performs a rough spectral analysis on the light entering the eye. Any spectral distribution is reduced to a code of just three numbers, the well-known principle of trichromacy. These numbers relate to the (weighted) outputs of the three classes of photoreceptors that are embedded in the retina. In order to predict the visual response to a light stimulus one should be able to derive the transducer function that relates physical input (effective quantum catch) to visual output (perception). That output, the response to a signal that starts as an analogue signal (graded potential) at the receptor level and terminates as a train of ramified electrical pulses (spikes) in the visual cortex of the brain, is still far from predictable.

Even for the case of a small spot of light centred on the fovea, it is not a simple matter to predict what the visual response (sensation) will be as a function of its physical parameters. Nonetheless, much progress has been made in the understanding of the mechanisms underlying the colour response, in particular with respect to the physiological variables relating to the eye of the so-called “CIE Standard Observer”.

#### 3.2 NEW STANDARD FOR CONE SPECTRAL SENSITIVITIES

One of the main issues in the field of colour vision was, and still is, the determination of the spectral sensitivities of the photoreceptors. There are two different types: the rods (so called because of their cylindrical form), the receptors that subserve night vision, and three classes of cones (so called because of their tapered form), which are only active during the daytime. Although the rods outnumber the cones by a factor of 60 to 1, they are of little relevance for colour vision. At night they can only produce a luminance signal, whereas during the daytime they are effectively silenced because

of reaching their response maximum (rod saturation). Still, at mesopic light levels (twilight and dusk), where rods start to take over from the cones (or vice versa), rods and cones can interact, causing desaturation of the colour stimulus (e.g., Trezona, 1976).

The photopigments of the “colour receptors”, three classes of cones, are (broadly) tuned to different spectral ranges. These roughly correspond to the blue, green and red parts of the spectrum, and have for a long time been labelled therefore, as the “blue”, “red”, and “green” cones. In the modern, although still not generally accepted nomenclature, the classes of cones are referred to as short-wave (S), middle-wave (M), and long-wave (L) cones.

### 3.2.1 Cone Fundamentals

One of the first well-documented sets of cone spectral sensitivities (Vos & Walraven, 1971; Vos, 1978), normalised for equal sensitivity at equal-energy white (Walraven & Werner, 1991) is shown in Figure 3.1.

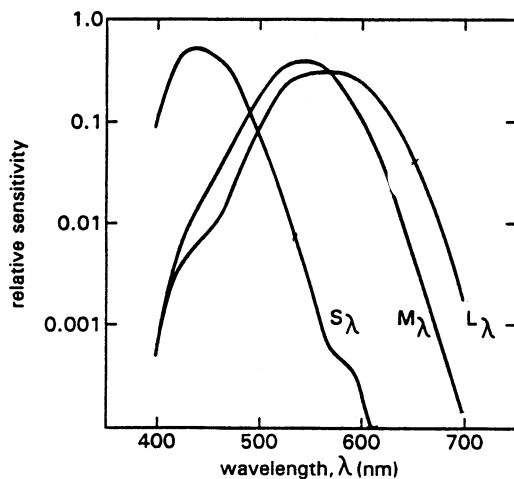

Figure 3.1: Spectral sensitivities,  $S_\lambda$ ,  $M_\lambda$  and  $L_\lambda$  of human cones (Vos, 1978), normalised for equal sensitivity at equal-energy white (Werner & Walraven, 1984).

The cone spectral sensitivities (or cone fundamentals) shown in Figure 3.1 are hardly different from those derived in other studies, like those of Smith and Pokorny (1972, 1975) and Estévez (1979). They are different enough, however, to necessitate a final version, based on both old and very recent research efforts (Stockman et al., 1993). These new standards are now in the stage of fine tuning by the technical committee TC 1-36 of the CIE (Commission

Internationale de l’Eclairage), and will become available in 1997.

### 3.2.2 Interocular Media

The search for standardised cone fundamentals is difficult. It not only requires knowledge about the spectral absorption of the three photopigments, but also about the spectral filtering due to the eye media (macular pigment, lens and anterior ocular media). One of the better attempts to describe the relative density spectrum of the macular pigment, is that of Stiles and Wyszecki (1967), but Bone et al. (1992) have provided data for even further improvements, and pointed out that their results can be excellently described by a template derived by Vos (1972).

The absorption due the second component of the ocular media, the lens and anterior ocular media, strongly affects the light absorption in the short-wave part of the spectrum. Here too, the standardisation efforts of TC 1-36 have already paid off. It is to be expected that there will be a strong preference for an optical density function of the type proposed by Van Norren and Vos (1974) and Stockman et al. (1993), as shown in Figure 3.3.

There can be little doubt that the data on the spectral absorption in the ocular media can be well described by the functions shown in Figures 3.2 and 3.3. It should be kept in mind though, that these functions depend on age and retinal location (field size). The effect of these variables is reasonably well known however, and will be incorporated in the final modelling of the set of the standard cone spectral sensitivities (CIE, 1995).

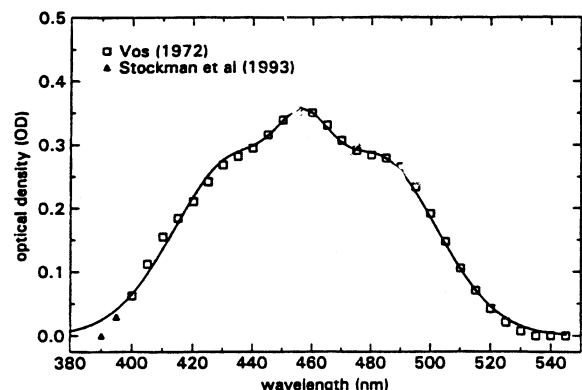
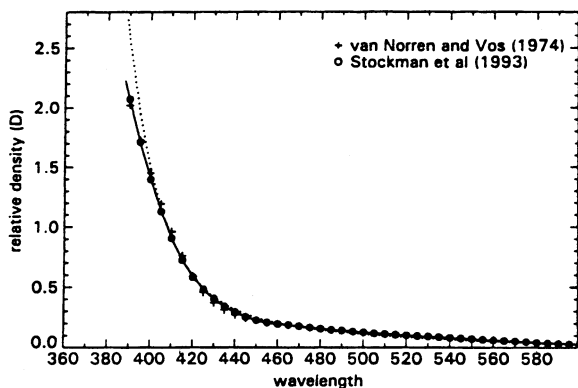

Figure 3.2: Optical density spectrum of human macular pigment according to Vos (1972). The data are fitted by an analytical function (CIE, 1995).



**Figure 3.3: The relative optical density spectrum of lens and anterior ocular media, according to Van Norren and Vos (1974) and Stockman et al. (1993). The data are fitted by an analytical function (CIE, 1995).**

### 3.2.3 Cone Pigments

The spectral characteristics of the cone pigments are not just replica of a particular choice of the spectral absorption of the photopigments. The point is that this choice also depends on assumptions regarding the optical density of the pigment. The optical density varies with the length of the receptors (the longer the receptors the higher the optical density), and since the length of the cones progressively decreases when going from the central part of the retina (fovea centralis) to the periphery, the optical density follows suit. This implies that the extent to which a stimulus covers the retina has an effect on the corresponding spectral analysis by the cones. There have been quite a number of studies that relate to this problem, which all show that this indeed to be the case. On the basis of the available data and analyses (e.g., Elsner et al., 1993; Stockmann et al., 1993; CIE, 1995), one may estimate, for example, that the optical density for a 2° and 10° field corresponds to 0.4 and 0.2, respectively.

The most important determinant of the cone spectral sensitivity of the cones still is, of course the spectral absorption of the photopigment in question (for a given optical density). Many studies have been dedicated to derive the cone pigment absorption spectra, thereby using a variety of techniques, of which the most recent one is the recording of photocurrents from single receptors (Baylor et al., 1984; Schnapf et al., 1987). The results are very close to the estimates based on psychophysical techniques, and it will not be long until at least this chapter of visual science, the

accurate description of the cone action spectra, will be completed. Right now there is already sufficient information available to justify the attempt of the CIE to define the cone spectral sensitivities of a standard observer (both a 2° and 10° field), a project that may be expected to be finished in 1997.

### 3.2.4 Molecular Genetics of Cone Pigments

Recently, great progress has been made in the molecular genetics of cone pigments, that is, the DNA sites and mechanisms that govern the building of photopigments (e.g., Nathans et al., 1992; Neitz et al., 1991). There are still many problems to be solved, like for example, how to establish the link with gene-expression, the manifestation of certain (X-linked) genes in the phenotype. Psychophysical methods for establishing what the findings in molecular genetics imply for the machinery of the visual system are still in a developmental stage.

It appears that there are individual variations in both normal and anomalous L and M cone pigments (Neitz & Jacobs, 1990; Merbs & Nathans, 1992). For the moment only the differences in spectral tuning will be considered, as indicated by  $\lambda_{\max}$ , the wavelength at which absorption is maximal. For the normal pigments one can discriminate between a single M pigment, peaking at 530 nm, and two different L pigments, peaking at about 552 or 557 nm, and probably distributed about equally over the population. According to Merbs and Nathans (1992) the anomalous pigments may result from gene recombinations of the “real” L and M pigments, producing at least 9 different anomalous pigments with intermediate values of  $\lambda_{\max}$ , maximally shifted by about 6 nm to either shorter wavelengths (for the L pigment), or longer wavelengths (for the M pigment).

Traditionally, it has always been assumed that the anomalous pigments are different from the normal pigments, but there is now quite some evidence suggesting that the pigments of both the colour defective and the normal eye draw from the same two sets of M and L pigments (Neitz et al., 1993), an idea already put forward by Alpern and Moeller (1977). Normal colour vision would, according to this view, only differ from anomalous colour vision in that one or more pigments are drawn from *both* the L and M pigment pools, whereas anomalous vision is subserved by two (or more) pigments

drawn from a *single* set of either M or L pigments. As shown in the study of Merbs and Nathans (1992) there may be quite a variety of L and M pigments<sup>1</sup>. This could also explain the large variability in Rayleigh match settings of people classified as having normal colour vision. Still, most of that variability can be explained by just two major subtypes of L and M cone pigments, which probably reflects the well-established substitutions of the proteins serine and alanine at DNA location 180 of the pigment gene (Neitz et al., 1993).

According to the new insights derived from the molecular genetics of the L and M pigments, anomalous colour vision results from the loss of one pigment type (L or M), but is nevertheless trichromatic because more than one pigment is available from the remaining pigment type. However, since the two pigments are drawn from the same subset their absorption functions will be nearly overlapping, so colour discrimination will be relatively poor. In the case of dichromatic vision, there is only one pigment (or two identical ones) available from the subset, resulting in a still further deterioration of colour discrimination.

### 3.3 DEFECTIVE COLOUR VISION

#### 3.3.1 New Prospects?

As pointed out above, recent developments in the field of monocular genetics hold promise in unravelling the underlying mechanisms involved, in particular as it comes to understanding the incidence and variability in cone photopigments. The old classification in dichromats and anomalous trichromats is still largely sustained, but within the various classes there are further subdivisions possible. It will take some time however, before we can expect this knowledge to come to expression in the fields of selection and application.

At present the contribution of modern colour science to the problems caused by defective colour vision are not impressive. The anomaloscope is still the most basic way of analysing a (red-green) colour disorder, even if there have been attempts to provide for new instruments, like the OSCAR, or the Medmont C-100 that might be used as

replacements (cf. Cole, 1991). There clearly is a demand for new tests that provide for better discrimination and gradation of the various types of colour vision deficiency. A first step in that direction would be to make use of the recent knowledge of the normal and anomalous photopigments, as collected by CIE TC 1-36. That information can be used for the specification of more accurate pseudo-isochromatic test stimuli (not necessarily test plates). A first step in that direction has been made at the TNO Institute for Human Factors Research (Walraven & Alferdinck, 1995), as will be discussed below.

#### 3.3.2 Visualisation of Colour Deficient Vision

Given the specification of a stimulus in CIE XYZ space, it is possible to transform that stimulus into units of LMS cone space and then determine the effect of reducing the LMS space to the cone space of a dichromat (LS, MS or LM). It is thereby assumed that the two cone pigments of the dichromat are not different from those of the normal eye, the old hypothesis of König and Dieterici (1886). A recent demonstration of how dichromatic colour vision may thus be visualised has been reported by Viénot and Mollon (1995), thereby using a colourimetric approach, which amounts to the projection of chromaticity loci in x,y space onto a single blue-yellow colour axis. However, this method can only handle dichromatic colour vision.

A more general approach, which can also be applied to anomalous trichromatism (the more common affliction) was developed by Walraven and Alferdinck (1995, 1997). The principle has been worked out for the colours shown on a CRT colour monitor, but can be applied to any other medium with known spectral emission or reflectance spectra of the primaries used for generating the colours. The algorithm can be applied to any form of deficient colour vision, provided the spectral sensitivities of the cones and ocular media are known.

Although that information is still not completely secured, one can make reasonable assumptions for each of the various types of deficient colour vision (e.g., DeMarco et al., 1992). Conversely, having now the means to generate colours that are confused for a given type of deviant spectral “make-up” of the cones, one can easily make the corresponding test plates for detecting such colour deficiencies.

<sup>1</sup> This does not apply to the short-wave system, which has a quite different evolutionary origin (Jacobs, 1981). Whereas the photopigments of the L and M cones are encoded by an array of genes on the X-chromosome, the pigment of the S cone is shaped by a single gene (on chromosome 7).

Due to the still increasing use of colour-coded information displays, an increasing number of people with defective colour vision will be confronted with their handicap. It is for that reason that the aforementioned algorithm for simulating deficient colour vision was developed. It enables a display designer to visualise how the displayed colours appear to the colour deficient eye. It is in principle possible, then, to adjust the colour specifications to the specific needs of the user. This is illustrated in Figure 3.4.

In the example shown in Figure 3.4, the problem for the colour deficient eye is the reduced discriminability of the secondary road system. In this case the remedy is quite simple, that is

replace orange by dark red for colour coding. The main benefit of the visualisation tool is that one can immediately see which trouble spots are to be expected for the colour deficient user of the display. In this particular example, the colour adjustment can even restore the legibility for the dichromatic eye. In practice however, this may well be a too problematic group, and one should rather concentrate on the much larger population of anomalous trichromats. Work is in progress to develop an expert system that tests and diagnoses the colour discrimination of the user, after which the computer suggests the appropriate modifications for the colour table of the application in question.



**Figure 3.4: A map display, as seen by the normal trichomat (left), a deuteranomalous trichomat (middle) and a deuteranope (right). Upper row: original map, showing the gradual disappearance of the (orange) secondary roads with increasing deficiency (from anomalous to dichromatic). Bottom row: slightly adjusted map (orange replaced by dark red), showing the improved visibility of the road structure, both for dichromatic and anomalous colour vision.**

## 3.4 COLOUR IN CONTEXT

### 3.4.1 Chromatic Induction

Colour perception is not always predictable on the basis of the spectral composition of the stimulus in question. The perceived hue of a stimulus may change drastically under the influence of other colours in the field of view. In general the change will be in the direction of a colour complementary to the one causing the induction effect. Chromatic induction, a collective name for the effects produced by simultaneous contrast, successive contrast and chromatic adaptation (cf. Walraven, 1976), can be described by a relatively simple model of colour processing (Walraven, 1981; Werner & Walraven, 1982). Such models are still too limited, however, to deal with scenes that are more complex than the typical centre-surround configuration of the laboratory test and inducing stimulus.

Chromatic induction can be a problem for colour-coded displays, because colours may look different depending on the colour of surrounding colours. For example, green-coloured symbols may appear quite yellowish when surrounded by a blue background. Much depends on the luminance contrast between colours (orange may turn brown on a bright white background), so one should always specify both the chromaticity *and* luminance of colours to be used for colour-coded information displays.

### 3.4.2 Colour Constancy

Colour constancy is the ability of the visual system to perceive object colours as fairly stable, despite the changes in colour that are introduced by changes in the colour of the ambient illumination. It can be argued that chromatic induction is actually an “artefact” related to a misapplication of the mechanism of colour constancy (Walraven, Beneschawel & Rogowitz, 1987). That is, the colour of the surrounding inducing stimulus is interpreted by the visual system as representing the colour of the illuminant, resulting in a suppression of that colour in the test field.

A new development in visual science is the so-called computational vision model. According to such models colour constancy can be explained by assuming that the visual system is capable of recovering the spectral information that is lost in the process of light absorption in the photopigments of the eye (e.g., Maloney &

Wandell, 1986). More precisely, the visual system should be able to decompose the light received from a colour stimulus into its two constituent spectral distributions, i.e. that of the illuminant and the surface reflection in question. The rationale behind this approach is that both the illuminant and surface spectra can be reasonably well described by three spectral basis functions (within the spectral window of 400–700 nm). Given an estimate of the chromaticity (x,y coordinates) of the illuminant, the reconstruction of (invariant) surface reflection is possible, which is essentially what colour constancy is all about. However, in the one study that actually tested this hypothesis it could be shown that a much less complicated trichromatic approach, based on the processing of cone-specific contrast, actually out-performs such computational models as it comes to predicting what human observers actually see (Lucassen & Walraven, 1996). This result warns against a too quick acceptance of such computational models for predicting the human visual response.

## 3.5 COLOUR PROCESSING BEYOND THE RETINA

Colour research covers many aspects that have not been discussed in this chapter. For example, colour (as opposed to luminance) may turn out to be completely incapable of supporting visual functions like accommodation, motion perception and stereopsis. This implies that in displays in which colour-coded information causes degradation of luminance contrast, all of these functions may be severely jeopardised.

The results from many physiological and psychophysical studies indicate that the visual system processes colour and luminance along different pathways, generally referred to as the parvocellular (small-celled) and magnocellular (large-celled) layers in the lateral geniculate body, a visual relay station in the midbrain (e.g., Livingstone & Hubel, 1984). Roughly speaking, it appears that the parvocellular pathway is mainly involved in colour and spatial information transmission (at the expense of temporal resolution), whereas the opposite, i.e. luminance and temporal information discrimination (at the expense of spatial resolution), applies to the magnocellular pathway.

At the cortical level the two aforementioned pathways are still in evidence, but in addition further ramifications occur into various layered areas. The parvocellular (colour) pathway passes



from the primary cortex (V1) through the secondary visual cortex (V2, V3, V4) to the infero-temporal cortex (IT), which subserves the more complex visual functions, like attention, discrimination and memory. This is as much as can be treated within the scope of this chapter. For a more extensive, although still very abbreviated introduction to colour processing beyond the retina, the reader is referred to a comprehensive review by Snyder and Trejo (1992).

### 3.6 CONCLUDING REMARKS

The science of (colour) vision has progressed rapidly over the past twenty years, resulting in the first hesitant steps to build a “silicon retina” and even an “eye prosthesis”. However, the off-spin for the operational use in aviation may seem rather distant.

On the other hand, due to the increasing use of colour for information coding in the cockpit, air traffic control and other aviation related environments (maintenance, simulators etc.), there is a growing need for better standards and general colour expertise. So, even if application of the results from the frontiers of colour science may have to await future developments (like machine vision), the more down-to-earth attempts at defining the standard eye (both with normal and deficient colour vision) will already pay off in many applications that require valid colour standards.

### 3.7 REFERENCES

- Alpern, M. and Moeller, J. (1977), The red and green cone visual pigments of deuteranomalous trichromacy, *Journal of Physiology*, 266, pp 647-675.
- Baylor, D.N., Nunn, B.J. and Schnapf, J.L. (1984), The photocurrent, noise and spectral sensitivity of the cones of the monkey macaca fascicularis, *Journal of Physiology*, 390, pp 145-160.
- Bone, R.A., Landrum, J.T. and Cairns, A. (1992), Optical density spectra of macular pigment *in vivo* and *in vitro*, *Vision Research*, 32, pp 105-110.
- CIE (1995), *Fundamental chromaticity diagram with physiological axes* (Draft 7) (TC 1-36), Vienna, Austria: Commission Internationale de l’Eclairage.
- Cole, B.L. (1992), Does defective color vision really matter, *Proceedings of the IRGC Conference* (1991), Sydney, Australia.
- DeMarco, P., Pokorny, J. and Smith, V.C. (1992), Full-spectrum cone sensitivity functions for X-chromosome-linked anomalous trichromats, *Journal of the Optical Society of America*, A 9, pp 1465-1476.
- DeMonasterio, F.M., McCrane, J.K., Newlander, J.K. and Schein, S.J. (1985), Density profile of blue-sensitive cones along the horizontal meridian of Macaque retina, *Investigative Ophthalmology and Visual Science*, 26, pp 289-302.
- Elsner, A.E., Burns, S.A. and Webb, R.H. (1993), Mapping cone photopigment density, *Journal of the Optical Society of America*, A 10, pp 52-58.
- Estévez, O. (1979), *On the fundamental data base of normal and dichromatic vision*, Thesis University of Amsterdam.
- Jacobs, G.H. (1981), *Comparative color vision*. New York: Academic Press.
- König, A. and Dieterici, C. (1886), Die Grundempfindungen und ihre Intensitäts-Verteilung im Spectrum, *Sitzungen der Akademischen Wissenschaften*, pp 805-829, Berlin.
- Livingstone, M.S. and Hubel, D.H. (1984), Anatomy and physiology of a color system in the primate visual cortex, *Journal of Neuroscience*, 4, pp 309-356.
- Lucassen, M.P. and Walraven, J. (1996), Color constancy under natural and artificial illumination, *Vision Research*, 37, pp 2699-2711.
- Maloney, L.T. and Wandell, B.A. (1986), Color constancy; a method for recovering surface spectral reflectance, *Journal of the Optical Society of America*, A 3, pp 29-33.
- Merbs, S.L. and Nathans, J. (1992), Absorption spectra of the hybrid pigments responsible for anomalous color vision, *Science*, 258, pp 464-466.

16. Nathans, J., Merbs, S.L., Sung, C-H., Weitz, C.J. and Wang, Y. (1992), Molecular genetics of human visual pigments, *Annual Review of Genetics*, 26, pp 403-424.
17. Neitz, J. and Jacobs, G.H. (1990), Polymorphism in normal human color vision and its mechanism, *Vision Research*, 30, pp 620-636.
18. Neitz, M., Neitz, J. and Jacobs, G.H. (1991), Spectral tuning of pigments underlying red-green color vision, *Science*, 252, pp 971-974.
19. Neitz, M., Neitz, J. and Jacobs, G.H. (1993), More than three different cone pigments among people with normal color vision, *Vision Research*, 33, pp 117-122.
20. Schnapf, J.L., Kraft, T.W. and Baylor, D.A. (1987), Spectral sensitivity of human cone photoreceptors, *Nature*, 325, pp 439-441.
21. Smith, V.C. and Pokorny, J. (1972), Spectral sensitivity of color blind observers and the cone pigments, *Vision Research*, C 12, pp 2059-2071.
22. Smith, V.C. and Pokorny, J. (1975), Spectral sensitivity of the foveal cone photopigments between 400 and 500 nm, *Vision Research*, 15, pp 161-171.
23. Snyder, H.L. and Trejo, L.J. (1992), Research methods, In H. Widdle & D.L. Post (Eds.), *Colour in electronic displays*. New York: Plenum Press.
24. Stockman, A., MacLeod, D.I.A. and Johnson, N.E. (1993), Spectral sensitivities of the human cones, *Journal of the Optical Society of America*, A 10, pp 2491-2521.
25. Trezona, P.W. (1976), The tetrachromatic color match as a colorimetric technique, *Vision Research*, 13, pp 9-25.
26. Van Norren, D. and Vos, J.J. (1974), Spectral transmission of the ocular media, *Vision Research*, 15, pp 749-751.
27. Viénot, F. and Mollon, J.D. (1995), What do color blind people see?, *Nature*, 376, pp 127-128.
28. Vos, J.J. (1972), Literature review of human macular absorption in the visible and its consequences for the cone receptor primaries, *Report TNO-IZF 1972-17*. Soesterberg, The Netherlands: TNO Institute for Perception.
29. Vos, J.J. (1978), Colorimetric properties of a 2° fundamental observer, *Color Research and Application*, 3, pp 125-128.
30. Vos, J.J. and Walraven, J. (1971), On the derivation of the foveal receptor primaries, *Vision Research*, 11, pp 799-818.
31. Walraven, J. (1976), Discounting the background, the missing link in the explanation of chromatic induction, *Vision Research*, 16, pp 289-295.
32. Walraven, J. (1981), Perceived color under conditions of chromatic adaptation; evidence for gain control by  $\pi$ -mechanisms, *Vision Research*, 21, pp 611-620.
33. Walraven, J. (1985), The colors are not on the display: a survey of non-veridical perceptions that may turn up on a color display, *Displays*, 6, pp 35-42.
34. Walraven, J. (1987), *Color coding for ATC displays* (EEC Report 212), Brussels: Eurocontrol.
35. Walraven, J. and Werner, J.S. (1991), The invariance of unique white: possible implications for normalizing cone action spectra, *Vision Research*, 31, pp 2185-2193.
36. Walraven, J. Benzschawel, T. and Rogowitz, B.R. (1987), Color constancy interpretation of chromatic induction, In M. Richter (Ed., 1989), *AIC Proceedings "Stiles-Wyszecki Memorial Symposium on color Vision models"*, pp 269-273, Göttingen, BRD: Muster-Schmidt Verlag.
37. Walraven, J. (1992), Color basics for the display designer, In H. Widdle & D.L. Post (Eds.), *Color in electronic displays*. New York: Plenum Press.
38. Walraven, J. and Alferdinck, J.W.A.M. (1995), Simulation of defective color vision, *Memo TNO-TM 1995-M8* (In Dutch), Soesterberg, The Netherlands: TNO Human Factors Research Institute.

39. Walraven, J. and Alferdinck, J.W.A.M. (1997), Color displays for the color blind, *Proceedings of the fifth IS&T/SD Color Imaging Conference: Color science, Systems and Applications*, pp 17-23, November 17-20, Scottsdale, Arizona.
40. Werner, J.S. and Walraven, J. (1982), Effect of chromatic adaptation on the achromatic locus; the role of contrast, luminance and background color, *Vision Research*, 22, pp 929-949.
41. Wyszecki, G. and Stiles, W.S. (1967), *Color Science*, John Wiley and Sons, New York.

**This page has been deliberately left blank**



**Page intentionnellement blanche**

## Chapter 4

### Colour Vision Testing – Methodologies: Update and Review

#### The Basis of Colour Vision Testing - Hereditary Defects

J. Terry Yates and Marie-France Heikens

Three basic methodologies have been used to evaluate colour vision. We will, in considerable detail, describe those methods, provide evaluations of existing tests and discuss strategies for screening and diagnosing hereditary and acquired defects in colour vision.

#### Colour Confusion

Individuals with severe colour vision defects (dichromats - see below) confuse “colours”. Protanopes confuse certain greens and red. Deuteranopes confuse other greens and purple. The locations of the confusions have been empirically determined and plotted in colour space. Isoconfusion lines are known and represent a spectrum of confusion colours. In particular, the information is well specified for “red-green” dichromats.

Simply put, any colour on the confusion line may be confused with any other colour on the line. This leads, for example to the seeming incongruity of “red” being thought to be green by protanopes; that is, they are profoundly confused. Isochromatic plate tests, the Dichotomous Panel-15 (D-15) test and the Lanthony desaturated D-15 test, among others, utilise confusability of “colours” to identify moderate to severe red-green colour defectives.

#### Brightness Naming, Another Form of Confusion

Other tests, exemplified, by the Farnsworth lantern use brightness misidentification as their basis. Since most red-green colour defectives see yellow - blue, little or no red and green and to a greater or lesser extent shades of grey, they learn to name colours based on brightness. In severe cases, equiluminant red appears to be grey and equiluminant green appears to be white. By the simple rubric of reducing the intensity of a “green” light, it will appear grey and be called out as “red”.

Of course, no red can possibly be seen; but the well-established naming of colours based on brightness in these individuals pervades.

#### Hue Discrimination

The last commonly used test, the FM-100, is also attributable to Farnsworth. A series of “bottle” caps housing a chip made from Munsell papers have been selected so that they are all equally bright and their separation in colour appearance is equidistant. Of extreme importance, is the separation of the continuum (colour circle) into four trays of chips (each representing roughly one quadrant of the colour circle). No confusion colours exist in any one of the trays. The result is that the test evaluates hue discrimination; the ability to judge stimuli of similar wavelength and of equal brightness as different in hue and to order them from one spectral extreme to the other.

### 4.1 SPECIFICATION OF COLOURS

It is important to understand two of the possible ways that colours are produced. One may mix lights or mix pigments. The former combine by addition and latter by subtraction. Red light and green light will add to produce white or yellow depending on the “red” and “green” selected. Light directed at a combination of pigments will interact by subtraction. The results are complex and depend on which pigments are involved and the illuminant.

Fundamental to all of colour vision is the principle of metamerism which depends on additivity of light. A red of 670 nm and a green of 545 nm when added in equal amounts will produce a yellow of 589 nm that will perfectly match a pure yellow reference field, as long as the luminance of the two half fields is identical.

There are some laws that govern the way chromatic lights are perceived.

1. If the same luminance is added to the colour mixture field and the yellow reference field, the metamerism is unchanged. The system is additive.
2. If the luminance of both fields is changed by the same amount, by adding more light to both, metamerism holds. The system has scalar properties.
3. A metamer may be exchanged for a spectral colour that it matches and the matching field that results may be substituted for any other match that contains the spectral colour. The system is associative.

Simply put, a colour match is invariant for a wide variety of conditions. A metameric white will appear reddish after the eye is exposed to bright green light as will the white to which it is a metamer.

## 4.2 METAMERS AND COLOUR VISION

The importance of these observations helps to define the nature of colour vision. A metamer may be found for any spectral hue (such as those found in a rainbow) if there are three primaries making up the metamer. Helmholtz wisely observed that two primaries are not enough, and three are too many. This deduction was made in the absence of any “wet” physiological data. Validation didn’t come from such data until it was collected decades later.

Usually a red, green and blue are used to build a metamer (where no two of the hues may be mixed to make the third hue).

Three basic sorts of hereditary colour vision may occur in humans:

1. Normal trichromacy - all spectral hues are capable of being matched with **intensity** ratios of the three primaries.
2. Anomalous trichromacy - three hues are needed, but one of the primaries must be more intense - a colour weakness.
  - protanomaly - red weak
  - deuteranomaly - green weak
  - tritanomaly - blue weak

3. Dichromacy - only two primaries are needed to match any spectral hue. The match, of course, is quite unacceptable to normals since it is made based on brightness and not on the basis of hue appearance.

- protanopia - severe red-green defect
- deuteranopia - severe red-green defect
- tritanopia - (rare) severe blue-yellow defect

## 4.3 HEREDITARY COLOUR VISION DEFECTS

### DEFECTS INHERITANCE INCIDENCE

#### RED-GREEN

Protanopia	X-L
Deuteranopia	X-L
Protanomaly	X-L
Deuteranomaly	X-L

#### BLUE-YELLOW

Tritan (tritanopic and incomplete tritanopia)	AD
---	----

AD = autosomal dominant

X-L = X linked

## 4.4 TESTING THEORY/ METHODOLOGY

**NB: throughout this document, tests of validity and reliability depend on the K statistic (Bishop et al., 1975). Comparisons are made with respect to the Nagel Model I anomaloscope. Perfect agreement results in a score of 1.0, and no agreement a score of 0.0.**

### 4.4.1 Review of Common Test Devices

1. Design premise/theory
  - a. **The Nagel anomaloscope** is the gold standard. It depends on the Rayleigh equation where normals may match pure yellow (589 nm) with a mixture of pure red (670 nm) and green (545 nm). Anomalous observers require more red in the mixture (protanomaly) or more green (deuteranomaly). Dichromats (protanopes or deuteranopes) will accept a wide range of red green mixtures to match yellow because they are matching brightness,

not colour. There are two existing versions of the Nagel anomaloscope: Nagel I and Nagel II. The Nagel I is still available and is recommended. The Nagel II is no longer in production.

Advantages: test has a long and hallowed history that is well respected.

Disadvantages: expensive instrument that requires an experienced examiner's skills.

Validity: validation measures of other colour vision tests are based on this instrument.

Maintenance: will not tolerate rough handling.

Calibration: requires spectroscope to calibrate.

#### b. Plate Tests Depend on Confusion

(For quick reference see Table 4.2.)

Protanopes confuse certain greens with red and deuteranopes confuse other greens with purple. Pseudo-isochromatic plate tests involve identification of a coloured symbol embedded in a background. The background and symbol are composed of confusion colours that appear clearly different to normals and seem identical (confused) by the truly colour defective. These screening tests identify those individuals with congenital red-green colour defects. They are based either on theoretical properties of a colour vision system or on statistical data about confusion colours from known colour defectives.

Examples: American Optical, AO Hardy-Ryand-Rittler, Ishihara, Dvorine, Tokyo Medical College.

Advantages: provide simple, easy to administer screener for R-G deficits, they are inexpensive, may be used with illiterates and children.

Disadvantages: spectral quality of the light source illuminating the plates is critical, success of the plates depends on the selection of confusion colours which may be difficult to print, and because of eye pigmentation or lens colouration, the selected colours may not be correct for a specific individual.

Validity: the tests generally do well when compared with an anomaloscope; showing agreements of .95 or higher.

Maintenance: plates may be degraded by fingerprints, dust and excessive light exposure. Keep in case and dust free when not in use.

Calibration: no calibration is required by the user. Illuminant C must be used when giving the test.

#### c. Arrangement Tests

(For quick reference see Table 4.3.)

Colour samples are arranged by similarity in a colour series (often a colour circle). Caps are numbered on the back and can be moved freely during testing. Several test strategies are available. They are: colour confusion, hue discrimination and evaluation of neutral zones (colours seen as grey).

Examples:

FM-100	hue discrimination
D-15	colour confusion
Desaturated D-15	colour confusion
Lanthony New	colour confusion and colour test neutral zones

Advantages: tests are easy to administer and can be used with naive subjects.

D-15 discriminates between protan, deutan and tritan defects based on axes of confusion.

FM-100 is based on hue discrimination and is quantitative. It has a long history of use and bases for comparison in hereditary and acquired conditions.

Disadvantages: tests require manual dexterity and may be difficult for some patients. Pigments may be damaged by fingerprints and therefore gloves should be worn. Spectral quality of the light source illuminating the plates is critical.

Validity:

D-15 agreement of .73 - 1.00.

D-15 does not have enough data available for final validation. However, 98% of desaturated dichromats and 70 percent of anomalous trichromats fail the test.

FM-100 may be statistically assessed at  $p < .05$ , or  $p < .01$ . Many validity checks related to age anomaloscope scores, and with the wavelength discrimination function have been carried out.

Lanthony new colour is still under evaluation. Designed for acquired defects and therefore a plethora of test conditions must be considered.

Maintenance: protect from dust and fingertips. Keep in closed box when not in use.

Calibration: caps are made from Munsell colours for which CIE specification is available under illuminant C. No calibration is required by the user.

#### 4.4.2 Lantern Tests

*(For quick reference see Table 4.4.)*

Lantern tests were conceived as occupational tests to evaluate seamen, railway personnel and airline pilots and their ability to discriminate navigational aids and signals. Correct colour recognition is the important variable. Their value lies in their ability to simulate the work place. They do not specifically screen for colour defects. The expectation is that colour defectives will not do as well as normals.

Lantern tests were developed circa 1890 (Cole and Vingrys, 1982) to exclude employees likely to confuse railroad signal colours. It is surprising that even now, the general design of lanterns has not changed very much since the creation of the Eldridge-Green prototype of 1891 (Eldridge-Green, 1920).

The original features remain the same as shown in Table 4.4 for all lanterns.

A single light or pair of lights, usually white, red and green have to be discriminated and named properly. However, other colours including yellow, blue and purple are sometimes used in conjunction with glasses and lenses to simulate various weather conditions.

Even though lantern tests have been used for close to one hundred years, their validation and the availability of information on their reliability is almost non-existent. With the exception of the Farnsworth lantern, for which a number of operational trials have been reported, the evaluation of most lantern tests and the failure rates associated with normals and colour vision defectives are either conflicting or simply insufficient (Cole & Vingrys, 1982).

Disparities between lantern tests are obvious in their of difficulty. The Board of Trade (BOT), the Martin and the Giles-Archer lanterns have been reported to fail six to eight percent of people with normal colour vision (Cole and Vingrys, 1982). The passing rates for colour defective observers vary widely. Passing rates for the BOT and the Martin lanterns and the Giles-Archer are respectively: one out of ten and three out of thirty-six colour defectives tested (Forsey and Lane, 1956). Other lanterns, considered to be more permissive, include the Colour Threshold Tester (CTT), or the Farnsworth, have passing rates as high as one out of three for colour defectives (Lane, 1977).

Over time, new lantern designs have taken advantage of better technology with better and brighter lamps and more precise filters, but without clear reasons being given for such variables as colour selection. The notable exception is the Farnsworth lantern (Farnsworth and Foreman, 1946). In the case of others, there is no real evidence that colours were chosen based on red-green confusion loci for colour defectives nor has the colour separation been well specified (Cole and Vingrys, 1982). These two parameters determine the effectiveness of lantern tests. Since lantern tests have always been perceived to be occupational tests, the colour of the lights have been chosen to represent those found in the transport environment. If the colours do not lie on the confusion loci for inherited red-green defects, the ability to properly assess the deficit is lost. The only device that does not rely on signal lights, but does consider the confusion loci for protans and deutans is the Farnsworth lantern (Farnsworth and Foreman, 1946b).

Test validation for this class of tests is both complicated and perhaps confusing. Cross validation of one lantern against another is confounded because of the differences in intensity, wavelength, target size and test distances. Validation of lantern tests by use of an anomaloscope has never been attempted and cross correlation with plate tests has produced ambiguous results. In most cases, therefore, plate tests precede lantern tests with the notable exception of the US Navy where the Farnsworth lantern is used exclusively.



## 4.5 TEST ADMINISTRATION

Test validity depends on correct administration of the instrument and consistent testing conditions. The section that follows is, perhaps, the most important of this document.

### 4.5.1 Plate Tests

These tests all rely on similar strategies that involve calibrated pigments and must be administered under the same illuminant.

The appropriate lamps are the MacBeth easel with a clear 100-watt incandescent lamp as the source with the blue filter provided by the manufacturer in place or the Verilux fluorescent source provided by Richardson Optical<sup>1</sup>. Illumination of at least 100 lux is mandatory. No other sources are acceptable. Fluorescent lamps, incandescent lamps, or daylight are unacceptable and render the results useless. Studies have shown that under non-standard lighting conditions, some normal observers will fail the test and some dichromats will pass.

The only illuminant present during testing should be illuminant C. Other lights should be extinguished.

Testing is done monocularly at a distance of 75 cm.

Randomisation of test plates is desirable, since some individuals have been found to have memorised the correct answers.

Individuals with 20/200 acuity or better should be able to read the numerals or other figures in the test. Most tests have a "learning" plate or the "malingerer's plate" that should be readable by all, including those with colour deficits.

Scoring procedures vary somewhat from test to test.

American Optical - incorrect responses to five or more plates indicates defective colour vision.

Dvorine - for aviation, five or more errors is a test failure.

<sup>1</sup> The True Daylight Illuminator (Catalog No. 1388R) from Richmond Products, 1021 Rogers Circle, Suite 6, Boca Raton FL, 33487-2894. Phones: 1-800-448-4538 and 407-994-2112. Approximate cost \$170.00.

Farnsworth F2 Tritan Plate - if the blue square is the only one seen or if it is seen more clearly than the green square, a tritan error has been made. If the green square is the only one seen, the subject is making a red-green error associated with an hereditary defect.

Ishihara (16-plate test) - 4 or more errors is deficient. For plates with two digit numbers two errors on one plate are scored as a single error.

### 4.5.2 Arrangement Tests

The observer is asked to arrange colour samples (often bottle caps) in a particular order.

On the back of the caps are numbers used in scoring.

These tests all involve calibrated pigments and must be administered under the same illuminant.

The appropriate lamps are the MacBeth easel with a clear 100-watt incandescent lamp as the source with the blue filter provided by the manufacturer in place or the Verilux fluorescent source provided by Richardson Optical. Illumination of at least 100 lux is mandatory. No other sources are acceptable. Fluorescent lamps, incandescent lamps, or daylight are unacceptable and render the results useless.

Scoring is different for each of the tests. In some cases (FM-100) there are personal computer programs available that make scoring less difficult and reduce errors. In addition, they provide expanded information about the test results.

### 4.5.3 Lantern Tests

These sorts of tests have the advantage of being self-luminant and therefore concerns about the nature and quality of the light source are not present.

This discussion will be confined to the Farnsworth Lantern, since it is the lantern device most commonly in use.

The test is given in a normally lighted room at a test distance of eight feet. The lights are presented randomly. There are nine pairs of lights to be presented. The instructions to the subject are printed on the base of the lamp. Briefly, they are told that they will see an upper and a lower test

light. They are to name the upper light first and then the lower one and that they may only use the colour names “red”, “green” and “white”.

Test stimuli are presented for three to five seconds.

Scoring is relatively simple. If the first presentation of nine pairs of lights is error free, the observer passes. If there are errors, two more consecutive tests are performed immediately without any discussion and with random order of presentation.

The errors are averaged. If there is an average of 1, it is considered a pass. If the average is more than one, it is a failure. If there are no errors on the first run, the second run must still be executed.

## 4.6 SPECIFIC TESTS

### 4.6.1 Anomaloscopes (Other than Nagel):

**Pickford-Nicolson** - is a filter-based system that evaluates the Rayleigh equation and assorted modifications of it. Uses CIE space to plot results. K values are difficult to obtain. Is principally a research tool. Is available from Rayner and Keiller Ltd., London, England.

**Neitz** - mimics the Nagel II and therefore has validity estimates of  $K=.96$ . No longer available commercially.

**Kampeter** - mimics the Nagel, but uses light emitting diodes to generate in free view two fields for making a Rayleigh (red-green) match. Limited data are available, but it seems to do an admirable job. It has the advantage of being portable and more rugged than mechanical devices such as the Nagel.

**Spectrum Colour Vision Meter 172** is a computer-operated system that allows both Rayleigh (red-green) and Moreland (blue-green) colour equations to be evaluated. The system is free view and allows some flexibility, since it uses interference filters that may be replaced to generate non-standard test fields. Limited reliability testing indicates an excellent correlation with the Nagel anomaloscope. The device is expensive and most appropriate for a large test facility and/or research laboratory.

### 4.6.2 Pseudo-isochromatic Plate Tests

Four types of testing strategies have been employed:

1. **Vanishing figure** - figure is easily read by colour normal but may not be read by colour defective.
2. **Qualitatively diagnostic** - vanishing plate that also permits protan-deutan differentiation.
3. **Transformation plate** - 2 figures are present; one, only readable by normals and the other only readable by colour defectives.
4. **Hidden digit** - is a vanishing plate for normals and is seen by colour defectives.

#### AO Pseudo-isochromatic Plate Test

Consists of 15 plates; 14 are test plates and 1 is a demonstration plate that should always be used first - vanishing figures.

Ten or more correct responses indicate normal colour vision.

The test is “...neither qualitative nor quantitative -- that is, it does not classify type of red-green defect or amount of defect.” (From the administration section of the test book)

Validity estimates:

Classification  $K=.90$  have been obtained with some normals remaining unclassified.

#### AO Hardy-Rand-Rittler

Consists of 24 plates including 4 demonstration plates.

Six screening plates - 2 blue-yellow vanishing - 4 red-green vanishing.

Fourteen hidden figure plates - 10 protan or deutan qualitatively diagnostic; 4 tritan qualitatively diagnostic.

Administration:

The six screening plates are given (standard instructions) and the test is halted if all are correctly identified.

If there is an error on the blue-yellow plates, then the 4 blue-yellow hidden figure plates are shown.

If there is an error on the red-green plates, then the 10 red-green hidden figure plates are shown.

#### Scoring:

If the qualitatively diagnostic plates show a majority of protan errors, then the result is "protan".

If the qualitatively diagnostic plates show a majority of deutan errors, the result is "deutan".

If there is no clear pattern on the qual. diag. plates, then the result is "unclassified".

#### R-G severity:

- errors on plates 7-11 = mild deficit
- errors on plates 12-14 = moderate deficit
- errors on plates 15-16 = severe deficit

#### B-Y severity:

- errors on plates 1-2 = unclassified
- errors on plates 17-18 = moderate deficit
- errors on plates 19-20 = severe deficit

Validity estimates (usually classifies correctly, but unclassified category is large):

- Screening K=.88-.96
- Diagnosis K= .22-.91
- Quantitation K= .22-.45

### **Dvorine Pseudo-isochromatic Plates**

Consists of 15 plates, one of which is a demonstration plate.

Administration and scoring are handled in the usual fashion.

Three or more errors indicate a colour deficit.

In aviation, 5 or more errors constitute a failure of the aviation colour vision exam.

#### Validity estimates:

- Screening K=.95

Three levels of colour vision severity have been described:

- 0-2 errors = normal
- 3-4 errors = mild deficit
- 5-11 errors = moderate deficit
- 12-14 errors = severe deficit

### **Farnsworth F2 Plate**

One plate that screens for tritan deficit.

No longer available.

Patient sees as many as two squares that are blue or green on a purple background (circles).

Administration is as for any other plate test.

#### Scoring:

If the individual sees only the blue square or the blue square is clearer than the green square, there is a tritan defect.

If the individual only sees the green square, a red-green deficit is present and should have been detected by prior testing with a red-green screener (see above).

#### Validity:

K estimates are not available.

### **Ishihara's Tests for Colour Blindness**

Tests for red-green deficit and protan-deutan discrimination.

Consists of single or double-digit numbers and trials that are to be traced with a camel hairbrush.

#### 38-Plate test:

- plates 1-21 screen for red-green deficiencies
- plates 22-25 test for protan vs. deutan conditions
- plates 26-38 are trails for testing illiterates

#### 24-Plate test:

- plate 1 is demonstration
- plates 2-15 are screening plates
- plates 16-17 are protan vs. deutan discriminators
- plates 18-24 are trails for testing illiterates

#### 16-Plate test:

- plates 2-9 screen for red green deficiencies
- plate 10 is used to diagnose protan vs deutan conditions
- plates 11-16 are trails for testing illiterates

#### Scoring:

##### 38-Plate test:

- 4 or less incorrect indicates normal colour vision
- 8 or more incorrect indicates a colour deficiency

**24-Plate test:**

- 2 or less incorrect indicates normal colour vision
- 6 or more incorrect indicates a colour deficiency

**16-Plate test:**

- 2 or less incorrect indicates normal colour vision
- 4 or more incorrect indicates a colour deficiency

**Validity estimates:**

Screening:  $K=.95-1.00$

Qualitative Classification:  $K=.10-.70$

There is some problem of legibility confusion with the tests, since the numerals are in script.

**New Standard Pseudo-isochromatic Plates (SPP) - I**

The test is composed of 19 plates that serve as a red-green screening device and differentiates protan from deutan conditions.

Plates 1-4 are demonstration plates showing vanishing figures.

Plates 5-14 serves as a red-green screening device.

Plates 15-19 classify protan vs. deutan defects.

In the screening segment of the test, the figures are composed of two digits. Normals read one or both of the figures; abnormals read only one figure.

In the classification test, protans read one number, deutans read the other number. A keyed scoring sheet makes it easy to keep track of protan vs. deutan responses.

**Scoring:**

If an individual fails the screening test, but reads all of the classification series, the defect is described as "slight red-green".

Other deficits are described on the basis of the number of protan or deutan errors detected during the classification sequence.

If the individual fails both protan and deutan classification figures from the classification plates, the deficit is severe.

**Validity:**

This is a new test with a single estimate of  $K=.91$  for classification =1.00 for screening.

Obviously, more test-retest validation is necessary.

**New Standard Pseudo-isochromatic Plates (SPP) - II**

The test is composed of twelve plates designed to evaluate acquired colour vision deficits, so confusion colours are not involved. The test materials are based on known hue discrimination and saturation discrimination abilities of those with acquired colour vision deficits. In particular, blue-yellow deficits are emphasised since they are characteristic of many acquired defects.

Plates 1 and 2 are demonstration plates.

Plates 3 through 12 are diagnostic plates.

Plates 3 through 11 contain either 1 or 2 numerals that are difficult to detect for blue-yellow defective observers.

Plates 8 through 12 also contain a numeral for detecting red green deficits.

Plates 7 and 12 contain a numeral designed to identify scotopisation.

**Scoring:**

Plate number three is difficult for normals and so a single missed plate is normal. Two misses indicate a suspect and more than two indicates a true blue-yellow deficit. The presence of a red-green deficit is also indicated. Both sorts of deficit may be called out as mild moderate or severe. If only red-green deficits are present, then the patient is most likely has a congenital error and was missed by more appropriate red-green screening procedures.

**Validity:**

This is a new test and has not had extensive validation. When compared to the AO HRR plates and the panel D-15, the test revealed higher percentages of blue-yellow deficits for a variety of diseases known to produce acquired blue-yellow errors. (Tanabe, et al., 1984)

### **New Standard Pseudo-isochromatic Plates (SPP) - III**

The test is a mixture of New Standard Pseudo-isochromatic Plates - I and II.

Plates 1 and 5 through 9 are designed to identify blue-yellow deficits and contain one or two numerals.

Plates 2 through 4 and 6 through 10 are for detection of red-green defectives.

Plate 10 also contains a number designed to identify scotopisation.

#### **Scoring:**

The test is designed to detect "colour vision disturbance" and not to determine the severity of the defect.

If red-green test plates are not correctly read, other tests of red-green vision are recommended.

If both red-green and blue-yellow deficits are found, ophthalmological disorders are to be suspected.

If only blue-yellow numerals are misread (three or more out of seven) and all others are correctly identified then a congenital tritan defect is suspected (extremely rare).

Congenital and acquired defects are possible in the same individual and may produce mixed test results.

#### **Validity:**

No validation tests are in existence at this time. However, since the test is derived from two other tests (see above) some speculation about validity is possible. Both the red-green and blue-yellow parent tests are promising and this test is a good candidate screening tool for congenital and acquired problems.

### **Tokyo Medical College Colour Vision Test**

The test consists of five red-green plates and two blue-yellow plates for screening.

There are three protan-deutan plates for differentiation and three more for severity testing.

Twenty to fifty percent of colour defectives remain unclassified.

**NOT RECOMMENDED.**

### **Stilling-Velhagen Plates**

The tests exist in several forms due to modification over its one hundred-year history. It is important to indicate which version was used. The current version is the twenty-sixth. That edition contains thirty plates. Two introductory plates are included as well as plates for protan/deutan screening and to a lesser extent tritan screening. The test is both a screening instrument and a diagnostic device. Diagnostic plates are scattered throughout the test and that fact makes scoring somewhat difficult for the untrained examiner. The protan plates depend on the impoverished luminosity function of protan observers. No scoring sheet is provided and the instructions are in German.

#### **4.6.3 Arrangement Tests**

##### **The Farnsworth Dichotomous Test (Panel D-15)**

The test consists of fifteen coloured caps that are in equal hue steps on a colour circle and all are of the same brightness.

The test is based on colour confusion. Protans confuse certain reds and greens. Deutans confuse other reds and greens.

Caps which are placed on the wrong side of the circle are considered a major error.

Caps placed in an adjacent position on the same side of the circle indicate a minor error or normal confusion.

Two minor errors are considered to be within normal limits.

Dichromats and extreme anomalous trichromats will produce six to twelve major errors.

Axes on the scoring sheet parallel the protan, deutan and tritan axes and indicate the sort of deficit involved.

The test is failed if there are two or more major errors.

Validity for qualitative classification K=.73-.94.

Quantitative classification is not good.

## **Farnsworth H-16 - NOT AVAILABLE**

### **Desaturated Panel Test 15**

The test is composed of fifteen caps in equal hue steps and of the same brightness arranged around a colour circle.

It was designed for acquired losses and detects mild chromatic discrimination losses when used in concert with the traditional D-15 test.

It is a new test with good prospects. It may be used to classify the severity of red-green congenital problems. It can track the progression of red-green acquired colour vision problems.

Validity has been assessed as:  $K=.98$  for dichromats and  $.70$  for anomalous trichromats.

It is not a screening test and should always be used with the standard D-15.

### **Lanthony New Colour Test**

This test was designed to detect and specify acquired colour defects. It relies on the fact that different acquired conditions produce colour vision wherein certain colours are confused with grey (the neutral zones) and that those colours are different for different disease entities.

The test evaluates chromatic discriminative ability at four saturation levels.

There are four boxes of 15 caps. All are of the same Munsell chroma and lightness and each box is of a different saturation. In addition there are ten grey caps of varying shades of grey.

The test is carried out in two phases; a separation phase and a classification phase.

Separation:

The highest saturation caps are mixed randomly with the grey caps and the patient separates the caps into grey and coloured groups.

Classification:

First the grey caps are arranged from dark to light and then the chromatic caps are arranged exactly as in the D-15 procedure.

The procedure is repeated for all four boxes.

A special chart is used to plot (illustrate) the greys that were included with the colours on a colour circle for the separation results. Then each of the four results from the desaturated colour tests is plotted exactly as the D-15.

Validity is under evaluation. This test is not for inherited defects !!

### **Farnsworth-Munsell 100 Hue Test (FM-100)**

In its present form, the test consists of eighty-five caps in four boxes, used one box at a time. There are no confusion colours in a box and therefore the test is a hue discrimination metric.

The caps are in equal steps of hue around a hue circle.

The results are quantitative, can be subjected to age correction, and are amenable to statistical evaluation.

Validity - since this is the only test of its sort (hue discrimination) cross validation with other metrics is not possible. The test has become the second gold standard for assessing a wide variety of hereditary and acquired conditions.

## **4.6.4 Lantern Tests**

*(For quick reference see Table 4.4)*

### **Eldridge-Green Lantern (1891)**

This test device consists of seven coloured glass filters, seven modifying glass filters and seven apertures. The colour filters simulate signal lights. The modifying filters simulate foggy, rainy, smoky and other meteorological conditions. The apertures simulate changes in distance. Larger aperture sizes may be used in ambient illumination while small apertures require dark adaptation.

The test is complicated by the hundreds of possible combinations of filters and apertures. The test's reliability and variability have never been studied. This lantern was used by the US Navy in 1953 along with the Farnsworth Lantern.

### **Williams Lantern (1892, 1903)**

The 1903 version was intended for use in the railway industry. It is composed of eighteen coloured filters mounted on a rotating disc. It has

three apertures designed to simulate train signal lights at distances from 1600 to 160 feet. A subsequent version of the device used for US Navy evaluation (Farnsworth and Reed, 1943) had a seven-step rheostat and brown filters used to vary intensity. Due to the large number of possible test conditions, this lantern has never been properly validated. Farnsworth and Reed (1943) found that normals and moderately impaired observers made similar errors on the test. No correlation with any other colour vision test has been found.

#### **British Board of Trade Lantern (BOT, 1895)**

There are two models of the BOT; one from 1938 and another from 1943. In the latter, a yellow light was added to the white, green and two sorts of red lights originally used. There are two apertures of 2.9 arc secs for a single light and 17 secs for the pair of lights which when viewed from 20 feet represent a ship's lights separated by 25 feet at 200 and 2000 yards. The test is performed in a dark room after a 15-minute period of dark adaptation with pairs of lights presented in random order four times. Colours are named in pairs by the observer.

The test is quite conservative, with failure rates reported between 4.4 and 9.1% (Topley, 1959).

#### **KBB - Martin Colour Vision Testing Lamp (1939, 1943)**

This lantern is a new design based on the BOT lantern (Martin, 1939). It uses a reduced number of filters (4 instead of 12) a dimming filter was introduced to mislead observers who judge colour based on brightness. The green filter and one of the red filters was chosen to be at the saturation threshold for protan observers so that white and deep red would be confused. The 1943 version introduced an orange filter to make the lantern acceptable by railway authorities.

In the administration of the test, nine pairs of colours are chosen from two sets of combinations. Failure occurs when red is called green or green is called red. When the low-level intensity series is used, white confusion with green or red is permitted, but the test is extended to include dimming filters. As is the case with some other lanterns, there is no standard set of instructions nor is there a simple unambiguous scoring method.

In addition there is no systematic validation data set and the test may fail normal observers due to its difficulty.

#### **Giles-Archer Colour Perception Unit (1940)**

Two models of this lantern have been described. An aviation model with three apertures and eight colours has been used. A second general model with two apertures and six colours is the other form. Interpretation of results is different for each form of the test. The general lantern is failed when green is called red or vice versa. For the aviation model, the process is more complex since yellows may be called orange, some greens may be called yellow and so forth. Forsey and Lane (1967) criticised the ambiguity of the testing and the scoring procedures, even though the test administration procedures are simple.

#### **School of Aviation Medicine Colour Threshold Tester (SAM-CTT, 1943)**

Colour defectives are likely to discriminate between white, green and red at high levels of saturation, but will fail to make the discriminations when light levels are at or near the colour's threshold. This same principle is used in arrangement tests like the desaturated D-15. The intention was to make a lantern that would assess colour recognition at various saturation levels to be used with US Air Force personnel (Rowlan, 1942; Sloan, 1946 and 1948).

Eight lights are involved (2 red, 2 yellow, 2 green and blue and white) at eight luminances. Eight colours were presented in order while alternating the high and low intensities. The order of the colours was reversed for higher versus lower light levels. A complete test involved eight colours at eight intensity levels. The subject named colours for each presentation. Due to the intensity range involved, some latitude in colour naming was necessary. Thus yellow, amber and orange were acceptable names for the same dark yellow filter as light intensity changed. The order of colour presentation has been shown to influence colour perception (Working Group 41, 1981) and the test may be criticised on those grounds. In addition the lack of randomisation could permit some incisive observers to discover the colour sequence and pass the test for the wrong reasons.

There have been attempts to validate the test (Rowlan, 1942; Sloan, 1946; Sloan; and Wollach, 1948; Schmidt, 1951). Test-retest correlations for immediate retesting and retesting after one week to six months were 0.942 and 0.876 (Sloan and Wollach, 1948).

Although a score of 60 out of 64 is required to demonstrate good colour vision, a score of 50 has been thought to be sufficient to identify aviation signals without difficulty (Sloan, 1946). It has been reported that 12% of colour defectives may pass the SAM CTT tests as well as 11% of those who are moderately deuteranomalous (Paulson, 1971). In addition, when 224 colour defectives were evaluated, 18.5% of the protanomalous subjects were able to pass the test. This high level of undetected protanomaly has been thought to be unsuitable and the test has been discontinued by many organisations (Cowan, 1987). Additionally, the filter material used deteriorates over time and renders the test unusable. It has been withdrawn from use by the US Air Force.

#### **Holmes-Wright Lantern (1974)**

This device was developed in response to a request from the British Parliament for a review of vision test standards for those serving or wishing to serve in the Merchant Navy, or in the fishing fleet.

#### **Farnsworth Lantern (1946)**

The most representative device and the only one readily available is the Farnsworth Lantern (Falant). The test uses red, green, and white lights that are confused by people with more severe colour deficits and does not attempt to mimic navigational aids. The assumption is that, if an observer can see the lights that colour defectives can't see, then they should certainly see those colours that colour defectives don't fail. The test passes thirty percent of colour defectives.

Nine vertical pairs of lights are presented to the observer. One of the two stimuli is twice as bright as the other. The device is self-luminous and may be used in normal room light. The bulb is rated for 1000 hours and a replacement bulb is in the base. Random presentation is easy to accomplish and administration and scoring do not require highly trained personnel.

Availability of the device has been an "off and on" problem and only limited information is available

about validity. No maintenance or calibration is required. CIE chromaticity specifications are available.

#### **Beynes Lantern (1925)**

It is the lantern used by French Air Force. Beynes Lantern uses red, green, blue, white and yellow. The device is self-luminous and may be used in dim room light. Size and exposure time of one colour can be adjusted. The subject sits five meters from the device and has to name colour for each presentation.

No error is acceptable.

### **4.6.5 Other Tests**

#### **Holmgreen Wool Test - Skein Test**

No scoring instructions are available for the test.

The yarns from which test samples are made fade with time.

No validity data exist.

NOT RECOMMENDED.

### **4.6.6 Emerging Technologies**

Colour vision test development is slow and an unusual event. In the recent past, a self-contained device for "plotting" colour vision defects has been described (Gunkel, et al., 1986). It is posited that traditional colour vision testing metrics are not very effective at identifying specific wavelengths for which colour vision is defective, nor is the severity well specified. This is especially true for acquired deficits. A device is described which plots, on a colour circle, the ability to see mixtures of three primary colours similar to Wright's primaries (Wright, 1946). The apparatus is constructed so that a mixture of the three primaries (suitably adjusted for equal luminance) will produce "white" and will be located at the centre of the circle. Radii, emerging from the white point are each of a wide range of hues including red, magenta, blue, turquoise, green and yellow. As one proceeds along any of the radii, the hue changes from white to a desaturated colour that becomes more and more saturated and thus more visible. The examination, then, is one of plotting (much like a tangent screen visual field), the extent of the neutral region for the disease state



under investigation. The neutral region is an area in colour space that appears white or grey to the observer. Normal colour vision in this test then would show only a small area at the centre of the circle that is neutral, the rest is chromatic. The test consists of moving slowly out any of the axes and marking the point where the correct name for that radius's colour occurs. When mapping the neutral region for various diseases, a sector is outlined. The severity of the disease is indicated by the length of the sector and its width. The precise colours involved are indicated by the radii involved. This appealing test, has to our knowledge, not come into common use.

Three sorts of new PC-based testing modalities are emerging as promising. The advent of the personal computer (PC) opens up the possibility of universal colour vision testing. The notion of a health-care provider having a battery of colour vision tests literally on the desktop is, at face value, quite attractive. The system would be inexpensive, versatile, and would offer ease of test administration and scoring with the possibility of suggested diagnoses provided by the machine.

First, there is a system that mimics existing tests and devices.

**Two Docs** is a PC-based battery of tests from Two Docs Inc. of New Orleans, Louisiana. The included metrics are:

1. Plates - a test of colour confusion intended as a screening device.
2. Hue 16 - is "...a colour arrangement test designed to detect chromatic discrimination loss in both congenital and acquired colour variations."
3. Ninety Hue Test - is a more sophisticated test involving hue discrimination and its loss across the visible spectrum that may also be used to follow disease processes.
4. Rayleigh anomaloscope - is a PC implementation of an anomaloscope for evaluation of red-green anomalies.
5. Moreland anomaloscope - is a PC implementation of a blue-yellow anomaloscope useful in "tritan" deficits.
6. Whittenburg anomaloscope - is a PC implementation of "...a colour matching test similar to the Rayleigh anomaloscope which explores the red-blue spectrum."

7. New Colour Test - is a test designed to evaluate saturation and lightness sensitivity losses over the visible spectrum.
8. Sinusoidal Gratings Contrast Sensitivity Test - is a testing module that evaluates both black and white spatial visual resolution and blue-yellow resolution as well.
9. Contrast Sensitivity and Colour Contrast Sensitivity Tests - is designed to do luminance contrast testing as well as chromatic contrast testing.
10. Calibration - is intended to allow standardisation of monitor attributes.

All of these resemble (mimic) existing colour tests, except the Whittenburg anomaloscope and have a familiar "feel". However, there are some well-known problems with colour display systems that should be pointed out. Displays age over time, are sensitive to line voltage fluctuations, may have sensitivity to magnetic fields, may require alignment of the three electron guns responsible for colour generation to assure purity and registration, and are sensitive to DC - offset and gain. The simple version of the system uses a screen calibration process that involves adjustment of the appearance of grey circles by the user. The plethora of monitors makes it highly unlikely that each user will achieve the same end result. It should be noted that two specific brands of monitor are recommended as well as two sizes. It is suspected that an individual user with the "wrong" monitor is unlikely to purchase one of the recommended brands. A research grade device is sold with an optical colourimeter. That combination would improve the likelihood of success with this approach.

Although the Two Docs software includes scoring and indicates a diagnosis, they state: "The results provided by the SOFTWARE are not a medical opinion or diagnosis."

This sort of compelling approach to the problem of inexpensive testing of acquired and congenital colour vision defects will some day be possible when the technology is indeed fool-proof and calibration is no longer a pitfall.

Second, there are those who have successfully attempted to deal with the thorny problem of eliminating the influence of luminance and spatial contours when attempting to extract responses

based on chromatic signals. Several authors have attempted to develop tests wherein the subject detects the presence of a coloured spot or grating on an equiluminant field on a raster display. (King-Smith, Chioran, Sellers and Alvarez, 1983; Fallowfield and Krauskopf, 1984; Hart, Hartz, Hagen and Clark, 1984; Sellers, Chioran, Dain, Benes, Lubow, Rammohan and King-Smith, 1986; King-Smith, Vingrys and Benes, 1987; Heard, Stone, Gregory and Marmion, 1987; Arden, Gündüz and Perry, 1988; Cuvinot, 1992). Equiluminance is necessary, of course, in order to control (null out) the influence of the luminance signal and leave only chromatic variables. Unfortunately, each individual has his or her own equiluminance value and the problem is even more difficult among colour defectives. The necessary process of finding that value before colour testing may begin is time consuming and negates the value of a *quick* and simple test that is display based. Additionally, slight misalignment of colour generating guns in display equipment may produce edge artefacts that reveal a chromatic boundary. Mollon (1994) and his group have adopted strategies to cope with these problems with seeming success. They point out that in 1877, Stilling discovered that to eliminate edge artefacts involved with printing solid objects on a uniform background, it was necessary to break the target and background into many small patches each with its own contour. In addition, the problem of equiluminance for different observers was handled by a special technique. Instead of equating the lightness of target and field, which won't work, the varied the lightness of the individual patches (Stilling, 1877). "The test avoids the need, common to most computer-controlled tests, to define equiluminance for the individual subject before the colour test itself can be administered." Luminance noise and masking contours are used to insure that the subject's responses are based solely on chromatic signals. The stimuli are easily presented by computer and these new generation pseudo-isochromatic stimuli were able to separate protans from deutans and to demonstrate the large range of "...chromatic sensibilities among anomalous trichromats". It would seem, that a proper sense of history has provided a technique of great contemporary use.

Third, is a completely different approach that reasons from an ergonomic point of view. It has been pointed out that there are several levels of dysfunction as defined internationally (Wood, 1980).

#### Illness----Deficiency----Disability----Handicap

The above "spectrum" has produced different sorts of testing strategies for each category with respect to colour vision. Illness, best described by the acquired deficits may be approached by such tests as the Lanthony New Colour test, the New Pseudo-isochromatic Plate Test II or the Moreland anomaloscope. Deficiency is usually hereditary and may be evaluated by standard pseudo-isochromatic plate tests such as the Ishihara or by Nagel anomaloscope or the Farnsworth-Munsell 100 Hue test. Disability is usually of vocational concern and the lantern tests that were designed for vocational testing are the appropriate tools. The Farnsworth Lantern is one such device that was designed for the military or transportation industry to discover those observers that were able or not able to correctly identify signal lights. Handicap has been largely ignored and requires a special approach. A PC-based system has been designed and is designated PROCOPAT by its creator Jean-Pierre Menu. The tests are not designed to be screening devices, but rather are intended to evaluate the occupational "readiness" of an individual.

The battery is in two major parts. First there is a colour-naming phase. Two sizes of squares are presented separately, one degree and four degrees. Presentation time is either two hundred or four hundred milliseconds. This phase is a colour-naming task intended to factor out those colours that are somewhat difficult to see and constitute a handicap. After practice, the test begins with presentation of individual colours from the sample set used during the practice trials. The subject signals the name of the colour presented in the centre of the screen. Phase two consists of two sub-phases, one a labyrinth and the other a wire grid. Colours for the labyrinth are assigned based on errors made during the colour-naming test. For example, someone with a red-green handicap might have a labyrinth whose walls are red with a green trail. The mouse is used to follow the green trail from a point labelled "start" to the "stop" point. Practice is given and then a timed trial follows.

Successful completion depends on going from "start" to 'stop' leaving the trail the fewest times. Time to complete the task is determined. The test which follows is a "wire frame" composed of line segments of two different hues. The subject must follow with the mouse the lines of one of the

colours and click on intersections with other lines of that same colour, but not the intersection with a second colour. The time to complete the task is determined. These two tasks are examples of what may be done with a program of this sort. Other tasks may be developed to test the skills necessary for a particular profession such as aviation, electronics or even fabric dyeing. It should be emphasised that this is, for many, a different way of looking at proficiency with colour vision and may provide a long needed new way to link colour vision testing and performance. As was the case with Two Docs, calibration procedures and display stability are also of concern.

PC-based test systems will no doubt play a role in colour vision analysis from a variety of perspectives, especially as display technology proceeds.

### Enhanced Colour Screening - Diagnosis of Red-Green Defectives

The anomaloscope is the only device that may be used to classify genetic colour vision problems; but, it is expensive, time-consuming and requires a trained examiner.

Plate and arrangement tests used for screening are designed to identify individuals who may need more extensive colour testing; they do not diagnose a colour defect. Individual laboratories may need to establish a battery of tests to satisfy their needs. For Example: USNMRL developed a test battery for determining the degree of a colour vision defect (Table 4.1).

**Table 4.1: USNMRL Test battery for determining degree of colour vision defect**

Class	Type	Test			
		Plates	Falant	Farnsworth Panel D-15	Farnsworth Panel H-16
I.	Normal Trichromat	Pass	Pass	Pass	Pass
II.	Anomalous Trichromat (mild defect)	Fail	Pass	Pass	Pass
III.	Anomalous Trichromat (moderate defect)	Fail	Fail	Pass	Pass
IV.	Anomalous Trichromat (severe defect)	Fail	Fail	Fail	Pass
V.	Dichromat	Fail	Fail	Fail	Fail

## Colour Vision Regulations

In today's complex colour environment, there are a variety of standards for colour vision that are due to the requirements of occupations and job demands. Consequently, the flight surgeon and other eye-care professionals will be called upon to evaluate the quality of colour vision of prospective fliers, trainees, rated flying personnel, control tower operators and electronics specialists.

## 4.7 REFERENCES

1. Arden, G., Gündüz, K. and Perry, S., Color vision testing with a computer graphics system: Preliminary results, *Documenta Ophthalmologica*, 1988, 69, pp 167-174.
2. Asenjo, A.B., Rim, J. and Oprian, D.D., Molecular determinants of human red/green colour discrimination, *Neuron*, 1994, 12, pp 1131-1138.
3. Bishop, Y.M., Fienberg, S.E. and Holland, P.W., Discrete multivariate analysis: Theory and practice. Cambridge Mass.: MIT Press, 1975.
4. Boynton, R.M., "Human Color Vision", Holt, Rinehart and Winston, New York, 1979.
5. Cohn, S.A., Emmerich, D.S. and Carlson, E.A., Differences in the responses of heterozygous carriers of colour-blindness and normal controls to briefly presented stimuli, *Vision Research*, 29, 1989, pp 255-262.
6. Cuvinot, P., Mesures et développement de tests ophtalmologiques sur le GEPCO, Mémoire d'ingénieur, Conservatoire National des Arts et Métiers, Paris, 1992.
7. Fallowfield, L. and Krauskopf, J., Selective loss of chromatic sensitivity in demyelinating disease, *Investigative Ophthalmology and Visual Science*, 1984, 25, pp 771-773.
8. Gunkel, R.D., Roy, M.S., and Roy, A., Measurement of color thresholds, *American Journal of Optometry and Physiological Optics*, 1986, 63, pp 16-21.
9. Hart, W.M., Hartz, R.K., Hagen, R.W. and Clark, K.W., Color contrast perimetry, *Investigative Ophthalmology and Visual Science*, 1984, 25, pp 400-413.
10. Heard, P.F., Stone, C.J., Gregort, R.L. and Marmion, V.J., A new computer graphics test for red/green colour anomaly, In Verriest, G. (Eds), Colour vision deficiencies VIII, 1987, pp 181-194, Dordrecht: Junk.
11. Horner, F., Die Erbllichkeit des Daltonius: Ein Beitrag zum Vererbungsgesetz. Amtl. Ber. Verwaltung d. Medizinalwesens Kanton Zürich, 1876, pp 208-211.
12. King-Smith, P.E., Vingrys, A.J. and Benes, S.C., Visual thresholds measured with color video monitors, *Vision Research*, 12, 1987, pp 73-80.
13. King-Smith, P.E., Chiroan, G.M., Sellers, K.L. and Alvarez, S.L., Normal and deficient colour discrimination analysed by colour television, In Mollon, J.D. and Sharpe, L.T. (Eds) Colour vision: Physiology and Psychophysics, 1983, pp 167-172, London: Academic Press.
14. Merbs, S.L. and Nathans, J., Absorption spectra of human cone pigments, *Nature*, 356, 1992, pp 433-435.
15. Nathans, J. and Hogness, D.S., Isolation, sequence analysis and intron-exon arrangement of the gene encoding bovine rhodopsin, *Cell*, 34, 1983, pp 807-814.
16. Nathans, J., Thomas, D. and Hogness, D.S., Molecular genetics of human colour vision: The genes encoding blue, green and red pigments, *Science*, 232, 1986a, pp 193-202.
17. Nathans, J., Piantanida, T.P., Eddy, R.L., Shows, T.B., and Hogness, D.S., Molecular genetics of inherited variation in human colour vision, *Science*, 232, 1986b, pp 203-210.
18. Neitz, M., Neitz, M. and Jacobs, G.H., Spectral tuning of pigments underlying red-green colour vision, *Science*, 252, 1991, pp 971-974.
19. Pokorny, J., Smith, V.C., Verriest, G. and Pinckers, A.J.L.G., Congenital and Acquired Colour Vision Defects, Grune and Stratton, New York, 1979.

20. Pokorny, J., Collins, B., Howett, G., Lakowski, H., Lewis, M., Moreland, J., Paulson, H. and Smith, V., Procedures for Testing Color Vision: Report of Working Group 41, National Academy Press, Washington D.C., 1981.
21. Sellers, K.L., Chioran, G.M., Dain, S.J., Benes, S.C., Lubow, M., Rammohan, K. and King-Smith, P.E., Red-green mixture thresholds in congenital and acquired color defects, *Vision Research*, 1986, 26, pp 1083-1097.
22. Stilling, J., Die Prüfung des Farbensinnes beim Eisenbahn-und Marine-personal. Cassel: Theodor Fischer.
23. Tanabe, S., Hukami, Kaitiro and Ichikawa, New Pseudo-isochromatic Plates for Acquired Colour Vision Defects, in Verriest, G. (Ed), *Colour Vision Deficiencies VII*, Junk, The Hague, 1984, pp 199-204.
24. Wright, W.D., *Researches on Normal and Defective Colour Vision*, 1946, London: Henry Kimpton.

**Table 4.2: Review of the plate tests available for colour vision clinical assessments**

Test	Availability	Administration		Scoring Method & Interpretation	Intro Plate	Number of Plates	Types of plates				Notes	General Evaluation
		Easy	Hard				Vanishing	Transformation	Hidden	Diagnostic		
ISHIHARA PLATES	Recognised world-wide by civil and military licensing authorities Four different editions with 14, 16, 24 and 38 plates are available	X		Number of errors No scoring sheet available Type of defects assessed by means of errors made	(1)	(24) Standard (12) Illiterate	Yes Number varies with the edition	Yes Number varies with the edition	Yes Protans Deutans Number varies with the edition	People with poor visual acuity or hue discrimination may fail the vanishing and the transformation plates Not possible to distinguish dichromats from anomalous trichromats	Classified as the best in its category with 5th Edition Validity of *K 0.95-1.00 for screening	
DVORINE PSEUDO-ISOCHROMATIC PLATES	Recognised by many civil and military licensing authorities	X		Number of errors Severity of defects can be assessed by means of error made	(1) For illiterate subjects	(14) For literate (7) For illiterate subjects; paths to be traced	None	None	(2)	Score sheet available Good instruction manual Provide a colour naming test in addition to the pseudo-isochromatic designs	Very Good Validity of *K 0.95-1.00 for screening	
AMERICAN OPTICAL COMPANY (HARDY-RAND-RITTLER) AO HRR	Widely used especially in the USA	X		Number of errors No scoring sheet available Severity of defects can be assessed by means of errors made	(4) Which screen for hysteria and malingering	(24)	No	(14)	(4) Protans Deutans Tritans	Diagnose tritan Diagnose and grade protan and deutan (mild, medium, strong) 1954 Edition is out of print but still widely used	Good Validity of *K 0.88-0.97 for screening	
STILLING-VELHAGEN PLATES	Instructions are only in German		X	Number of errors Interpretation of results is difficult because diagnostic plates are scattered throughout the test No scoring sheet are available	(2) in last edition; 26th	(30) in last edition; 26th Varies from one edition to the other	Yes		Yes but no systematic grading is included	There was a 28th edition made Variation in number of plates among editions Variation in the design, dot size, stroke width, symbols Variation in the relative efficiency of the plates	Fair	
OKUMA PLATES	Instructions are only in Japanese		X	Number of errors Hard to administer because the plates are loose cards No scoring sheets are available	(1) and (1) Landolt sample ring card	(7) screening plates	(4)	(1)	(3) Protans (3) Deutans	Colour used similar to Ishihara plates Diagnostic plates are similar to the system of the AO HRR plates but the colour has been changed	Fair	

Table 4.2 continued: Review of the plate tests available for colour vision clinical assessments

Test	Availability	Administration		Scoring Method & Interpretation	Intro Plate	Number of Plates	Types of plates				Notes	General Evaluation	
		Easy	Hard				Vanishing	Transformation	Hidden	Diagnostic			
STANDARD PSEUDO-ISOCHROMATIC PLATES (Ichikawa, Hukami, Tanabe, Kawakami)		X		(See text)	(4)	(10)	(10)			(3)	<p>Numerals are digital-type format such as the one presented by calculators and clock radios</p> <p>In the diagnostic plates two digits are present but one is read by protans and the other by deutans</p>	<p>Promising test especially for qualitative evaluation i.e. discrimination of protans vs deutans with a 'K' of 0.91</p>	
					(2)	(10)	(10)			<p>Designed for acquired defects</p>			<p>A new and promising test under validation</p>
					(0)	(10)	(10)						
AMERICAN OPTICAL COMPANY PLATES (1965) (AO PLATES)		X		<p>Normal people are allowed up to 4 partial errors</p> <p>Scoring sheet is available</p>	(1)	(14) from various tests (6) of them are confusing designs	(7) from Stilling-Velhagen and Folack Tests (7) other			<p>Combined plates from various test</p> <p>Bad colour quality and confusing designs</p>	<p>Worst in its class</p>		
BOSTROM-KUGELBERG PSEUDO-ISOCHROMATIC PLATES (BK)	<p>Instructions are only in Swedish</p>		X	<p>There is an age effect for the red-green plates i.e. older normal subjects can be misclassified as red-green defectives</p>	(3)	(16)				<p>Three plates without digits to detect malingering</p> <p>Two plates for illiterates</p>	Fair		
F2 PLATE (FARNSWORTH)  from Naval Research Submarine Laboratory, Box 900, Groton, CT 06349	<p>Not available commercially</p>		X	<p>Care has to be taken in interpreting patients responses because the examiner cannot rely on the colour naming for the square(s) seen</p>	None	(1)				(1)	<p>Can be used either for congenital or acquired colour defects</p>	<p>Good</p> <p>Validity of 'K' 0.90 for screening</p>	

**Table 4.3: Review of the arrangements tests available for colour vision clinical assessments**

Test	Usage	Content	Scoring Method	Interpretation of results	Reliability	Validity	Notes
FARNSWORTH DICHOTOMOUS TEST FOR COLOUR BLINDNESS (PANEL D-15) from House of Vision, 137 N Wabash, Chicago, IL 60602	Select Dichromats Extreme anomalous trichromats Anomalous trichromats	(14) Movable colour samples with one fixed colour sample	Misplacement of colour caps results in minor errors or major errors if crossover are apparent on scoring sheet	Defective axes are already recorded on scoring sheets Pass-Fail is relevant only when administered as part of a test battery	$\kappa = 0.96$	Quantitative evaluation $\kappa = 0.53-1.00$ Qualitative evaluation $\kappa = 0.73-0.94$	Designed to be used after the Farnsworth Panel D-15 Test appears almost white due to desaturation
LANTHONY DESATURATED PANEL D-15 TEST	Select subjects with mild chromatic discrimination loss	(15) Movable colour caps with one reference fixed cap	Same as Farnsworth D-15 panel	Normal subjects will complete test with only minor errors Simple anomalous trichromats make minor and major errors Dichromats and extreme anomalous trichromats make multiple errors with many cross over lines	Not enough data to calculate a $\kappa$	82% of congenital colour defective will fail the test 98% of dichromats 70% of anomalous trichromats	
FARNSWORTH H-16 TEST not commercially available but the Naval Research Submarine Laboratory, Box 900, Groton, CT 06340 has sometimes granted a few requests	Select Dichromats Anomalous trichromats	(15) Movable colour samples with one fixed colour sample		Parallel crossover discriminates protanotropes from deuteranotropes Anomalous trichromats will make many minor errors in the mid-section of the test	$\kappa > 0.90$	Not enough data to calculate a $\kappa$	Higher chroma than the Panel D-15 Not enough data to calculate a $\kappa$
FARNSWORTH-MUNSELL 100-HUE TEST	Discriminate among people with normal colour-vision Measure areas of colour confusion among colour defective	(85) Movable colour caps in (4) boxes of 21 or 22 colours	Error scores are calculated according to the distance between two caps	A general error score is derived from all the errors made on the (4) boxes Characteristic position of colour poles differentiates between defects The locus of the centre cap is also characteristic of a congenital defects	Improvement may be seen after the first retest Not enough data to calculate a $\kappa$	Normal subjects will commit asymmetric errors Influence by level of illumination Not enough data to calculate a $\kappa$	Not designed for screening Age norms have to be defined Number of errors increase with age
SAHLGRENS SATURATION TEST	Evaluate loss of saturation discrimination in acquired colour defects	(12) Caps; (5) greenish blue, (5) bluish purple both groups of varying saturation plus (2) grey caps	Grey caps have a score of 0, coloured cap scores of 5, 10, 20, 30 and 40 Score is given by summing up the saturation score on the back of the caps that were left as grey	A score of 10 is considered the upper normal limit	Not available	45% of those with congenital colour defects and 90% of those with acquired colour defects have abnormal scores varying from 0 to >50	To be performed under illuminant C Further validation is required
LANTHONY NEW COLOUR TEST (NCT)	Determination of neutral zone for acquired colour vision defects according to colour caps confused with grey at four saturation levels	(4) Boxes of the same hue but with different chroma (Munsell chroma 8.6.4.2) each with 15 caps	Scoring separation phase by the position of the colour caps wrongly placed Scoring classification by the position of the colour caps among grey caps	The separation phase give an indication of the neutral zone by the grouping of colour caps among grey caps which is characteristic of congenital or acquired colour defects The classification phase allows determination of relative luminosity by position of colour caps in the grey scale	Not enough data to calculate a $\kappa$	Validation for acquired colour defects is still on its way	Designed specifically for acquired colour defects



**Table 4.4: Review of lantern tests available for colour vision clinical assessments**

Test	Usage	Content	Scoring Method	Interpretation of results	Reliability	Validity	Notes
BRITISH BOARD OF TRADE LANTERN	Ability to assess light signal recognition in military, aviation and transport world	For the original lantern; 12 filters of various, reds, greens, and clears For the modified lantern of 1938 (4) filters; (1) green, (1) clear and (2) different reds For the modified lantern of 1943 (5) filters (1) green, (1) clear, (1) yellow and (2) different reds Lights are presented either singly or in horizontal pairs. The size of the lights are representative of ship's lights at 200 and 2000 yards have to be named or compared by the subject	No standardised method of scoring has ever been developed	Number of errors in discriminating the colour of the light(s) presented give qualitative evaluation of colour discrimination	No studies are available	No studies are available	Administration is complicated because of the controls for selecting coloured lights, aperture size, single vs paired presentation and placements of the neutral filters for the 1938 and 1943 models
COLOUR THRESHOLD TESTER	Ability to discriminate lights close to those for the standards of aviation signal colours Ability to discriminate lights that would normally be difficult for those who are colour defective	Eight coloured lights at eight levels of luminance in various sequences are presented one at a time and have to be named by the subjects	Number of errors 95% of normal subjects will have a perfect score of 64/64	Interpretation is sometimes ambiguous for low intensities	For colour defective people: 0.94 for the same day and 0.80 for consecutive days	Broad distribution in colour defective people	The method of administration is flawed: No randomisation Contamination of colours induced by filter changes over time Sequence of colour presentation changes with every run
ELDRIDGE-GREEN LANTERN (1891)	Designed to produce a range of colours and tints	(7) Coloured ground glass filters (represent signal colours) (7) Modifying glass filters; ground, ribbed, neutral etc, glass (represent fog, rain, smoke etc) (7) glass apertures size (represent different distances)	Although there are rules for the scoring, usually the test resolves into a subjective contest of colour naming	Ambiguous	No studies are available	No studies are available	Hundred combinations possible Complicated by five rotating discs
FARNSWORTH LANTERN (FALANT)	Developed for the US Navy is designed to pass normal trichromats and some mild dichromats but to fail severe colour defective subjects	(6) red, (6) green, (6) white filters and (9) dimming filters The lights used are specifically those that are confounded by the colour defective people; the colours are not produced by filters	Errors made in the presentation of nine pairs	Once errors are made in the first run two recheck runs are undergone Average $\leq 1$ = pass Average $\geq 1.5$ = fail	*K 0.98		One of the most widely used lantern tests Liberal test known to pass some known colour defectives

**This page has been deliberately left blank**



**Page intentionnellement blanche**

## Chapter 5

### Acquired (Transient and Permanent) Colour Vision Disorders

J. Terry Yates, Ioannis Diamantopoulos and Franz-Josef Daumann

In addition to the congenital disorders of colour vision, *acquired permanent* disorders of this sensory system are known. They result from alterations in the anatomical structure of the eye, the visual pathway and the cortical receiving areas. Such disorders are rarely observed in the flying community. There is another form of colour vision disorder that is of a *temporary* nature, and may arise from many different causes. Table 5.1 delineates the differences between congenital and acquired defects and should serve as a guide for preliminary discrimination between the two conditions.

#### 5.1 COLOUR DEFICITS - ACQUIRED

A variety of retinal diseases, brain injuries and responses to toxic substances will produce colour vision defects including: central serous retinopathy, drug and toxic poisoning from lead, tobacco and alcohol, multiple sclerosis and damage to areas 17 and 18 of Brodmann. These problems may be classified into three broad categories.

##### 5.1.1 Type I Acquired Red-Green Deficits

Red-green chromatic discrimination progressively deteriorates. There is an accompanying loss of visual acuity.

The photopic luminosity function (curve) becomes more and more scotopic.

In advanced stages, there is total colour blindness that resembles congenital achromatopsia.

This condition is associated with retinal diseases, especially those involving photoreceptors of the posterior pole (macular cones are destroyed).

The photopic luminosity function is normal.

##### 5.1.2 Type II Acquired Red-Green Deficits

There is a red-green discrimination loss which is moderate or severe with a concomitant.

Blue-yellow loss that is mild.

Table 5.1: Characteristics of congenital vs. acquired colour vision (CV) defects

CONGENITAL	ACQUIRED
Colour loss in specific spectral region	Often no clear cut area of discrimination loss
Less marked dependence of CV on target	Marked dependence of CV on size and illuminance
Characteristic results obtained on various clinical CV tests	Conflicting or variable results on clinical CV tests
Many object colours are named correctly or predictable errors are made	Some object colours are named incorrectly
Both eyes are equally affected	Eyes are affected asymmetrically
Usually no other visual complaint	May have decreased acuity and field loss
Defect is stable	Defect is labile with progression or regression

The apparent saturation of colours is decreased and in advanced cases, the 500 nm region of the spectrum looks grey to the patient.

In late stages, there is eccentric fixation with nearly complete achromatopsia.

Seen in:

- optic neuritis
- retrobulbar neuritis
- optic atrophies
- O.N. intoxication
- malformed disc
- O.N. or chiasm tumours

### 5.1.3 Type III Acquired Blue-Yellow Deficits

This is the most frequent acquired deficit. There is a mild to moderate blue-yellow sensitivity loss. In the early stages there is a blue deficit. However in the later stages the disease proceeds to dichromacy with a neutral zone (that appears grey) around 500 nm.

Seen in:

- |                             |                                  |
|-----------------------------|----------------------------------|
| nuclear cataract            | chorioretinal inflammation       |
| vascular disorders          | chorioretinal degeneration       |
| papilledema                 | autosomal dominant optic atrophy |
| senile macular degeneration | glaucoma                         |

Caveat: normal ageing of the retinal pigment epithelium and retina may give similar symptoms.

## 5.2 COLOUR VISION DISORDERS CAUSED BY ILLNESS

Acquired colour vision disorders are characterised by unilateral or bilateral alterations in the function of the retina or the conduction pathways leading from the retina to the cerebral cortex. In most cases, acquired colour vision disorders have a concomitant deterioration in visual acuity, exhibit visual field defects and may show other functional disorders of the sensory end organ. Common to all acquired colour vision disorders is retention of the patient's colour perception in visuosensory memory. This phenomenon results in the patient being able to describe the colour of objects as they

are, in fact, seen. Comparisons between normal and abnormal colour percepts are possible and may be verbally described. This is especially true in cases of unilateral affliction. Compared with patients with a congenital condition, patients with an acquired condition are at an advantage, because they are capable of recognising and understanding the effects of their disorder on flight safety.

Acquired disorders often go hand-in-hand with a deterioration in visual acuity. Faulty colour perception can be found, on the one hand, in alterations in the dioptric apparatus (cornea, lens or vitreous body) and, on the other hand, in cases where the retina or choroid are affected; in other words, in cases of such entities as retinitis, choroidoretinitis, central haemorrhaging, myopic choroid atrophy and macular degeneration in old age. Detrimental noxious substances such as alcohol, nicotine, lead and sulphur, as well as hydrocarbons and medication, can all lead not only to transient but also to permanent colour sense disorders.

Rare cases have been recorded of a genetic disposition such as Leber's optic atrophy leading to faulty colour perception at the early age of between twenty and thirty years.

With regard to auto-immune illnesses, the initial symptoms of multiple sclerosis affect the optic pathway, and later the symptoms become more general in nature.

Attention should also be paid to other pathologically based colour sense disorders; for example, trauma which may affect any of the various eye tissues, resulting in visual and colour disorders.

Infections may also lead to disorders of the neural pathways, of the dioptric apparatus, and even of the brain, may produce colour abnormalities along with more general visual disorders.

Histogenesis in the area of the eye, or even of the cerebral pathways and the cerebrum, can cause isolated colour sense disorders. Such isolated disturbances occur in cases of blood supply deficiency caused, for example, by vaso-occlusion, vascular spasms, embolae, thromboses or vaso-constrictions.

Haemorrhages in the vicinity of the eye, the optic nerves and the brain can also lead to visual disorders, and therefore to colour sense disorders.

Isolated cases of vasculitis, such as temporal arteritis, are examples of colour vision disorders found in elderly patients. To complete the picture, glaucoma should be mentioned. Additionally, metabolic illnesses such as diabetes and Parkinson's disease, and all symptoms of deficiency, must be included in this catalogue of causes of colour sense disorders. Finally, colour recognition can be altered or disrupted as a function of age. Known causes include illnesses such as macular degeneration and cataracts, which, may not affect just colour vision. Table 5.2 that follows this chapter, delineates the sorts of colour vision deficits seen with a variety of disease states.

### 5.3 COLOUR VISION DISORDERS CAUSED BY PHYSICAL AND PHYSIOLOGICAL INFLUENCES

In addition to permanent or transient colour vision disorders, and those acquired through illness, disorders may also be caused by the different environmental conditions encountered in flying operations.

Hypoxia comes first to mind in this connection. It is caused by insufficient oxygen saturation of the respired air (*hypoxic hypoxia*). Hypoxia can, however, also be caused by a reduced oxygen supply due to the absence of red blood cells that carry oxygen. For example anaemia, whether caused by haemorrhaging or erythropoietic deficiency, may produce *hypoxemic hypoxia*.

An acquired heart disease or affliction of the circulatory system, as well as physical influences on the circulation such as those caused by vertical G loading of the body (+ Gz), lead to an insufficient blood supply to the brain, resulting in visual and colour perception disorders, due to *stagnant hypoxia*. Cases of *histotoxic hypoxia* due to pharmacologically toxic influences are also known to exist.

Pilots, and in particular military pilots, can also suffer from colour vision disorders caused by physical influences. The pilots are faced with exceptionally bright environmental illumination which can arise in the cockpit and which may continually and rapidly change during flying manoeuvres, thus affecting the perception of colours in the various cockpit displays. Conditions that produce direct or reflected dazzle may lead to visual disability. Coloured light exposure at high intensity (laser light dazzling) may make reading of instruments and colour displays impossible.

The effects of such dazzle may lead to the development of strong after-images (usually in complementary colours), which means that certain colour signals and signs cannot be recognised during variable length recovery times.

The formation of after-images when wearing night-vision goggles may be of concern since such images could lead to alterations in colour perception. Furthermore, equipment such as laser eye protective goggles and visors also have an influence on colour perception depending on the filtering effect involved. In certain cases, particular colours may be invisible since they are completely removed from view by filtering.

While colour sense disorders acquired through illness are seldom found in pilots, the danger of colour vision disorders caused by physical influences, particularly during wartime operations, must be accepted as being ever present.

### 5.4 DRUG-INDUCED COLOUR VISION SIDE EFFECTS

#### 5.4.1 General Principles

All drugs, whether systemically or topically administered, may have ocular side effects. A particular group of medications is known to affect colour vision and is included in Table 5.3 at the end of this chapter.

These side effects usually produce a disturbance of the red-green or the blue-yellow chromatic system. In addition objects in the visual field may have a coloured tinge; usually blue, brown, green, red, violet or purple. White lights may seem to have chromatic haloes. Although in some cases colour vision effects are other than the ones described, many are unique and associated with certain medications.

In general terms, these effects are transient, reversible, usually rare and of little clinical significance, with the exception of a few that produce long-lasting and profound disturbances. Many of these are dose related and diminish and disappear after the causative medication is withdrawn.

#### 5.4.2 Medications

Medications that disturb colour vision may be included in the following categories. Acquired colour vision deficits have been categorised by

means of a system devised by Verriest (1963). They are shown in the column labelled Deficit Type (Table 5.3). Although not designed for that purpose, the system is often used to characterise colour vision errors due to drug effects. The system is repeated here for convenience in viewing Table 5.3.

TYPE I - a red-green deficit characteristic of retinal pathology in the posterior pole macula where there are only "red" and "green" cones. There is an accompanying loss of visual acuity. The disease may progress to total colour blindness and a nearly complete loss of visual acuity.

TYPE II - a red-green deficit with an accompanying milder loss of blue-yellow sensation. This problem is seen when there is optic nerve involvement as is seen in optic neuritis, retrobulbar neuritis, optic atrophy, optic nerve intoxication, or in tumours of the optic nerve or chiasm.

TYPE III - a blue-yellow deficit which is, by far, the most common acquired colour vision defect. It occurs in choroidal, pigment epithelial, retinal and neural disorders including nuclear cataract, chorioretinal inflammations and degenerations, vascular disorders, glaucoma and many others.

### 5.4.3 Testing Procedures for Acquired Colour Vision Defects

The following tests have been described in Chapter 4 and practical considerations have been detailed in Appendix 2. In general, those tests used with hereditary diseases may be used to assess acquired deficits. Please refer to those two sections for details of test strategy, administration and scoring.

The following list indicates those instruments that are known to work well when evaluating an acquired colour vision problem. It is often the case, that more than one metric is needed to obtain a diagnosis. Screening, however may be done by means of the PIP plates.

PIPI (traditional) – screens for red-green defects.

PIPII (SPP-II) – screens for blue-yellow acquired defects.

PIPIII (SPP-III) – Combination of PIPI and PIPII screens for red-green and blue-yellow acquired defects.

Panel D-15 – screens for protan, deutan and tritan dichromacies.

FM-100 – assesses hue discrimination for protan, deutan and tritan defects. Results are quantitative and amenable to statistical manipulation.

Lanthony New Colour Test – identifies neutral points and tests chromatic discrimination.

Rayleigh match – Nagel anomaloscope and Spectrum Colour Vision Meter – detects red-green colour vision "weaknesses".

Moreland match – Spectrum Colour Vision Meter – detects blue-yellow colour vision "weaknesses".

## 5.5 REFERENCES

1. Aronson, J.K. and Ford, A.R., The use of colour vision measurement in the diagnosis of digoxin toxicity, *Q. J. Med.*, 49:273, 1980.
2. Arruga, J., Test of subjective desaturation of color in diagnosis of effect of ethambutol on anterior optic neuropathy, *Bull. Soc. Ophthalmol. Fr.*, 82:182, 1982.
3. Birch, J., et al, Acquired color vision defects. In Pokorny J. et al (Eds) Congenital & Acquired color vision defects, New York, Grune & Stratton, 1979, p 243.
4. Bovino, J.A. and Marcus, D.F., The mechanism of transient myopia induced by sulfonamide therapy, *American Journal of Ophthalmology*, 94:99, 1982.
5. Dekking, H.M., Visual disturbances due to tridione, *Acta Cong. Ophthalmology*, 1:465, 1950.
6. Dyson, G.H. et al., Death and blindness due to overdose of quinine, *British Medical Journal*, 291:31, 1985.
7. Fisher, C.M., Visual disturbances associated with quinidine and quinine, *Neurology*, 31:1569, 1981.
8. Fraunfelder, F.T., Interim report: National registry of Drug-Induced Ocular Side Effects, *Ophthalmology*, 86:126, 1979.
9. Fraunfelder, F.T., Interim report: National registry of Drug-Induced Ocular Side Effects, *Ophthalmology*, 87:87, 1981.

10. Fraunfelder, F.T. and Meyer, S.M., Amiodarone, In : Drug-Induced Ocular Side Effects and Drug Interactions (3rd Ed), 25, Lea & Febiger, London, 1989, p 244.
11. Fraunfelder, F.T. and Meyer, S.M., Chlortetracycline, In : Drug-Induced Ocular Side Effects and Drug Interactions (3rd Ed), 25, Lea & Febiger, London, 1989.
12. Fraunfelder, F.T. and Meyer, S.M., Epinephrine, In : Drug-Induced Ocular Side Effects and Drug Interactions (3rd Ed), 25, Lea & Febiger, London, 1989, p 314.
13. Fraunfelder, F.T. and Meyer, S.M., Ethanol, In : Drug-Induced Ocular Side Effects and Drug Interactions (3rd Ed), 25, Lea & Febiger, London, 1989, p 137.
14. Fraunfelder, F.T. and Meyer, S.M., Isocarboxazid, In : Drug-Induced Ocular Side Effects and Drug Interactions (3rd Ed), 25, Lea & Febiger, London, 1989, p 111.
15. Fraunfelder, F.T. and Meyer, S.M., Naproxen, In : Drug-Induced Ocular Side Effects and Drug Interactions (3rd Ed), 25, Lea & Febiger, London, 1989, p 171.
16. Godel, V., Nemet, P. and Lasar, M., Chloramphenicol Optic Neuropathy, *Archives Ophthalmology*, 98:1417, 1980.
17. Goodman, A.G., Goodman, L.S. and Gilman, A. (Eds), *The Pharmacological Basis of Therapeutics* (6th Ed), New York, McMillan, 1980, p 1222.
18. Hanever, W.H., *Ocular Pharmacology* (5th Ed), St. Louis, CV Mosby, 1983, pp 525-531.
19. Joubert, P.H., et al, Subclinical impairment of colour vision in patients receiving ethambutol, *Br. L. Clinical Pharmacology*, 21:213, 1986.
20. Katz, I.M., Indomethacin, *Ophthalmology*, 88:455, 1981.
21. Lam, R.W. and Remick, R.A., Pigmentary retinopathy associated with low-dose thioridazine treatment, *Canadian Medical Association Journal*, 132:737, 1985.
22. Lamda, P.A., Sood, N.N. and Moorthy, S.S., Retinopathy due to chloramphenicol, *Scottish Medical Journal*, 13:166, 1968.
23. Melgaard, B., The neurotoxicity of ethanol, *Acta Neur. Scand.*, 67:131, 1983.
24. Pokorny, J., Smith, V., Verriest, G. and Pinkers, A.J.L.G., Congenital and acquired color vision defects, New York, Grune and Stratton, 1979.
25. Rietbrock, N. and Alken, R.G., Color vision deficiencies: A common sign of intoxication in chronically digoxin-treated patients, *J. Cardiovasc. Pharmacology*, 2:1568, 1981.
26. Salamon, S.M., Tetracycline in Ophthalmology : *Survey Ophthalmology*, 29:265, 1985.
27. Sloan, L.L. and Gilger, A.P., Visual effects of tridione, *American Journal of Ophthalmology*, 30:1387, 1947.
28. Tulio, C.J., Ibuprofen-induced visual disturbance, *American Journal of Hospital Pharmacology*, 38:1362, 1981.
29. Verriest, G., Further studies on acquired deficiency of color discrimination, *Journal of the Optical Society of America*, 53:185, 1963.
30. Walsh, F.B. and Hoyt, W.F., In *Clinical Neuro-ophthalmology* (3rd Ed), Baltimore, Williams & Wilkins, Vol III, 1969, pp 2558-2560.

Table 5.2: Acquired colour vision defects excluding those from physical agents

CATEGORY	Blue-Yellow	Red-Green
<b>Ageing</b>	* (most influenced)	* (green shift)
<b>Retinal Detachment</b>	*	
<b>Pigment Epithelial Detachments</b>		
Central serous retinopathy	*	*
Optic pit serous detachments	*	*
<b>Hereditary Vitreoretinal Degenerations</b>		
Sex-linked recessive	*	*
Wagner's syndrome	*	
Goldman-Favre	*	
<b>Diffuse Chlorioretinal Dystrophies</b>		
Retinitis pigmentosa	*	* (small)
Atypical retinitis pigmentosa (Inverse, sector, etc.)	*	*
Retinitis punctata albescens	*	*
Choroideremia	*	*
Gyrate atrophy		*
Ceroidlipofuscinosis		*
<b>Cone Dystrophy</b>		*
<b>Macular Dystrophies</b>		
Stargardt's		*
Fundus flavimaculatus	* (rare)	*
Dominant drusen	*	* (rare)
Butterfly dystrophy		*
Malignant myopia	*	*
Sorsby's dystrophy	*	*
Choroidal dystrophy (central areolar)	* (rare)	*
Pattern dystrophy of the pigment epithelium	* (mild)	*
<b>Other Macular Degenerations</b>		
Senile macular degeneration	*	*
<b>Secondary Macular Degenerations</b>		
Angioid streaks	* (in severe disease)	*
<b>Vascular and Haematologic Diseases</b>		
Addison's anaemia	Violet, blue and green sensitivity losses	
Systemic hypertension and atherosclerosis		*



Table 5.2 continued: Acquired colour vision defects excluding those from physical agents

CATEGORY	Blue-Yellow	Red-Green
<b>Local Vascular Occlusive Diseases</b>		
Retinal artery occlusion		* (pre-existing)
Choroidal arterial occlusion		*
<b>Diabetes</b>		*
<b>Inflammatory Chorioretinal Diseases</b>		
Choroiditis	* (early)	*
Pars planitis		*
<b>Inflammation of the Retinal Pigment Epithelium</b>		
Acute multifocal posterior placoid pigment epitheliopathy		*
Serpiginous and geographic choroidopathy	diffuse errors with no axis	
<b>Inflammation of the Retina</b>		
Retinitis	various combinations of defects	
<b>Glaucoma</b> (including ocular hypertension and glaucoma)	*	*
<b>Visual Pathway and Higher Centre Disorders</b>		
Optic Nerve Disorders		
Leber's optic atrophy	*	
Autosomal dominant optic atrophy	* (rare)	*
Behr's optic nerve atrophy	*	
Acute optic neuritis	*	*
Chronic optic neuritis	*	*
Ischemic optic neuropathy		*
Papilledema		*
Optic Chiasm Disorders		
Anterior chiasmal syndrome	generalised sensitivity loss	
Chiasmal syndrome	*	*
Optic Tract and Optic Radiation Disorders	*	
<b>Visual Cortex and Higher Cortical Centres</b>		
Visual cortex		*
Higher cortical centres	loss of wavelength discrimination, colour blindness, colour agnosia (can't name colours), other bizarre consequences of stroke as related to colour perception, fluctuations in sensitivity, hue discrimination range expands resulting in extremely poor performance	

Table 5.3: A group of medications known to affect colour vision

DRUG	CHROMA-TOPSIA <sup>1</sup>	DEFICIT TYPE	TINGE OR HALO	NOTES
<b>Analgesics</b>				
Acetaminophen			yellow	
Salicylates	+	I	yellow	
<b>Antibiotics</b>				
Chloramphenicol		II	yellow	Total dose > 100g or > 6 weeks
Chlortetracycline		III		The only tetracycline that affects colour vision
Erythromycin		III	red, green	
Ethambutol		II, III		For 3-6 months, defect persists
Ethionamide				Heightened colour perception
Isoniazide		II		
Penicillamine		II		
Streptomycin	+	II	yellow	
Sulfonamides	+	II	red, yellow	Transient myopia
Salazosulapyridine		I		
<b>Antifungal</b>				
Griseofulvin			green	
<b>Antipyretics</b>				
Ibuprofen		II		Colours appear faded
Phenylbutazone		II		
Salicylates	+	I	yellow	
<b>Antimalarials</b>				
Atabrine	+			
Chloroquine	+	III +	yellow	Purple spots (white background)
Clioquinole		II+, III		
Quinidine		II		
Quinine	+	I, II, III		
<b>Antineoplastics</b>				
Mercaptopurine		II		
Vincristine		II		
<b>Antirheumatics</b>				
Ibuprofen		II		Colours appear faded
Indomethacin		III		
<b>Antispasmodics</b>				
Atropine			red	Ocular administration
<b>Cardiac and Vascular</b>				
Amiodarone			halo	Glare from lights
Ergotamine	+	II	red	
Nitroglycerin			halo blue, yellow	
Rawolfia alkaloids			yellow	Mainly reserpine
Digoxin		III	halo blue, red, yellow, green	Blue-yellow is early toxicity indicator
Digitalis	+	I+,II,III		

<sup>1</sup> Visual defect in which colourless objects appear to be tinged with colour.

Table 5.3 continued: A group of medications known to affect colour vision

DRUG	CHROMA-TOPSIA	DEFICIT TYPE	TINGE OR HALO	NOTES
<b>CNS effects</b>				
Alcohol (ethanol)	+	II	halo blue	
Alcohol (amyl)	+	II		
Amphetamines			blue	
Barbiturates	+			
Isocarboxazid				
Methaqualone		I,II,III	yellow	
Oxazolinediones				Prolonged dazzle in light, objects seem
Pentobarbital			green, yellow	
Pentylentetrazol			yellow	
Phenothiazides			halo blue, yellow	Rare in low doses
<b>Diuretics</b>				
Thiazides			yellow	Yellow spots in white field
Chlorothiazide	+	II		
<b>Gases</b>				
Carbon dioxide			yellow	
<b>Ganglionic blockers</b>				
Hexamethonium		III		
<b>Heavy Metals</b>				
Arseniacals	+	II		
Cyanide		II		
Lead		II		
Strychnine	+			
Thallium		II		
<b>Hormones</b>				
Oral contraceptives		II	halo, blue	
<b>Nitrofurane deriv.</b>				
Furaltodone		I,II ?		
Nalidixic Acid	+			
<b>MAO inhibitors</b>				
<b>Metal antagonists</b>				
Disulfiram		II	Red, green	
<b>Phenothiazine deriv.</b>				
Thioridazine	+	I		
<b>Tuberculostatics</b>				
Dihydrostreptomycin		II		
Ethambutol		II, III		For 3-6 months, defect persists
Isoniazide		II		
PAS		II		
Rifampin	+	II		
Streptomycin	+	II	yellow	
<b>Miscellaneous</b>				
Cannabis indica	+			
Tobacco (amblyopia)		II,III +		
Sildenafil citrate (Viagra)	+	II,III	Blue, blue-green, yellow, pink	Flashing lights, photophobia; defects reversible so far

**This page has been deliberately left blank**



**Page intentionnellement blanche**

## Chapter 6

### A Review of NATO Aviation Colour Vision Testing Methodologies and Standards

Douglas J. Ivan, Beatrice LeBail and Franz-Josef Daumann

Colour vision methodology employed within the NATO Alliance is variable. All countries employ red-green testing on entry, but not all re-administer red-green testing later in an aviator's career. Similarly, only a minority of NATO countries test for blue-yellow deficits either on entry or on later evaluations.

Testing utilised in NATO can be categorised into: colour plate tests, lanterns, cap tests, diode tests and anomaloscopes.

The complete listing of tests utilised by each individual country is available in Table 6:1: NATO Aircrew Colour Vision Tests. The majority of nations utilise a form of the ISHIIHARA pseudo-isochromatic plates (PIP) test for red-green testing either on entry or for periodic retesting. All but three NATO countries routinely retest colour performance later on in an aircrew member's flying career.

#### 6.1 BELGIUM

The Belgian Army and Air Force use the same colour testing methodology. The Air Force categorises its crew positions into Student Pilot, Student Navigator, Trained Jet Pilot, Trained Non-jet Pilot, Navigator and Flight Engineer. The Belgian Army categorises its aircrew as Student Pilot, Trained Pilot, and Flight Engineer. Colour vision testing applies to all such crew positions. Such testing is administered at entry, annually, and if acquired pathology indicates retesting. The ISHIIHARA version of the PIP plates is used at entry and must be passed without errors. If any errors are recorded, then the Nagel anomaloscope is administered. The AO HRR plates may be substituted for the ISHIIHARA. Similarly, if there are any errors on this version of the plate test, the Nagel anomaloscope is administered. When tested with the Nagel anomaloscope, the subject must pass with a score of 0.67 - 1.25 and is disqualified if the scoring exceeds this range and is not eligible for waiver. However, if a trained aircrew member

acquires a colour deficit and subsequently fails the Nagel, a waiver may be considered for continued flying duties on a case-by-case basis.

#### 6.2 CANADA

Canada categorises its military aircrew into categories based on colour performance: CV1 - Colour Vision Normal, CV2 - Colour Vision Safe and CV3 - Colour Vision Unsafe. CV2 is the minimum entry standard for Pilot, Navigator, Air Traffic Controller (ATC), S&R Specialist, Tac Helo Observer, Loadmaster, Flight Engineer, and Flight Nurse. CV3 is the minimum entry standard for Cabin Personnel, Flight Surgeon, AMTO, AWACS, and Parachutist. All three categories are initially administered the 38-plate ISHIIHARA test for entry qualification. Three or less errors categorises the applicant as CV1, otherwise greater than 3 errors warrants retesting with other tests. Pilots and navigators who fail the ISHIIHARA are immediately tested with the Holmes-Wright or Farnsworth (FALANT) lanterns. Any other crew position or applicant who fails the ISHIIHARA are first administered the D-15. If they pass the D-15, they are regarded as CV2. If they fail the D-15, they are then administered the Holmes-Wright or FALANT. If they pass the lantern test, they are categorised as CV2 whereas if they fail, they are categorised as CV3. On testing with the Holmes-Wright lantern, if a testee has no errors on the first trial, they are categorised as CV2. Should one or more errors occur, a retest is administered. If that applicant achieves no errors on the second trial, then they are similarly regarded as CV2 qualified. However, if there is one or more errors on the second trial, then they are regarded as CV3 and disqualified for all operational aircrew cockpit positions. Canada has no policy requiring the retesting of colour vision on a periodic basis. However, retesting of aircrew using the ISHIIHARA PIP plates during annual physical examination does occur sporadically. Waivers may be considered for trained CV3 non-pilot aircrew on a case-by-case basis.

### 6.2.1 The Civil Aviation Administration (CAA) (Canada)

The CAA categorises civil pilots into four categories:

- I - Commercial Pilots;
- II - Air Traffic Controllers, Flight Navigators, and Flight Engineers;
- III - Private Pilots and Ultralight Aircraft Pilots; and
- IV - Other Private Pilots and Glider Pilots.

For Category I, several test options may be utilised. The 18-plate AO pseudo-isochromatic plates are passed by scoring no more than three errors. The 16-plate ISHIIHARA is passed by scoring no more than one error on plates 1-8. The 24-plate ISHIIHARA is passed by scoring no more than two errors on plates 1-15. The 36-plate ISHIIHARA is passed with no more than three errors on plates 1-21. The 20-plate AO HRR, 2nd Edition, is passed if there are no errors on plates 1-6. Several additional tests may be substituted to include the Titmus colour test without any errors, the Keystone Orthoscope with no more than two errors, or the Telebinocular test with no errors. If a Category I pilot fails any one of these three alternate tests, they then must be re-tested with the plate tests listed above. For categories I, II, and III, if the colour test is failed, a waiver may be considered if the pilot passes the Canadian Forces colour test battery or the Civil Aeronautics Colour Perception Lantern Test. If a pilot fails these back-up tests, he may still be considered for waiver, if he passes a practical colour test under operational conditions. Should he fail the operational colour test, he may still be considered fit for commercial aviation, if he can demonstrate proficiency in perceiving red-green and white on the Canadian Forces colour test battery, but would only be allowed to fly under daylight-normal and two-way radio communication conditions. Colour testing is repeated annually for civil aviation commercial pilots.

### 6.3 DENMARK

Denmark classifies its aircrew members as: Student Pilot, Student Navigator; Trained Aircrew; and other Non-pilot crewmembers not in primary control of aircraft. Denmark uses ISHIIHARA pseudo-isochromatic plates on entry and requalification or as required when associated with

acquired pathology. Trained aircrew, student pilots, student navigators, air traffic controllers, and radar operators must pass the ISHIIHARA without any errors. If failed, student pilots and student navigators must pass the Holmes-Wright lantern test and the Nagel anomaloscope for entry into further training. Trained aircrew are also tested at periodic intervals using the same three tests. They are retested every 4 years if under age 40 and every 3 years after that. At the time of publication, Denmark is planning to implement blue-yellow testing as well.

### 6.4 FRANCE

France categorises its aircrew similarly for all three service branches. Furthermore, each of these categories is broken down into three colour vision based performance categories: SCA/1, SCA/2, and SCA/3. To meet SCA/1 standards, aircrew that qualify must pass the ISHIIHARA pseudo-isochromatic plates without any errors. This test is administered on entry and on annual re-evaluation. The ISHIIHARA plate test is used in all three services, with the only difference being the amount of presentation time allowed for each plate: Air Force (0.25 sec); Navy (1.00 sec); Army (1.00 sec). Failure to pass the ISHIIHARA test results in disqualification without waiver. To meet SCA/2 standards, aircrew must be able to pass the ISHIIHARA without error, or if they fail the ISHIIHARA, one or more errors, they then must pass the Beynes Lantern without error. Any error on the Beynes Lantern test results in disqualification without waiver. This test is administered at entry and on annual re-evaluations for the appropriate aircrew category. SCA/3 is reserved for individuals who fail both the ISHIIHARA and the Beynes Lantern and is unassigned any functional crew responsibilities. SCA/1 standards must be met by pilots and candidate pilots; navigators and candidate navigators; gunners and candidate gunners; radar operators and candidate radar operators. SCA/2 standards must be met by flight engineers, radio navigators, observers, radio operators, air traffic controllers, flight refuelers, light aircraft pilots, reserve military pilots and candidates for any of these categories. If an aircrew member fails either of the qualifying tests for the appropriate category, more comprehensive colour evaluation will include the FM-100, Nagel anomaloscope, and Besancon anomaloscope. However, these tests are administered to identify the pathological process

and will not be waivable into either SCA/1 or SCA/2 categories.

## 6.5 GERMANY

The German Armed Forces categorises its aircrew into Class 1 - Candidate Pilot and Student Pilot in the first part of training; Class 2 - Trained Pilot and Student Pilot in the second part of training; and Class 3 - Navigator and other personnel not in primary control of the aircraft. On entry and annual examinations, the ISHIHARA (red-green) and Stilling-Velhagen (blue-yellow) PIP plates are used for all categories. All categories must pass these PIP tests and if a failure occurs candidates then undergo more comprehensive colour vision testing to include the Nagel anomaloscope.

When tested with the anomaloscope, the candidate must achieve a score of between 0.7 - 1.4. Should they exceed this test score, they are disqualified without waiver, with the exception of navigators and other personnel not in primary control of aircraft, which may be considered for a Class 3 waiver. In some cases, the Rodenstock, Stilling-Velhagen, and Kampeter test have been utilised to further assess the colour deficiency. Commercial pilots are categorised into 2 categories: Class I and II. These pilots must pass the plates, but if these are failed, waiver may be pursued based on Nagel anomaloscope scores.

## 6.6 GREECE

Greece categorises its aircrew positions into: Student Pilot, Pilot, Navigator, and Observer. All categories must pass the AO pseudo-isochromatic plates on entry and must correctly identify 10 or more of the 14 plates. Failure of this testing is disqualifying. A trained pilot and navigator is also administered the AO plates on an annual basis and must correctly identify 10 or more plates correctly out of 14, otherwise they are also disqualified.

## 6.7 ITALY

Italy administers the ISHIHARA plate test on entry and annual examination of pilots and navigators. Failure of the ISHIHARA test results in disqualification. Other aircrew personnel (not pilot or navigator) are administered the Nagel anomaloscope on entry and annually. If they fail the Nagel anomaloscope, they are administered the Beynes Lantern. The Beynes Lantern will then be

administered annually. Failure of the Beynes Lantern results in disqualification.

## 6.8 THE JOINT AVIATION REQUIREMENTS (JAR)

The JAR requirements categorises its aircrew into Class I and II based on refractive error. Applicants in either category are administered the ISHIHARA plate test and must correctly identify all plates. Failure of this test warrants retesting with the Nagel anomaloscope. Passage of the Nagel anomaloscope occurs with less than 4-scale unit differential. However, if the Nagel is failed, then either the Beynes, Holmes-Wright or Spectrolux is administered in order to determine if the applicant is "colour safe". To achieve the category of "colour safe", an applicant must pass either of these three tests without errors. The ISHIHARA is also administered to already trained crewmembers on renewal basis.

## 6.9 NETHERLANDS

The Netherlands categorises its aircrew positions into Ia - Candidate Jet Pilot, Student Jet Pilot; Ib - Trained Jet Pilot; IIa - Candidate Helicopter, Student Helicopter, Candidate Flight Engineer (Board Mechanic), Air Photographer, Search and Rescue Technician Candidate; IIb - Helicopter Pilot, Board Mechanic (Flight Engineer), Search and Rescue Technician; III - Transport Pilot; and IV - Air Photographer, Board Mechanic (Flight Engineer), Flight Surgeon, Nurse, Cabin Attendant, and Hyperbaric Chamber Personnel. All categories are tested on entry and on annual retesting using the ISHIHARA 16-plate test. A passing score for this test is correctly identifying 11 out of 16 plates. Failure of the initial ISHIHARA plate test, results in retesting using the Holmes-Wright Lantern. However, an applicant or trainee must pass the Holmes-Wright Lantern without any errors. In trained flying categories, slight deuteranomaly may be permitted on a case-by-case basis.

## 6.10 NORWAY

Norway categorises their aircrew into: A1 - Pilot; A2 - Student Pilot, Pilot with medical restrictions, and A3 - All other aircrew. Norway administers the 38-plate version of the ISHIHARA pseudo-isochromatic plates on entry and on retesting of all aircrew. Retesting occurs every six years if under

the age of 40, and every 3 years thereafter. To pass the ISHIHARA test, a testee must correctly identify all 38 presentations otherwise they are disqualified. Norway has dropped the FALANT as an ancillary qualifying test.

## 6.11 PORTUGAL

Portugal categorises its aircrew as TG - Applicant (any category); TC1 - Pilot; TC2 - Navigator and Radar Operator; and TC3 - Weather Specialist and Ground Crew. All applicants are tested on entry and annually with the ISHIHARA plates and must pass the screening tests. If a failure occurs, they are retested using the Beynes Lantern. If the Beynes Lantern test is failed, the FM-100 is administered. If the applicant fails the FM-100, they are disqualified for entry or continued flying duties.

## 6.12 SPAIN

Spain categorises its aircrew into: Group 1 - Pilot (candidate, trained pilot); Group 2 - Non Pilot, and Paratrooper (candidate, trained); and Group 3 - Controller (candidate, trained).

All aircrew (Groups 1,2,3) must pass the ISIHARA on entry and annually without any errors. In addition, all pilot candidates are administered the Beynes Lantern. A failure of the ISHIHARA plates also warrants retesting using the Beynes Lantern. If they fail the Beynes Lantern, then they are disqualified and the FM-100 test is administered for assessment only. To pass the Beynes Lantern, Groups 1 and 3 must pass both the pure and combined colours whereas Group 2 is only required to pass the pure colours.

## 6.13 TURKEY

The Turkish Armed Forces use the ISHIHARA pseudo-isochromatic plates for all aircrew categories: Student Pilot, Pilot, Navigator, and Weapon Systems Operator. Testing is administered on entry and annually. To pass the test, no errors are permitted. Failure of the test is disqualifying without waiver on entry, or annually, below the rank of Major. Waiver will be considered for trained aircrew, the rank of Major or above.

## 6.14 UNITED KINGDOM

The United Kingdom categorises its aircrew positions into: CP1 - Royal Navy Pilot (Colour

Normal, Critical Tasks); CP2 - RAF/Army Pilot, Fighter Control Trades, Navigator, Air Traffic Controller and all other RAF aircrew (Colour Normal); CP3 - AF, Cabin Personnel, (Colour Defective, Safe); and CP4 - (Colour Defective, Unsafe). The Royal Navy first administers the Holmes-Wright Lantern and candidates must pass without error at low brightness to achieve CP1. They are then tested with the ISHIHARA if they fail the lantern. The Royal Air Force and Royal Army first administer the ISHIHARA plates. To achieve a rating of CP2, an applicant must pass all of the plates without error. If an error occurs, they are then administered the Holmes-Wright Lantern. If they pass this test under high brightness test conditions, they are still categorised as CP3. However, if they fail, they are categorised as CP4 and are disqualified.

## 6.15 UNITED STATES

### 6.15.1 US Air Force (USAF)

The USAF categorises aircrew and related personnel into: FCI - Student Pilot; FCIA - Student Navigator; FCII - Trained Pilot, Navigator, and Flight Surgeon; FC II Initial - Flight Surgeon Applicant; FCIII - All other aircrew categories not in primary control of aircraft; and ATC - Air Traffic Controller. All applicants are administered a 14-plate pseudo-isochromatic plate test (red-green test) and must pass the test with a score of 10 or more correctly identified out of 14 plates. In addition, all pilot applicants are administered the Farnsworth F2 Plate and the new Standard Pseudo-isochromatic Plates (SPP) II and III to assess blue-yellow colour vision. Several different red-green PIPs are approved for use and include the Dvorine, ISHIHARA, or original version of the AO. [Note: The Richmond PIP are no longer used because of printing irregularities.] The USAF has officially discontinued using the FALANT as a back-up qualifying test if an applicant fails the PIP. The Colour Threshold Test (CTT) was previously abandoned because of variable fading of the coloured filters used by this test. A comprehensive battery of colour vision tests are administered at the Aeromedical Consultation Service of the USAF School of Aerospace Medicine at Brooks AFB to categorise and quantify any colour deficiency. The USAF currently tests its aircrew at entry level only and does not retest during subsequent evaluations unless symptomatology indicates or suggests that these tests are required. Blue-yellow screening



tests are administered to all pilot applicants to establish baselines and to screen for acquired colour vision deficits. In addition, it has also been recommended that red-green and blue-yellow colour vision testing be re-administered routinely to trained aircrew and air traffic controllers, either annually or at least every 3 years. This recommended change in the policy is pending and has not yet been approved at the time of publication of this report.

### 6.15.2 US Army (USA)

The US Army defines its aviation categories into FC1 - Warrant Officer Student; F1A - Commissioned Officer Student; and FC2 - Trained Pilot, Student Pilot after starting training, and Flight Surgeon. The same colour standards also apply to Air Traffic Controllers. All categories must pass the ISHIHARA PIP plate test on entry and must do so with a qualifying score of 10 or more correctly identified out of 14 presentations. If they fail this test, the FALANT is administered. They must pass the FALANT by identifying 9 for 9 correctly or in the event of one error, will be re-administered the FALANT but must score correctly 16 out of 18 presentations on the second run, otherwise they are disqualified.

### 6.15.3 US Navy (USN)

The USN categorises its aviators into: SNA - Student Naval Aviator (pilot); SNFO - Student Naval Flight Officer (navigator/system weapon officer); and SNFS - Student Naval Flight Surgeon. Trained pilots are classified into performance categories: SG1 - Unlimited Pilot Duties; SG2 - No shipboard pilot duties except for rotary aircraft; and SG3 - Dual control aircraft with other SG1 or SG2 pilot in attendance. The USN categorises its other trained aircrew into NFO - Naval Flight Officer and NFS - Naval Flight Surgeon. Colour vision testing is administered on entry and annually. A pseudo-isochromatic plate (PIP) test is now administered to all aviation categories including Air Traffic Controllers. Applicants must correctly identify 12 out of 14 plates to pass. Failure of the PIP results in administration of the FALANT with 9/9 considered passing. If one error is made on the initial run, then it is re-administered two more times and to pass, the applicant must score 16 correct out of 18. The FALANT is administered to all categories including Air Traffic Controllers

only if they fail the PIP. The FALANT is strictly a red-green test and by design passes 30% of colour defectives (mild anomalous trichromats).

### 6.15.4 The Federal Aviation Administration (FAA)

The Federal Aviation Administration (FAA) in the United States recognises three classes of medical certification applicable to civilian aviation. First-class: Air Transport Pilot; Second-class: Commercial Pilot, Flight Engineer, Flight Navigator, Air Traffic Control Tower Operator; and Third-class: Private Pilot and Student Pilot. Glider and free balloon pilots are not required to hold a medical certificate of any class. However, they are required to certify whether they have any known medical defects that would make them unable to pilot a glider or free balloon. The First-class or ATR rating applies to commercial aviation and is valid for six calendar months. First-class certificate holders must have normal colour vision. Second-class and Third-class must have the ability to distinguish aviation signal red, aviation signal green and white. The colour test equipment required by the FAA are the pseudo-isochromatic plates. It specifies the American Optical Company, 1965 edition (AOC-HRR, 2nd edition); Dvorine, 2nd edition; ISHIHARA, 14, 16, 24, or 38-plate editions; or Richmond, 1983, 15-plate edition. Acceptable substitutes are listed as Farnsworth Lantern, Keystone Orthoscope, Keystone Telebinocular, the OPTEC 2000, the Titmus Vision Tester and the Titmus II Vision Tester.

For First-class certificates, the applicant or crew member is disqualified, if they fail the colour plates or the suitable alternative. They may be allowed a conditional limitation to continue to fly with a certificate not valid for night flying or by colour signal control. Failure of testing can result in an FAA authorised signal light or medical flight test, as required, in order to determine ability to fly.

Air Traffic Controllers are divided into two categories: Governmental and Contract. Governmental controllers are tested only on initial application with the Dvorine plates and must score 12 out of 14 correct. Failure of the Dvorine can result in a FAA authorised signal light or operational test for potential waiver. Contract controllers must pass a Second Class FAA exam, as listed above, which basically demonstrates the

ability to distinguish aviation red, green, and white. A signal light test is acceptable, but no waivers are considered, if this test is failed. All FAA testing, however, is red-green in nature. There is no blue-yellow screening required.

## 6.16 CONCLUSION

An overall analysis of current NATO colour vision testing methodology reveals that **all NATO countries test at entry for red-green deficiencies. However, blue-yellow testing is not routinely administered by the majority.** Over 26 different tests are currently utilised by member nations (Table 6.1).

**Nearly all NATO countries routinely retest colour vision in aircrew members.** Norway, Denmark, and the Netherlands base the retest interval on age. However, the UK and the US, with the exception of the US Navy, only administer entry level colour vision testing and do not currently retest trained aircrew. Canada often retests colour vision, but has no formal policy that requires it. Most countries, however, do follow-up comprehensive diagnostic colour methodology if aircrew are identified to have developed colour vision disturbances.

**Currently, the minority of NATO countries administer comprehensive blue-yellow assessment either at entry or on re-evaluation.**

**Most countries rely on pseudo-isochromatic plates (PIP) to establish red-green proficiency at entry and only utilise other tests if the initial qualification PIP test is failed. Thus, all countries rely on red-green testing, but most do not routinely evaluate for blue-yellow performance either at entry or on requalification. However, several additional countries are planning to implement blue-yellow testing shortly and others currently have it under consideration or review.**

Table 6.2: Frequency of Colour Vision Testing in Aircrew, addresses the administration of colour vision testing as per entry and requalification frequency on a country-by-country basis.

Table 6.3: Colour Vision Testing Methodology by Country, addresses the testing methodology in greater detail used by NATO countries.

Thus, it appears that the complexity of the modern cockpit and its reliance on full colour spectral sensitivity, target discrimination, as well as occupationally derived threats, to include medication and potential occupational hazards such as lasers, are not operationally supported by colour vision testing methodology that tests for full spectral capability in the majority of cases nor repeated at a frequency that is likely to identify typical acquired colour vision deficiencies.

**Specifically, although congenital blue-yellow defects are very rare, acquired blue-yellow defects are much more common and can be commonly associated with acquired pathology or medication effects and (with some exceptions) are not routinely or adequately tested for by all members of the NATO community. However, acquired pathology that would induce red-green colour vision deficiencies is currently retested for on a routine basis in all, but three countries, by virtue of retesting with a red-green colour vision test.** It should be noted, however, that most acquired colour vision deficiencies more typically start as a blue-yellow colour vision disturbance.

Although most countries utilise some form of pseudo-isochromatic colour plate (PIP) testing, there is **little consensus as to the type and scoring of the PIP tests.** Similarly, there is not a consensus on the subsequent testing methodology that is employed should an individual fail the initial screening plate tests.

**Thus, there appears to be a reasonable requirement for universal NATO recommendations regarding colour vision testing and retesting methodology that would maximise aircrew colour performance, enhance interoperability, and optimise the biological coupling between aircrew and the colour vision requirements of the modern cockpit. Such recommendations will be presented at the conclusion of this technical report.**

Table 6.1: NATO Aircrew colour vision tests

NAME (MANUFACTURER)	COUNTRY*	TYPE	DEFICIENCY DETECTED
ISHIHARA (16,24,38 plates)	(B) (C) (D) (F) (GE) (I) (JAR) (NE) (N) (P) (S) (T) (UK) (US)	Colour Confusion/Plate	Red-green (protan/deutan)
AO HRR	(B)	Colour Confusion/Plate	Red-green; blue-yellow (protan/deutan/tritan)
DVORINE	(US)	Colour Confusion/Plate	Red-green (protan/deutan)
RICHMOND	(US)	Colour Confusion/Plate	Red-green (protan/deutan)
AO	(GR)	Colour Confusion/Plate	Red-green (protan/deutan)
STILLING-VELHAGEN	(GE)	Colour Confusion/Plate	Red-green; blue-yellow (protanope/deuteranope/ tritanope)
PIP II (SPP II)	(US)	Colour Confusion/Plate	Blue-yellow (minimal red-green)
PIP III (SPP III)	(US)	Colour Confusion/Plate	Red-green; blue-yellow
FARNSWORTH F2	(US)	Colour Confusion/Plate	Blue-yellow
HOLMES-WRIGHT LANTERN	(C) (D) (NE) (UK)	Brightness/Naming	Red-green (protan/deutan)
BEYNES LANTERN	(F) (I) (JAR) (P) (S)	Brightness/Naming	Red-green (protan/deutan); blue-yellow; white
FARNSWORTH LANTERN	(C) (D) (P) (US)	Brightness/Naming	Red-green (protan/deutan)
FARNSWORTH-MUNSELL 100	(D) (F) (GE) (P) (S) (US)	Hue Discrimination/Cap	Red-green; blue-yellow (protan/deutan/tritan)
D-15 SAT	(C) (F) (GE) (US)	Confusion/Cap	Red-green; blue-yellow (protanope/deuteranope/ tritanope)
D-15, UNSAT	(F) (GE) (US)	Confusion/Cap	Red-green; blue-yellow (protanope/deuteranope/ tritanope)
LANTHONY NCT	(US)	Confusion/Cap	Red-green; blue-yellow (protanope/deuteranope/ tritanope)
AQT-6	(US)	Confusion/Diode	Red-green (protan/deutan)
NAGEL I / NAGEL II	(B) (D) (F) (GE) (I) (JAR) (P) (S) (US)	Anomaloscope	Red-green (protan/deutan)
KAMPETER (BOVA)	(GE)	Anomaloscope	Red-green; blue-yellow (protan/deutan/tritan)
SPECTRUM	(US)	Anomaloscope	Red-green; blue-yellow (protan/deutan/tritan)
BESANCON	(F)	Anomaloscope	Red-green
SPECTROLUX	(JAR)	Brightness/Naming	Red-green
RODENSTOCK	(GE)	Brightness/Naming	Red-green; blue-yellow

\* B = BELGIUM, C = CANADA, D = DENMARK, F = FRANCE, GE = GERMANY, GR = GREECE, I = ITALY,  
JAR = JOINT AVIATION REQUIREMENTS, NE = NETHERLANDS, N = NORWAY, P = PORTUGAL,  
S = SPAIN, T = TURKEY, UK = UNITED KINGDOM, US = UNITED STATES

Table 6.2: Frequency of colour vision testing in NATO aircrew

COUNTRY	RED-GREEN		BLUE-YELLOW	
	ENTRY	RE-EVAL	ENTRY	RE-EVAL
NATO				
BELGIUM	+	Annual	+	+
CAA (NON-NATO)	+	Annual	—	—
CANADA	+	Sporadic (Not required)	—	—
DENMARK	+	<40 @ 4 yrs ≥40 @ 3 yrs	+ (*)	+ (*)
FAA (NON-NATO)	+	Annual	—	—
FRANCE	+	Annual	+	+
GERMANY	+	Annual	+	—
GREECE	+	Annual	—	—
ITALY	+	Annual	—	—
JAR (NON-NATO)	+	Annual	—	—
NETHERLANDS	+	<35 annual ≥35 @ 6 mo	—	—
NORWAY	+	<40 @ 6 yrs ≥40 @ 3 yrs	— (**)	— (**)
PORTUGAL	+	Annual	+	+
SPAIN	+	Annual	+	—
TURKEY	+	Annual	—	—
UK	+	—	+ (**)	+ (**)
US ARMY	+	—	—	—
USAF	+	— (**)	+	— (**)
USN	+	Annual	—	—

\* Planning to implement

\*\* Under review

**Table 6.3: Colour vision testing methodology by country**

Country: **BELGIUM**

AIRCREW CATEGORY DESCRIPTION:

**AIR FORCE (BAF)**

- Student Pilot
- Student Navigator
- Jet Pilot
- Non-Jet Pilot
- Navigator
- Flight Engineer

**ARMY**

- Student Pilot
- Pilots (Helicopter, Fixed Wing)
- Flight Engineer

Name of Colour Test	When Administered (Entry/Annual)	Aircrew Category (Pilot/Navigator)	Score (Pass/Fail)	Consequences of Failure (Disqualified/Next Step)
ISHIHARA	Entry/Annual Acquired Deficits	All	Pass (0 errors)	Nagel
AO HRR	Entry/Annual Acquired Deficits	All	Pass (0 errors)	Nagel
NAGEL	Entry/Annual Acquired Deficits	All	Pass (0.67 - 1.25)	Disqualified (No waiver)
	Acquired	Trained	Fail	May be waiverable

**Table 6.3: Colour vision testing methodology by country (cont'd)**

Country: **CANADA**

**AIRCREW COLOUR VISION CATEGORY DESCRIPTION:**

CV1 – Colour Vision Normal

CV2 – Colour Vision Safe; Minimum entry standard for Pilot, Navigator, Air Traffic Controller, S&R Specialist, Tac Helo Observer, Loadmaster, Flight Nurse, Flight Engineer

CV3 – Colour Vision Unsafe; Minimum entry standard for Cabin Personnel, Flight Surgeon, AMTO, AWACS, Parachutist

Name of Colour Test	When Administered (Entry/Annual)	Aircrew Category (Pilot/Navigator)	Score (Pass/Fail)	Consequences of Failure (Disqualified/ Next Step)
ISHIHARA (38 Plate)	Entry/Annual	All Categories	Pass (CV1) 3 or less errors	Pilots/Navigators → Holmes-Wright or FALANT All others → D-15
D-15	Entry/Annual	All Categories except Pilot/Navigator	Pass (CV2)	Holmes-Wright or FALANT
HOLMES-WRIGHT OR FALANT LANTERN	Entry/Annual	All Categories	- No error on first trial (CV2) - No error on second trial (CV2) - One error or more on the 2nd trial (CV3)	- One or more error requires a 2nd retest - CV2 Qualified - Disqualified for all aircrew operational positions

**Table 6.3: Colour vision testing methodology by country (cont'd)**

Country: **DENMARK**

AIRCREW CATEGORY DESCRIPTION: “FC” = FLYING CLASS

- Student Pilot
- Student Navigator
- Trained Aircrew (Either Navigator or Pilot - All Aircraft)
- Non-Pilot Crewmember (Flight Surgeon, Loadmaster, Flight Engineer, Nurse, Radar Operator)
- Air Traffic Controller (ATC)
- High Altitude Parachutist, Ground “Controller” (Forward Air Controller, Radar Operator)

Name of Colour Test	When Administered (Entry/Annual)	Aircrew Category (Pilot/Navigator)	Score (Pass/Fail)	Consequences of Failure (Disqualified/Next Step)
<b>ENTRY ISHIHARA</b>	Entry	Student (Pilot/Navigator) ATC and Radar Operator	Pass (no errors)	Holmes-Wright and anomaloscope
HOLMES-WRIGHT	Entry	Student (Pilot/Navigator)	Pass	Disqualified
NAGEL ANOMALOSCOPE	Entry	Student (Pilot/Navigator)	Pass	Disqualified
<b>RETEST-ACQUIRED (TRAINED) ISHIHARA</b>	Requalification, Acquired Deficit	Trained Aircrew (Pilot, Navigator, ATC, and Radar Operator)	Pass (no errors)	Holmes-Wright and anomaloscope
HOLMES-WRIGHT	Entry	Trained Aircrew	Pass	Disqualified
NAGEL ANOMALOSCOPE	Entry	Trained Aircrew	Pass	Disqualified

**Table 6.3: Colour vision testing methodology by country (cont'd)**

Country: **FRANCE**

AIRCREW CATEGORY DESCRIPTION: (ALL SERVICE BRANCHES)

- SCA/1:
- Pilot (and Student)
  - Navigator (and Student)
  - Gunner (and Student)
  - Radar Operator (and Student)

- SCA/2:
- Flight Engineer
  - Radio Navigator
  - Observer
  - Radio Operator
  - Flight Refueler
  - Light Aircraft Pilot
  - Reserve Pilot
  - Air Traffic Controller (ATC)

Name of Colour Test	When Administered (Entry/Annual)	Aircrew Category (Pilot/Navigator)	Score (Pass/Fail)	Consequences of Failure (Disqualified/Next Step)
ISHIHARA*	Entry/Annual	SCA/1	No error	Disqualified
ISHIHARA*	Entry/Annual	SCA/2	No error	Beynes Lantern
BEYNES LANTERN	Entry/Annual	SCA/2	No error	Disqualified
NAGEL ANOMALOSCOPE	Only for Pathological Evaluation	Pilot/Navigator	Pass 0.3 - 1.3	
FM-100	Only for Pathological Evaluation	Pilot/Navigator	Score less than 100	
BESANCON	Only for Pathological Evaluation	Pilot/Navigator	Pass	

\* Time of presentations vary: Air Force (0.25 sec); Navy (1 sec); Army (1 sec)



**Table 6.3: Colour vision testing methodology by country (cont'd)**

Country: **GERMANY**

**AIRCREW CATEGORY DESCRIPTION:**

Class 1 – Candidate Pilot; Student Pilot (first part of training)

Class 2 – Trained Pilot, Weapon Systems Officer (WSO), Student Pilot (second part of training)

Class 3 – Navigator; all other personnel not in primary control of aircraft

Name of Colour Test	When Administered (Entry/Annual)	Aircrew Category (Pilot/Navigator)	Score (Pass/Fail)	Consequences of Failure (Disqualified/Next Step)
ISHIHARA/ STILLING-VELHAGEN	Entry/Annual	1,2,3	Pass, no errors	Nagel
NAGEL ANOMALOSCOPE	Entry/Annual	1,2,3	Pass (0.7 - 1.4)	Disqualified (May waiver Class 3 only)

**NOTE:** Also use Rodenstock and Kampeter tests.

Country: **GREECE**

**AIRCREW CATEGORY DESCRIPTION:**

- Student pilot
- Pilot
- Navigator
- Observer

Name of Colour Test	When Administered (Entry/Annual)	Aircrew Category (Pilot/Navigator)	Score (Pass/Fail)	Consequences of Failure (Disqualified/ Next Step)
AO Plates	Entry	Student Pilot	≥ 10/14 correct-pass	Disqualified
	Entry	Observer	≥ 10/14 correct-pass	Disqualified
	Entry/Annual	Pilot	≥ 10/14 correct-pass	Disqualified
	Entry/Annual	Navigator	≥ 10/14 correct-pass	Disqualified

**Table 6.3: Colour vision testing methodology by country (cont'd)**

Country: **ITALY**

AIRCREW CATEGORY DESCRIPTION: (ALL SERVICE BRANCHES)

- Pilot
- Navigator
- Other Aircrew Personnel (Other than Pilot/Navigator)

Name of Colour Test	When Administered (Entry/Annual)	Aircrew Category (Pilot/Navigator)	Score (Pass/Fail)	Consequences of Failure (Disqualified/Next Step)
ISHIHARA	Entry/Annual	Pilot/Navigator	Pass or Fail	Disqualified
NAGEL	Entry/Annual	Other Aircrew Personnel (Other than Pilot/Navigator)	Pass or Fail	Beynes Lantern
BEYNES LANTERN	Entry/Annual	Other Aircrew Personnel (Other than Pilot/Navigator)	Pass or Fail	Disqualified

Country: **JAR**

AIRCREW CATEGORY DESCRIPTION:

- CLASS I – (+3.00 → -5.00)
- CLASS II – (+5.00 → -8.00)

Name of Colour Test	When Administered (Entry/Annual)	Aircrew Category (Pilot/Navigator)	Score (Pass/Fail)	Consequences of Failure (Disqualified/ Next Step)
ISHIHARA	Applicant (Renewal)	I & II	Pass (all plates correct)	Nagel
NAGEL		I & II	Pass (less than 4 scale units)	Beynes/Holmes-Wright/Spectrolux
BEYNES, HOLMES-WRIGHT, SPECTROLUX		I & II	Pass any of these tests (no errors)	“Colour Safe”

**Table 6.3: Colour vision testing methodology by country (cont'd)**

Country: **NETHERLANDS**

**AIRCREW CATEGORY DESCRIPTION:**

- Ia – Candidate Jet-pilot; Student Jet-pilot
- Ib – Jet-pilot
- IIa – Candidate Helicopter; Student Helicopter; Candidate (Board Mechanic); Air Photographer; SAR Tech Candidate
- IIb – Helicopter Pilot; Board Mechanic; SAR Tech
- III – Transport Pilot
- IV – Air Photographer; Board Mechanic; Flight Surgeon; Nurse; Cabin Attendant; Hyperbaric Chamber Personnel

Name of Colour Test	When Administered (Entry/Annual)	Aircrew Category (Pilot/Navigator)	Score (Pass/Fail)	Consequences of Failure (Disqualified/Next Step)
ISHIHARA (16 plate)	Entry/Annual	All	Pass (11/16 correct)	Holmes-Wright
HOLMES-WRIGHT		All	No errors	Slight deuteranomaly permitted

**NOTE:** Board Mechanic = Flight Engineer

Country: **NORWAY**

**AIRCREW CATEGORY DESCRIPTION:**

- A1 – Pilot
- A2 – Pilot with medical restrictions; Student Pilot
- A3 – All other aircrew (Navigator, Flight Engineer, Systems Operator, Loadmaster)

Name of Colour Test	When Administered (Entry/Annual)	Aircrew Category (Pilot/Navigator)	Score (Pass/Fail)	Consequences of Failure (Disqualified/ Next Step)
ISHIHARA (38 plate)	Entry/Requalification	All aircrew	Pass (All correct)	Disqualified

**Table 6.3: Colour vision testing methodology by country (cont'd)**

Country: **PORTUGAL**

AIRCREW CATEGORY DESCRIPTION:

T.G. Applicant (all)

T.C. 1 – Pilot

T.C. 2 – Navigator, Radar Operator

T.C. 3 – Weather Specialists Ground Crew

Name of Colour Test	When Administered (Entry/Annual)	Aircrew Category (Pilot/Navigator)	Score (Pass/Fail)	Consequences of Failure (Disqualified/Next Step)
ISHIHARA	Entry/Annual	All	Pass	Beynes Lantern
BEYNES LANTERN	Entry/Annual	All	Pass	FM-100
FM-100	Entry/Annual	All	Pass	Disqualified

Country: **SPAIN**

AIRCREW COLOUR CATEGORY DESCRIPTION:

GROUP 1 – Pilot (Candidate, Trained)

GROUP 2 – Non-Pilot, Paratrooper (Candidate, Trained)

GROUP 3 – Controller (Candidate, Trained)

Name of Colour Test	When Administered (Entry/Annual)	Aircrew Category (Pilot/Navigator)	Score (Pass/Fail)	Consequences of Failure (Disqualified/Next Step)
ISHIHARA	Entry/Annual	Group 1, 2 & 3	Pass (no errors)	Beynes Lantern
BEYNES LANTERN (Fitness)	Entry/Annual	Group 1, 3	Pass (must pass <u>pure</u> and <u>combined</u> colours)	Disqualified (FM-100 for assessment)
BEYNES LANTERN	Entry/Annual	Group 2	Pass (must pass <u>pure</u> colours)	Disqualified (FM-100 for assessment)

**Table 6.3: Colour vision testing methodology by country (cont'd)**

Country: **TURKEY**

AIRCREW CATEGORY DESCRIPTION:

- Student Pilot
- Navigator
- Pilot
- Weapon System Operator

Name of Colour Test	When Administered (Entry/Annual)	Aircrew Category (Pilot/Navigator)	Score (Pass/Fail)	Consequences of Failure (Disqualified/ Next Step)
ISHIHARA	Entry	All Aircrew	Pass (no errors)	Disqualified
	Annual	All Aircrew	Pass (no errors)	Disqualified (below rank of Major) Waivered (Major and above)

Country: **UK**

AIRCREW COLOUR CATEGORY DESCRIPTION:

- CP1 – Royal Navy Pilot → Colour Normal, Critical Tasks
- CP2 – RAF/Army Pilot, Fighter Control Trades, Navigator, Air Traffic Controller
- All other RAF aircrew → Colour Normal
- CP3 – AF, Cabin Personnel → Colour Defective, Safe
- CP4 – Colour Defective, Unsafe

Name of Colour Test	When Administered (Entry/Annual)	Aircrew Category (Pilot Navigator)	Score (Pass/Fail)	Consequences of Failure (Disqualified/Next Step)
CP1 HOLMES-WRIGHT (Photopic)	Entry	CP1 Royal Navy Pilot	Pass (no errors, low brightness)-(CP1)	Disqualified; Ishihara
CP2 ISHIHARA	Entry	RAF pilot/RAF aircrew/Army Pilot/Fighter Controller/ATC	Pass (no errors)-(CP2)	Holmes-Wright (Scotopic)
CP3 HOLMES-WRIGHT	Entry	CP2 personnel who fail ISHIHARA CP3 Personnel	Pass (high brightness) (ARMY, RAF) or pass (high brightness) in dark @ 15 min - (CP3)	Disqualified; (CP4)

**Table 6.3: Colour vision testing methodology by country (cont'd)**

Country: **US (USAF)**

**AIRCREW CATEGORY DESCRIPTION: ‘FC’ = Flying Class**

- FC I – Student Pilot
- FC IA – Student Navigator
- FC II – Trained Aircrew (Pilot, Navigator or Flight Surgeon) - All Aircraft, No Limitations  
Medically Related Performance Limitation Subsets: IIA – Tanker, Transport, Bomber (Ejection Seat Capable)  
IIB – Tanker, Transport, Bomber (Non-ejection Seat Capable)  
IIC – Specific Aircraft Designated
- FC II Initial – Flight Surgeon Applicant
- FC III – All other crewmembers not in primary control of aircraft - (Air Refuelling Boom Operators, Flight Engineers, Radio Operators, etc.)

**NON AIRCREW:**

- Air Traffic Controller (ATC)

Name of Colour Test	When Administered (Entry/Annual)	Aircrew Category (Pilot/Navigator, etc.)	Score (Pass/Fail)	Consequences of Failure (Disqualified/Next Step)
<b>ENTRY (Applicants)</b>				
• PIP (Red-green)	Entry	I, IA, Initial II, III, ATC	Pass (10 or more correct out of 14)	Disqualified → ACS EVAL
• PIP (Blue-yellow)	Entry	I	Pass	Disqualified → ACS EVAL
<b>RETEST (Trained)*</b>				
• PIP (Red-green)	If acquired deficit suspected	II, III, ATC	Pass (10 or more correct out of 14)	Disqualified → ACS EVAL
<b>ACS EVAL</b>				
• FM-100, D-15 (Sat, Unsat), APT-5, LANTHONY, F2, PIPs II and III, Anomaloscopes	Failed PIP	All Categories	Depends on individual test used	Comprehensive colour vision test battery to assess degree and type of deficiency

**NOTE:** PIP (Pseudo-isochromatic Plates) tests are the only USAF colour vision screening tests used currently. The FALANT has been discontinued and is now only used at Brooks AFB (ACS) as part of the comprehensive colour vision test battery; ACS - Aeromedical Consultation Service, USAF School of Aerospace Medicine, Brooks AFB, TX.  
(\* ) - Retesting of colour vision at periodic intervals to include introduction of blue-yellow testing in trained aircrew has been recommended and is under review.

**Table 6.3: Colour vision testing methodology by country (cont'd)**

Country: **US (US Army)**

**AIRCREW COLOUR CATEGORY DESCRIPTION:**

Class 1 – Warrant Officer Student

Class 2 – Trained Pilot, Student Pilot (after start training), Flight Surgeon

Class 1A – Commissioned Officer Student

Other – Air Traffic Controller (ATC)

Name of Colour Test	When Administered (Entry/Annual)	Aircrew Category (Pilot/Navigator)	Score (Pass/Fail)	Consequences of Failure (Disqualified/Next Step)
PIP (ISHIHARA)	Entry	1, 1A, 2, ATC	Pass ( $\geq 10/14$ correct)	FALANT
FALANT	Entry	1, 1A, 2, ATC	Pass (9/9 or 16/18 correct)	Disqualified

Country: **USN (US NAVY)**

**AIRCREW CATEGORY DESCRIPTION:**

Student Candidates:

SNA – Student Naval Aviator (Pilot)

SNFO – Student Naval Flight Officer (Navigator/System Weapon Officer)

SNFS – Student Naval Flight Surgeon

Trained Pilots:

SG1 – Unlimited Pilot Duties

SG2 – No Shipboard Pilot Duties except Rotary

SG3 – Dual Control Aircraft with other SG1 or SG2 Pilot

Trained Other Aircrew:

NFO – Naval Flight Officer

NFS – Naval Flight Surgeon

Other: Air Traffic Controller (ATC)

Name of Colour Test	When Administered (Entry/Annual)	Aircrew Category (Pilot/Navigator)	Score (Pass/Fail)	Consequences of Failure (Disqualified/Next Step)
PIP	Entry/Annual	All Categories	Pass ( $\geq 12/14$ correct)	FALANT
FALANT	Entry/Annual	All Categories	Pass (9/9 or 16/18)	Disqualified

**This page has been deliberately left blank**



**Page intentionnellement blanche**



## Chapter 7

# Visual Ergonomics of Colour-Coded Cockpit Displays: A Generic Approach

Jan Walraven and J.W.A.M. Alferdinck

The use of colour in information displays requires special skills of the designer, in particular when designing for the harsh light environment encountered in the cockpit. This document deals with the visual ergonomics in question. The following areas of interest are addressed:

- the choice of display technology with the focus on CRT versus LCD.
- the most relevant (ISO) visual standards related to the use of colour on displays.
- guidelines for implementing the standards and additional information on basic issues in display design.
- the problem of contrast reduction due to reflected ambient light.

### 7.1 INTRODUCTION

The displays in the cockpit of an aircraft can be quite complex and have to function in a harsh visual environment that may strongly affect the image quality of the displayed information. Therefore, the visual ergonomics of display design require special attention, in particular when colour displays are involved.

There are two main problems to be considered in the design of a visual display interface of aircrafts, that is, the image quality (contrast, colour palette, graphics, etc.) and the cognitive aspects (structuring, feedback, man-machine dialogue etc.). Here we shall address the aspect of image quality, and thereby focussing on the use of colour. This will be done for the *generic* cockpit display, rather than the various types of avionics that make up today's glass cockpit.

Colour has always been a problematic medium in visual ergonomics. Despite an extensive and diversified literature, including many handbooks, guidelines and standards, the application of all that information to a particular display application should be done with due caution. Much depends on the particular task to be performed and also on the display environment. There is a huge difference between an office (for which most of the display

standards have been developed) and the cockpit of an F-16 fighter aircraft.

Although the specific layout of a display design requires detailed knowledge about its application, there are some general rules that apply to any type of display. Therefore, it is important to get acquainted with existing standards. The search for such standards is not only necessary, for the purpose of good design, but also to warrant that the design will meet future *legislative* requirements for work with visual displays. The latter are already becoming regular practice for office work, and it is to be expected that requirements for other display applications (even the military) will eventually follow suit.

An important consideration in display design is the amount of ambient light that strikes the display. Since this may well be the decisive factor as to whether a display may function at all, it is necessary to be aware of the potential of the current display technology. There still is the question of how to decide on the use of the cathode ray tube (CRT) versus flat panel displays (FPD), and of course, what particular type of FPD.

In the following we shall try to provide some basic information on the issues mentioned above, that is, a short overview of display technology and calibration, a summary of the most relevant ISO standards and some basic facts of colour science that are important for any display designer.

### 7.2 DISPLAY TECHNOLOGY

#### 7.2.1 Selection of Display Options

It is important to know what type of display has to be envisaged when designing a cockpit display. There are many different display technologies available, of which the most relevant ones, that is, those capable of achieving a high-resolution colour display, are:

- Cathode Ray Tube Displays (CRT),
- Plasma Display Panels (PDP),

- Flat CRT,
- Electroluminescent Displays (EL),
- Liquid Crystal Displays (LCD).

Each of these categories can be divided into sub-categories, although many of these are still in a developmental phase, like, for example, the (flat) CRT technologies of vacuum fluorescence, channel multiplier and matrix drive. The literature, which is quite extensive (see reviews by Infante, 1988 and Clark 1990, 1992), indicates that the only realistic choices provided by today's technology are CRT and LCD.

The environment in which cockpit displays have to function poses problems for both CRT and LCD technology. As for the CRT, due to its unsuitability for harsh environments (in particular vibration and magnetic interference), potential safety hazards (high voltage, vacuum tube) and vulnerability to ambient light (washout), this technology would seem to be the least suited for the cockpit. It is true that great technical accomplishments have been made in the avionics industry, where ruggedised CRTs have already been introduced in the cockpit for some time (e.g. Merrifield & Silverstein, 1988), but these are now giving way to LCDs (e.g. Kawahara et al., 1991; Wiedemann & Trujillo, 1993). An important reason for this development is the inherently low diffuse reflectance of the LCD, which makes it much less vulnerable to the washout effect of ambient illumination (Krantz et al., 1992).

Assuming that LCD is the choice of the (near) future, this technology will be discussed in more detail, although it is near impossible to keep up with all the new developments in this field (cf. Tannas, 1994).

### 7.2.2 LCD Technology Options

A survey of the literature on flat panel displays (FPD) leads to the conclusion that the obvious choice for a robust display that can compete with CRT image quality (without the attending weaknesses) is the dot-matrix LCD technology (e.g. Clark, 1992; Tannas, 1994).

The various approaches in LCD dot-matrix technology can be characterised by the different ways in which the polarising effects of the crystals are boosted and/or controlled. The three

major techniques, in chronological order (of development) are:

- the application of the super-birefringent effect (SBE),
- the ferro-electric LCD (FELCD),
- the active matrix LCD (AMLCD).

The two first techniques might be called "passive", due to their relatively slow response time (in the order of 250 ms) compared to that of the active matrix LCD (response time less than 40 ms). The latter is so fast because of the use of an array of "sample-and-hold" semiconductors controlling the individual pixels of the matrix. This array may consist of either two or three-terminal thin-film transistors (TFT), of which the details need not be elaborated here (see Malmberg (1985) for an introduction).

Although the trends in LCD developments are still rather unpredictable, the active-matrix LCD would seem to be the most likely candidate for implementation in aircraft. Apart from technical considerations, the main reason for this choice is the relatively high luminance contrast that this technology may provide. As mentioned above, this is mainly due to its low diffuse reflectance, which has been reported to be in the order of 0.16% (Krantz et al., 1992). This value is quite a bit lower than that of a typical CRT display, where the phosphors may (diffusely) reflect as much as 75% of the incident light. Neutral density and/or polarising filters may be used for decreasing diffuse reflectance (Knowles & Wulfeck, 1972), and thus increase contrast, but at the price of a lower light output. This has the unwanted effect of a large discrepancy between display luminance and the external scene luminance, an issue to be taken up in the discussion of the physiological effects of ambient light.

There are already quite a number of FPDs commercially available, mostly of the TFT LCD type on the market, but this is not the place for a complete survey. It is sufficient to mention that good resolution and graphics (1024×768 XVGA), true colour performance (262,000 simultaneous colours, palettes of up to 17 million colours), good contrast (ratio of 60:1), sufficient luminance (over 500 cd/m<sup>2</sup>) and large viewing angles (well over 90°) are requirements that can be easily met, or even surpassed by current display technology.

## 7.3 VISUAL STANDARDS

### 7.3.1 Convergence on the ISO Standards

A survey of standards, covering ISO, CEN, DIN, BS, ANSI and NEN (the Dutch standard), reveals that although these are largely overlapping, there may be differences in details and issues addressed. Fortunately, international standards are gradually replacing national standards. The general consensus is that the standards developed by the International Organisation for Standardisation (ISO) will become the most likely candidates for future international standards. So, the message is, that the best strategy in conforming to standards is to focus on the ISO standards.

In the following, an overview is given of the most relevant requirements for the application of colour in cockpit displays. It is an excerpt of the design and recommendations, taken from Part 8 of ISO 9241 (ISO, 1997). Only the requirements that specify the visual and physical requirements that are to be strictly followed (in the standard indicated by the word “shall”) are given. Those which are recommended but not necessarily required (in the standard indicated by the word “should”) are excluded from this overview.

These ISO requirements for displayed colours are rather incomplete and also somewhat arbitrary as to the choice of issues that are addressed. The concern about chromostereopsis (a rarely seen perceptual artefact) contrasts with the total lack of information on chromatic induction, one of the more common of the various perceptual artefacts (Walraven, 1985). Still, the requirements and recommendations of ISO 9241-8 provide for sufficient guidance to prevent display designers from making gross mistakes in the use of colour.

### 7.3.2 Military Standards

There are quite a number of military standards that also deal with the use of colour on displays. In a review by Grossman (1992), the following documents are discussed:

- US MIL-STD-1472C – Human Engineering Design Criteria for Military Systems, Equipment, and Facilities (US Department of Defense, 1981).
- US MIL-C-25050A (ASG) – General Requirements for Colors, Aeronautical Lights and Lighting Equipment (US Department of Defense, 1987).

- DGMG Standard for Colour Displays (Canadian National Defence Staff, 1986).
- Draft Standardisation Agreement (STANAG 3940, 3rd Preliminary Draft): Electronic Colour Displays (NATO, 1991).
- Draft Standardisation Agreement (STANAG 4420, Preliminary Draft): Display symbology and Colour for NATO Maritime Units (NATO, 1989).

The military display standards provide similar guidelines as the non-military ones, but, not surprisingly, with more emphasis on topics like ambient light, symbology (mainly for tactical displays) and colour coding (all kinds of maps, warning signals, etc.). A common requirement is that colour coding should follow conventions, such as red for danger and green for safe. Actually there are not too many of such conventions, because historically, colour has mainly been used for aesthetic use, or codes that have little natural meaning, like the coloured bands on a resistor. A notable exception is the use of colour coding in topographical maps. There are various studies in this field that are worth mentioning (e.g. Taylor, 1984, 1985; Spiker et al., 1986), in particular because the electronic map is becoming widely accepted as part of the electronic flight instrument system (EFIS).

A recurrent problem in the application of guidelines and standards to display design is that these are intended for use by human factors specialists rather than display engineers. Often the guidelines are also difficult to understand for designers without the proper background in display design. There clearly is a need for simple answers to the most frequent questions that arise during the first steps in the display design, in particular with respect to the use of photometric and colourimetric units. In the following an attempt is made to do so in a general sense, thereby focussing on the role of the visual system in both the specification and application of display variables.

## 7.4 ELEMENTARY HUMAN FACTORS CONSIDERATIONS

There are complete encyclopaedias dedicated to the human visual system, but those sources of accumulated knowledge are of only limited use for dealing with the visual aspects of display design. The most important message for the display engineer is that the physical representation of a display image bears only a faint resemblance to its

representation on the retina, where it is reduced to a tiny patch of light that is sampled, filtered and processed for transmission to the brain. Everything that affects the retinal image and the underlying neuronal machinery (such as the various systems for gain control) will determine what will actually be seen.

In practice, the problems to be solved in display design require, first of all, knowledge about what the relevant visual dimensions are, and how these have to be manipulated in order to get a certain effect (or get rid of it). For example, what to do when coloured symbology that is legible on one background suddenly disappears, or mysteriously changes in hue when presented on another background? And what are actually the considerations underlying the choice of a particular display luminance and the various ways that can be used for information coding?

A number of such questions, related to visual parameters of the display, and typically encountered in display design, will now be addressed.

### **What is the unit for measuring the brightness on the display?**

*Answer:* Brightness is a subjective descriptor for which there is no standardised unit. However, it is the perceptual correlate of the photometric unit *luminance* (the relationship is approximately logarithmic). The unit of luminance is candela per meter squared ( $\text{cd}/\text{m}^2$ ) and can be measured with a luminance meter. Brightness relates to the luminous aspect of an object (like a bright light) and should not be confused with *lightness*, which relates to surface reflectance (like a light skin). Like reflectance, lightness can be expressed relative to a 100% reflector (perfect white), or in the case of a displayed image, relative to the maximum luminance measured on the display. For more information on these *achromatic* aspects of the visual stimulus see CIE (1988) and Walraven et al. (1990).

### **Does it make a difference what polarity of contrast is used?**

*Answer:* Information may be presented on either a dark or a light background. Conventionally the black-on-white contrast (as in book printing) is called positive contrast, whereas the opposite is called negative contrast. Although optimal legibility of the display can be obtained with both positive and negative contrast, there may be a

preference for one or the other, depending on the viewing conditions and type of display used (Walraven ATC, 1987).

Advantages of negative contrast (black background) are that there is less power consumption (important for battery powered displays) and less noticeable flicker of the display (flicker is more perceptible for large and/or bright displays). However, there are two disadvantages to be considered, that is, specular reflections are more visible (glass may turn into a mirror when the background is completely dark), and the display may appear too dark compared to the brightness of the outside view.

### **What are the units for measuring colour on a display?**

*Answer:* This is a rather involved question. The *physical* definition of colour (as part of light measurement) is simply its spectral power distribution (energy vs wavelength). However, colour as a *percept* is more complicated, requiring a definition in at least three dimensions, i.e. *hue* (red, green, yellow, etc.), *brightness* (a bright yellow or a dark green), and *saturation* (pastel colours are desaturated). Then there is also the *photometric* definition (which relates to light after it has been filtered by the eye media in photopigments), and that is actually the most relevant one. It is based on the fact that the visual system is *trichromatic*, recording light in the photopigments of long-wave (L), middle-wave (M), and short-wave (S) photoreceptors (the cones). It is the L/M/S cone output-ratio that defines the colour of a light. In the standardised photometric system of the Commission Internationale de l'Éclairage (CIE) the *colourimetric* aspect of a light is also expressed in terms of three filtered outputs, the *tristimulus values* X, Y and Z. These filters are not identical to those of the eye, but since they can be expressed as linear combinations of the LMS photopigments they are nevertheless measures of the eye's colour code. This means that when two lights are matched for X, Y and Z, they will be indistinguishable for the eye, even if their spectral distributions are widely different (which is another way of saying that we are all colour blind to a certain degree).

In practice not the absolute values of X, Y and Z are used, but their relative contributions  $x$ ,  $y$  and  $z$  (defined as  $x=X/(X+Y+Z)$ , etc.), the so-called *chromaticity coordinates*. Since  $x + y + z = 1$ , it is sufficient to specify chromaticity with only two of

Table 7.1: Overview of ISO requirements for displayed colours

ISO FDIS 9241-8 Requirements for Displayed Colours		
<i>Topics</i>	<i>Keywords</i>	<i>Specifications</i>
<b>Colourimetrics</b> Colour specification should be in terms of CIE units	<ul style="list-style-type: none"> <li>- luminance</li> <li>- chromaticity</li> <li>- uniform colour space</li> <li>- colour difference</li> </ul>	<ul style="list-style-type: none"> <li>- Y (cd/m<sup>2</sup>)</li> <li>- x, y</li> <li>- u*, v*, L*</li> <li>- <math>\Delta E_{uv}^*</math></li> </ul>
<b>Default colour set</b> Not too many, mutually discr able colours, adapted to the lighting conditions	<ul style="list-style-type: none"> <li>- number of colours</li> <li>- number in case of memory recall or visual search</li> <li>- reflected ambient light</li> </ul>	<ul style="list-style-type: none"> <li>- <math>\leq 11</math></li> <li>- <math>\leq 6</math></li> <li>- <math>Y_R, u'_R, v'_R</math></li> </ul>
<b>Colour display</b> Should be spatially uniform and free from misconvergence (CRT)	<ul style="list-style-type: none"> <li>- uniformity</li> <li>- misconvergence</li> </ul>	<ul style="list-style-type: none"> <li>- <math>\Delta E_{uv}^* \leq 0.03</math></li> <li>- <math>\leq 3.4</math> arcmin</li> </ul>
<b>Coloured imagery</b> Colour coded alpha-numerics and graphics should be large enough for correct colour identification	<ul style="list-style-type: none"> <li>- character height (strings)</li> <li>- single characters and symbols</li> <li>- use of saturated blue imagery</li> </ul>	<ul style="list-style-type: none"> <li>- <math>\geq 20</math> arcmin</li> <li>- <math>\geq 30</math> arcmin</li> <li>- <math>\geq 120</math> arcmin</li> </ul>
<b>Colour difference</b> Discrimination criteria should be in terms of CIE units	<ul style="list-style-type: none"> <li>- minimal discriminability of colour pairs</li> <li>- idem for luminance difference</li> </ul>	<ul style="list-style-type: none"> <li>- <math>E_{uv}^* &gt; 20</math></li> <li>- contrast ratio <math>&gt; 3</math></li> </ul>
<b>Polarity</b> Information can be presented in either negative (dark background) or positive (light background) contrast	<ul style="list-style-type: none"> <li>- dark background</li> <li>- light background</li> <li>- optimal foreground/background colour coding</li> </ul>	<ul style="list-style-type: none"> <li>- avoid deep red (<math>v' &gt; 0.4</math>) and blue (<math>v' &lt; 0.2</math>)</li> <li>- avoid (dim) blue and red</li> <li>- achromatic foreground combined with chromatic background or vice versa</li> </ul>
<b>Depth effects</b> Unwanted depth effects due to chromatic aberration of the eye optics should be avoided	<ul style="list-style-type: none"> <li>- chromostereopsis</li> </ul>	<ul style="list-style-type: none"> <li>- avoid combination of spectral extremes (deep red and blue)</li> </ul>

the three coordinates. The convention is to use only x and y, the coordinates of the well-known CIE 1931 chromaticity diagram.

The x,y coordinates provide a metric for the colour *stimulus*, but not for the *perception* of colours. So, colours that may appear to be fairly far apart in terms of x and y coordinates, may nevertheless be perceived as being fairly similar (like white and yellow, for example). Therefore, the CIE has developed so-called uniform colour spaces, CIELAB and CIELUV (e.g. Hunt). The latter is generally considered to be best suited for self-luminous colours like those generated on an

emissive display (although none of these two colour spaces was designed for that purpose). The CIELUV units are used for specifying colour differences (see Table 7.1), and can be calculated from the X, Y and Z specifications of the stimulus. The procedure for determining colour differences ( $\Delta E$ ) is detailed in the standard ISO 9241-8.

#### **What is the procedure for generating display colours specified in CIE units?**

*Answer:* This amounts to a matrix transformation from XYZ to RGB values, with the RGB video-input voltage typically addressed with 8-bit

precision (DAC values 0–255). Before the transformations can be made the functions relating DAC values to RGB gun luminances, often called gamma functions, have to be determined (to be discussed in the next section).

The best way to select and specify colours for display design is by using a colour editor that operates in both RGB and XYZ space, thereby using the calibration data of the colour monitor in question. Usually the colours used in display applications are specified (if specified at all) in RGB units or derivatives of RGB (like HSL and HSV). However, since visual display units (VDU) may differ with respect to system architecture, electronics and phosphor chromaticities, the same RGB specification may generate quite different colours on different VDUs. In other words, RGB specifications are device-dependent, whereas specifications in CIE units will always specify colour as we see it, irrespective of the device that generates the colour. Therefore, whenever display colours have to meet strict demands as to the reproducibility of a colour coding scheme, as in some display applications where faulty colour coding may be considered as a safety hazard (e.g. Walraven & Alferdinck, 1990), it is a must to specify colour in CIE units.

A point often overlooked in selecting colours for information coding is that the colour gamut that can be generated on a colour monitor is dependent on the required luminance of the colour. It is not possible to generate colours that are both luminous and saturated. This is illustrated in Figure 7.1, which shows the typical colour envelope (in x, y, Y space) of a standard colour CRT.

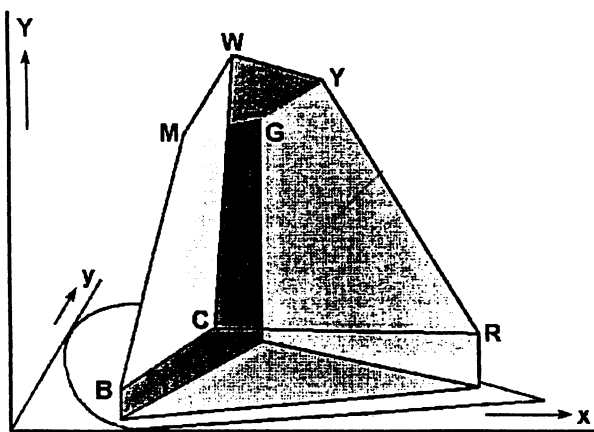

**Figure 7.1: Envelope of colour stimuli that can be generated on a typical colour CRT. Note the reduction in colour space with increasing luminance (Y).**

As is indicated by the conical shape of the CRT's colour space, the available colour gamut becomes smaller when colours have to be generated of relatively high luminance. The first colours that drop out are the saturated reds and blues, so these colours require a certain amount of desaturation (bringing the colours closer to the white point) in order to reach a reasonable luminance level within the colour envelope.

### **What luminance is required for adequate display legibility under ambient illumination?**

*Answer:* This question can only be answered if information is available on the reflective properties of the display, both with respect to diffuse reflectance (mainly from the phosphors) and the specular reflection (from the glass shielding). In addition, much depends on the contrast between the displayed information relative to its background. The contrast depends on differences in luminance, colour and spatial factors (size of symbols, thickness of lines, font type, area fill, etc.). The question will be addressed in detail in a later section.

### **What display luminance is required for viewing the display at night?**

*Answer:* Here too, the exact light level has to be known first. Here it is not the ambient light that poses a problem, but the light emitted by the display. This may affect the state of visual adaptation of the pilot, acting like a glare source. Even more problematic is the effect on night-vision goggles (NVG), a problem known as NVG compatibility of the cockpit instruments. The problem of NVG compatibility falls outside the scope of this chapter (cf. Godfrey, 1991).

### **Are there rules for combining colours in a particular way?**

*Answer:* There are a great number of considerations rather than rules. The most important ones are:

- Vivid colours usually result from narrow selections of the visual spectrum (the reverse, integrating light energy over the whole spectrum, produces white). Consequently, increasing the saturation of a colour will be attended by a reduction of radiant energy, and hence, a reduction of luminance (which is important in the context of high ambient light levels).
- The eye lens is not corrected for chromatic aberration, so colours widely separated in the spectrum (red and blue) or their combinations

(purple) may be slightly out of simultaneous focus.

- Equiluminant colour combination cannot produce crisp contours (because the luminance channel of the visual system is not activated).
- Colours that produce chromatic aberration may also produce unexpected depth differences, an effect called chromostereopsis (cf. Walraven, 1985, for an overview of many other so-called perceptual artefacts).
- It is important to differentiate between foreground and background information. Such a segregation can be achieved by using saturated and desaturated colours for the former and latter, respectively.
- Related information should be coded with related colours (for example, colours differing only in saturation), whereas the opposite holds true for unrelated information (for which complementary colours may be used).
- Some colour combinations are difficult to discriminate for the 8% of the male population (and 0.5% of the females) that suffer from one of the various forms of deficient colour vision. Adequate *luminance* contrast should be used for such combinations.
- There are special metrics (uniform colour spaces) for determining desired differences in colour contrast. A difference,  $\Delta E$ , of 20 to 40 units will generally provide adequate contrast.

### How should a colour palette be selected?

*Answer:* As a first rule one should not try to use more colours than there are necessary for the main functions of colour coding. These are:

- high-lighting;
- contrast improvement between foreground and background colours;
- organisation of the display information and dialogue (colour coding of related information and/or tasks and actions in the man-machine dialogue).

Although this principle may provide some guidance, it still is too general for selecting and combining colours for a specific application. For example, in a study on colour coding of weather maps, a decision had to be made on how to assign seven different colours to seven different precipitation levels (Walraven, 1986). The solution was already constrained in the sense that the seven

colours were already fixed, but that still left 7 (that is, over 5000) different colour combinations! It turned out that in order to achieve optimal discrimination of adjacent precipitation areas, as well as obtaining intuitively transparent colour coding, there was actually a convergence on only one solution.

### What is an appropriate display size for comfortable viewing?

*Answer:* The main determinant of display size is the viewing distance. In order to be legible characters and symbols should subtend about 10–20 arcmin of visual angle. This implies that for an eye-display distance of  $d$  mm, the character matrix should be in the order of at least  $0.006 d$  mm. At a viewing distance  $d=900$  mm, which might be appropriate for cockpit displays, this results in a matrix size of 2.7–5.4 mm. If a large area of the display will be occupied with characters, then the amount of character strings to be displayed simultaneously may turn out to be the major constraint for the display size.

A cockpit display probably will be of the graphical rather than the alpha-numerical type, which means that much depends on the detail of the graphics. To get an idea of display size, one should consider that, due to the limited resolution of a display, the effective visual acuity of the operator will be reduced by about 40% (Walraven, 1984). This means that when the display design, as shown on the drawing, meets the desired legibility criterion, it will have to be magnified by a factor of about 1.7, in order to achieve the same legibility on the electronic display. This only applies, of course, if the viewing conditions for paper and electronic display are comparable (same illumination, contrast, font, etc.).

Since technology and space considerations will probably determine the size of the display to be used, the best strategy is to take those dimensions as a starting point and then adapt the graphics to the available display area, thereby keeping the 1.7 multiplication factor in mind for the presentation of characters and symbols.

### What type of alpha-numerical symbols should be used?

*Answer:* Not all character fonts have the same legibility. A font without any frills, like Helvetica, Arial or MS Sans Serif, will usually provide for the best legibility. Upper case may have a slightly better legibility (for comparable letter size) than

lower case. The major consideration is the size and spacing of the characters; the ISO standards provide the relevant information.

The issues addressed above were primarily selected because these are most relevant for the first steps in display design. However, when it comes to really setting up a display conforming to the ISO standards, there are many other, mostly technical, requirements to be considered. As stated before, many of those should be left to the display manufacturer.

## 7.5 AMBIENT LIGHT

The surface of a display will always reflect a certain percentage of light, partly as specular reflection from the glass shielding, and partly as diffuse reflection from the display surface proper. This reflected light adds to the light emitted by the display and thus causes contrast degradation. The amount of contrast reduction depends on various factors, of which the combined effect can be estimated in the way discussed below.

### 7.5.1 Contrast Reduction by Ambient Light

Contrast can be defined in various ways, but for the present purpose the simplest expression may suffice, i.e. the luminance ratio where  $L_{\max}$  and  $L_{\min}$

$$C = \frac{L_{\max}}{L_{\min}}$$

refer to the higher and the lower luminances defining the information ( $L_i$ ) and background ( $L_b$ ), respectively. This definition has the advantage that it correlates equally well with the subjective strength of negative ( $L_i > L_b$ ) and positive ( $L_i < L_b$ ) contrast.

The luminance of the reflected ambient light ( $L_a$ ) adds to both  $L_{\max}$  and  $L_{\min}$ . In the case of negative contrast (dark background) we have  $L_{\max} = L_i$  and  $L_{\min} = L_b$ , so the contrast will then become

$$C = \frac{(L_i + L_a)}{(L_b + L_a)}$$

The ambient light ( $L_a$ ) consists of a diffuse ( $L_d$ ) and a specular ( $L_s$ ) component, so

$$L_a = L_d + L_s$$

The *diffuse* component,  $L_d$ , is determined by the vertically received illumination at the screen

surface ( $E_v$ ), by the diffuse reflectance ( $R_d$ ) of the display, and by the transmission ( $T$ ) of the glass shielding of the display. A reasonable approximation of the mutual relationship is

$$L_d = R_d T^2 \frac{E_v}{\pi}$$

in which typical values (for CRT) are  $R_d = 0.5$  and  $T = 0.8$ . The vertical illumination,  $E_v$ , is measured in lux; dividing by  $\pi$  is necessary to convert to  $\text{cd/m}^2$ , the dimension of  $L_d$  (which adds to  $L_i$  and  $L_b$ ).

The *specular* reflection component,  $L_s$ , is determined by the reflectance of whatever objects are reflected in the screen (with average reflectance  $R_o$ ) and the specular reflection factor of the glass shielding of the display (with average reflectance  $R_g$ ). It can be computed with

$$L_s = R_o \cdot R_g \cdot \frac{E_v}{\pi}$$

In case of a direct illumination by light source, for example the sun ( $L_{\text{sun}}$ ),  $L_s$  becomes

$$L_s = R_g \cdot L_{\text{sun}}$$

For a worst-case horizontal illuminance of 110,000 lx, and a sun diameter of  $0.5^\circ$ , the corresponding specular reflection from the sun luminance amounts to  $10^8 \text{ cd/m}^2$ .

### 7.5.2 Ambient Light in the Cockpit

In order to evaluate the effect of ambient light on the legibility of a cockpit display, photometric measurements have to be carried out. What one needs to know is the illuminance measured at the location where displays might be installed. This illuminance depends on the luminance outside the aircraft, which is far from constant of course. In the case of an *overcast* sky, there is no direct sunlight and the illuminance is diffuse. The maximum horizontal diffuse illuminance produced by the West-European sky is in the order of 56,000 lx (Hunt, 1979). The maximum illuminance produced by *direct sunlight* can be as high as 110,000 lx (Hunt, 1979), which would imply, taking into account the transmission of the window (in the order of 70%), that the display illuminance can be as high as  $0.7 \times 110,000 = 77,000$  lx. This should be compared to normal office illumination, which is typically less than one percent of that value.



### 7.5.3 Reflected Light Computations

Knowing the illumination at the display surface one can compute the attending reduction in contrast of the displayed information. As an example we consider the different effects for two display technologies, CRT and LCD, thereby assuming that 5% of the ambient light finds its way to the display surface.

The calculations are based on a number of assumptions regarding the display variables. The diffuse reflection factor ( $R_p$ ) of the CRT display was set at 0.10, a value intermediate between the maximum and minimum found in practice. For the LCD, a diffuse reflection factor of 0.0015 is assumed, consistent with current technology (e.g. Krantz et al., 1992). The transmission of the front glass ( $T$ ) for both technologies was set to 0.8. The specular reflection ( $R_s$ ) is for both display technologies the same, that is, in the order of 0.04. For a special treated front glass the reflection can be lowered to 0.005 (by using  $1/4 \lambda$  coating). The illuminance of the object in the cabin is assumed to be equal to the display illuminance. The reflection of the interior of the cockpit ( $R_o$ ) is assumed to be 0.5 (a light grey).

The example shown in Table 7.2 indicates that the LCD provides for much better contrast than the CRT, due to its very low diffuse reflection. It is also clear that an anti-reflection coating is very effective (see the value of 15.7 for LCD).

Considering that we assumed an initial display contrast of  $C=50$ , it is clear that ambient light causes a considerable contrast reduction, down to values between 1.06 and 15.7. If there is no way of reducing the incident ambient light, contrast can only be increased by increasing the luminance of the display.

### 7.5.4 Colour Washout

Adding white light to a coloured light reduces the purity of the colour (deep blue may turn into pale blue), an effect called desaturation. Ambient (white) light also adds to the coloured light emitted by a display, so when computing a required colour difference ( $\Delta E$ ) one should include the (additive) effect of the reflected ambient light into the calculations.

The colourimetries involved in computing the colour shift due to the additive effect of ambient light are discussed in ISO/FDIS 9421-8. The procedure involves the computation of the X, Y, and Z CIE units of both the displayed colour and the ambient light component. The X, Y, and Z values are added and the resulting corrected values imputed in the equations for computing the colour coordinates in the CIELUV system.

### 7.5.5 Physiological Effects of Ambient Light

In addition to reducing the contrast of the display image – a *physical* effect – the ambient light also affects the sensitivity control (adaptation) of the eye – a *physiological* effect. Visual sensitivity control is not instantaneous, so whenever the eye is confronted with a sudden change in the prevailing luminance, it takes some time to re-adjust sensitivity. This is particularly noticeable when the luminance change is from light to dark. This is what happens in the cockpit when the pilot shifts his gaze from the outside view to the relatively dark instrument panel inside the cabin.

Results from a study by Boynton et al. (1969) indicate that adaptation times begin to add significantly to reaction times when there is about a hundred-fold change in luminance, when shifting

**Table 7.2: Display contrast of CRT and LCD displays for worst-case lighting conditions, for the case of 5% incident light on the display surface. 56,000 lx=overcast sky, 110,000 lx=direct sunlight, treated=anti-reflection coating, not-treated=no anti-reflection coating.**

Illuminance (Lx)		Display Technology	Contrast	
Outside Cockpit	Inside Cockpit		Not-treated	Treated
56,000	4,260	CRT	1.85	2.06
56,000	4,260	LCD	4.22	15.7
110,000	77,000	CRT	1.05	1.06
110,000	77,000	LCD	1.19	2.13

from adaptation to target luminance. More recently, Krantz et al. (1992) tested the effect of very high ambient illumination levels on the visual performance of an LCD display in a cockpit mock-up. They showed that a display luminance of 180 cd/m<sup>2</sup> yielded asymptotic visual performance (in a speeded acuity test). The light conditions used in that experiment were such that the adaptation/display luminance imbalance was about a factor 140, which, considering the difference in experimental conditions, is in reasonable agreement with the results of the Boynton et al. (1969) study. For viewing the display at night the lighting conditions are reversed. Now it will be the display that may be too bright compared to the ambient illumination. Dimming the display luminance might seem the logical solution for this problem, but it may be necessary to also change the polarity of the display.

### 7.5.6 Polarity of Luminance Contrast

In conditions with a high level of ambient light, the display should be as bright as possible. The first step to achieve that goal is to avoid intrinsically dark colours for large areas. This implies that the contrast between information and background has to be shown in *negative* polarity. The advantages of negative polarity are two-fold, (a) a better luminance balance between display and outside view, and (b) less visibility of specular reflections.

The possible disadvantages of negative polarity, more power consumption and more noticeable flicker do not apply when using an LCD display (when not battery powered), but even for a CRT such disadvantages would be outweighed by the benefit of a more “light resistant” display.

The advantages of negative polarity do not apply for displays that are used at night. That condition actually would benefit from positive polarity, even if it will usually necessitate a different use of colour and luminance contrast (cf. Walraven & Alferdinck, 1988). It is important, however, not to use different colour coding for the night and day display, except for changes in *luminance polarity*, and even then one should be aware that the perception of colours may become quite different when seen in a different polarity. For example, orange on a black background may turn into brown when the dark background is replaced by a white background.

## 7.6 REFERENCES

1. Boynton, R.M., Rinalducci, E.J. and Sternheim, C. (1969), Visibility losses produced by transient adaptational changes in the range from 0.4 to 4000 footlamberts, *Illuminating Engineering*, 64, pp 217-227.
2. Canadian National Defence Staff (1986), *DGMG Standard for Colour Displays (OP1: DMES 5)*, Ottawa: Canadian National Defence Staff.
3. CIE (1988), *Spectral luminous efficiency based upon brightness matching for monochromatic point sources 2° and 10° fields* (CIE Publication 75), Vienna: Central Bureau of the CIE.
4. Clark, M.G. (1990), Liquid crystal devices. In R.A. Meyers (Ed.), *Encyclopedia of physical science and technology 1990 yearbook*, pp 401-416, San Diego, CA: Academic Press.
5. Clark, M.G. (1992), Flat-panel displays. In H. Widdell and D.L. Post (Eds.), *Color in electronic displays*, pp 257-275, New York: Plenum Press.
6. Godfrey, G.W. (1991), *Principles of display illumination techniques for aerospace vehicle crew stations*. Aerospace Lighting Institute, Tampa, Florida.
7. Grossman, J.D. (1992), Color conventions and application standards. In H. Widdell and D.L. Post (Eds.), *Color in electronic displays*, pp 209-217, New York: Plenum Press.
8. Hunt, D.R.G. (1979), *Availability of daylight*, Watford, UK: Department of Environment.
9. Infante, C. (1988), Advances in CRT display. *Proceedings of the 1988 International Display Research Conference*, pp 9-12, New York: Institute of Electrical and Electronic Engineers Inc.
10. ISO (1997), ISO/FDIS 9241-8.2, *Ergonomic requirements for office work with visual display units (VDTs) – Part 8: Requirements for displayed colors*, Geneva: International Organisation for Standardisation.

11. Kawahara, H., Wakairo, K. and Watanabe, A. (1991), *Flight simulator evaluation of D-size Liquid Crystal Flat Panel Displays; technical report* (Report NAL/TR-1136), Tokyo: National Aerospace Laboratory.
12. Knowles, W.B. and Wulfeck, J.W. (1972), Visual performance with high-contrast cathode ray tubes at high levels of ambient illumination, *Human Factors*, 14, pp 521-532.
13. Krantz, J.H., Silverstein, L.D. and Yei-Yu Yeh (1992), Visibility of transmissive Liquid Crystal Displays under dynamic light conditions, *Human Factors*, 34, pp 615-632.
14. Malmberg, P.R. (1985), Active-Matrix addressing technology. Society for Information Display, *1985 Seminar Lecture Notes*, (Vol. 1), pp 3.21-3.28, New York: Pallisades Institute for Research Services Inc.
15. NATO (1991), *Electronic Colour Displays. Draft Standardisation Agreement (STANAG 3940, 3rd Preliminary Draft)*, Brussels: NATO Military Organisation for Standardisation.
16. NATO (1989), *Display symbology and Color for NATO Maritime Units. Draft Standardisation Agreement (STANAG 4420, Preliminary Draft)*, Brussels: NATO Military Organisation for Standardisation.
17. Spiker, V.A., Rogers, S.P. and Cicinelli, J. (1986), Selecting color codes for a computer generated topographic map based on perception experiments and functional requirements, *Ergonomics*, 29, pp 1313-1328.
18. Tannas, E.T. (1994), Evolution of flat-panel displays, *Proceedings of the Institute of Electrical and Electronics Engineers (IEEE)* Vol. 82, pp 499-509.
19. Taylor, R.M. (1984), Colour coding in information displays: heuristic, evidence and expertise from cartography, In C.P. Gibson (Ed.), *Proceedings of NATO workshop on "Colour coded vs monochrome displays"*, pp 35.1-35.46, Farnborough: Royal Aircraft Establishment.
20. Taylor, R.M. (1985), Color design in aviation cartography. *Displays (October)*, pp 187-201.
21. US Department of Defense (1981), *Human Engineering Design Criteria for Military Systems, Equipment, and Facilities* (US MIL-STD-1472C), Washington, DC: US Department of Defense.
22. US Department of Defense (1987), *General Requirements for Colors, Aeronautical Lights and Lighting Equipment* (US MIL-C-25050A ASG), Washington, DC: US Department of Defense.
23. Walraven, J. (1984), A moving-map display for the F-16; the legibility aspect. *Memo IZF 1984-M2* (In Dutch), Soesterberg, The Netherlands: TNO Institute for Perception.
24. Walraven, J. (1985), The colors are not on the display; a survey of non-veridical perceptions that may turn up on a color display, *Displays*, 6, pp 35-42.
25. Walraven, J. (1987), *Color coding for ATC displays* (EEC Report No. 212), Brussels: Euro Control.
26. Walraven, J. (1992), Color basics for the display designer. In H. Widdell and D.L. Post (Eds.), *Color in electronic displays*, pp 3-39, New York: Plenum Press.
27. Walraven, J. and Alferdinck, J.W.A.M. (1990), *Color specifications for the electronic chart display and information system (ECDIS)* (Report IZF 1990 A-19), Soesterberg, The Netherlands: TNO Institute for Perception.
28. Walraven, J., Enroth-Cugel, C.H., Hood, D.C., MacLeod, D.I.A. and Schnapf, J.L. (1990), The control of visual sensitivity: receptor and post-receptor processes, In L. Spillmann and J.S. Werner (Eds.), *Visual perception: the neurological foundations*, pp 53-101, San Diego, CA: Academic Press.
29. Wiedemann, J. and Trujillo, E.J. (1993), Primary Flight Display conversion: 747-400 CRTs to LCDs, *SID 93 Digest*, pp 514-517, New York: Pallisades Institute for Research Services Inc.

**This page has been deliberately left blank**



**Page intentionnellement blanche**

## Chapter 8

### Display Technology: A Generic Approach

Alain Léger

#### 8.1 DISPLAY TECHNOLOGY CLASSIFICATION OF DISPLAYS

Technological analysis begins with a classification of the various existing display devices.

Several classification criteria can be used:

- the screen observation mode,
- the type of electro-optical effect used,
- the modulation environment,
- the modulation device addressing method,
- the colour reproduction mode.

The two main observation modes to be considered are:

- direct vision display,
- optical projection display.

The two types of electro-optical effect used to generate the image are:

- emissive effects (direct modulation of the light source),
- non-emissive effects (remote light source).

Among the emissive effects we can quote:

- cathodoluminescence (for example cathode ray tube),
- electroluminescence (for example diode, monochrome plasma),
- photoluminescence (for example colour plasma).

Among the non-emissive effects, we can quote the diffraction of light, diffusion of light and induced birefringence.

The modulation environment may be:

- a gas (for example plasma),
- a liquid (for example liquid crystal),
- a solid (for example the phosphor powder in a cathode ray tube).

The main addressing methods are:

- electrical addressing (for example matrix),
- electron beam addressing (for example cathode ray tube),
- photo-electrical addressing (optical using a photo-conductive material).

Colour production is:

- either intrinsic to the material (for example phosphors in a cathode ray tube or a colour plasma screen),
- or extrinsic to the material and achieved by filtering of the radiation (e.g. colour liquid crystal screen).

#### 8.2 ANALYSIS OF THE DIFFERENT CLASSES

##### 8.2.1 Plasma Screens

A glow discharge in the ultraviolet band in a gas excites a red green or blue photoluminescent powder.

Addressing is directly multiplexed with high control voltages of the order of 150 V.

The grey levels are obtained sequentially.

There are two families of screens: the AC plasma display panel (AC-PDP), and the DC plasma display panel (DC-PDP).

Large size screens can be produced, however resolution is limited by video cross-talk (inter-pixel coupling) and by the size of the glow discharge.

Contrast is fairly sensitive to ambient illumination, as unlike monochrome plasma panels in which the emissive material is a gas, the emissive medium is a solid diffuser (phosphor).

The main limitations concern the resolution level (minimum inter-pixel step 0.36 mm) and the luminance level required to provide a minimum level of contrast in high ambient illumination.

## 8.2.2 Electro-Luminescent Colour Screens

The light is emitted by a powder or a thin film subjected to an AC or DC electrical field. The colour is obtained either by choice of a material which emits in one of the primary colours, or by filtering of white radiation.

Addressing is directly multiplexed type with high control voltages, requiring voltages of the order of 200 Volts.

Modulation of the control voltage enables direct modulation of luminance.

This technology is rugged, simple and “fully solid”. Thickness is low.

The best resolution is obtained with a pitch size of 0.3 mm for a diagonal of 10” (thin film alternative screen by Planar System). Efficiency varies between 0.1 and 0.8 lm/W depending on the colour.

The main limitations concern luminance and in particular blue luminance (1 cd/m<sup>2</sup> in image region), resolution (due to the resistivity of the electrodes) and size (electrical capacity of the pixel).

### 8.2.3 Colour Cathodoluminescent Matrix Screens

Light is emitted by cathodoluminescence (luminescent and more precisely fluorescence, under the effect of electronic bombardment), and low acceleration voltage (200V).

VFDs (Vacuum Fluorescent Devices) use heated cathodes and only exist in polychromatic versions.

Fluorescent micro-dot screens (EFM) or FED (Field Effect Display) extract electrons from cold cathodes by field effect. The thinness of the screen removes the need for a focusing voltage and enables use of low control voltages (30kV).

Addressing is multiplexed type. Modulation of luminance is continuous. Luminous efficiency of the phosphors varies between 0.6 and 4.5 lm/W.

Colour is produced both sequentially and spatially: the screen is split into red, green and blue monochrome sub-pixels interconnected by three different anodes; each cathode is assigned to one of three monochrome sub-pixels, which are excited in turn by the switching of the anode voltages.

This technology, which is still immature industrially, is for the moment unsuitable for the whole range of performances. One of the main limitations remains the high sensitivity of the contrast to ambient illumination (opaque solid).

## 8.2.4 Colour Cathode Ray Tubes

The light is emitted by cathodoluminescence at a high acceleration voltage (30kV).

Addressing this either matrix type, or more generally, by spatially continuous electromagnetic deflection of the electron beam.

Colour synthesis is either temporal (“Tectronics” chromatic shutter placed in front of a white phosphor) or, more generally, spatial, using monochrome phosphors addressed individually.

Selection of the basic colour of the phosphor (red, green or blue) is achieved either sequentially by the electronic switching of a single gun (beam index tube), or more generally, by spatial filtering of the electron beam supplied by each of the three guns (either “Shadow Mask” or “Trinitron”).

Luminance modulation is continuous with a broad dynamic range.

The luminous efficiency of the phosphors is high: between eight and 60 lm/W, although these values must be strongly weighted by transmission of the mask (<20% at high luminance).

Current screen sizes are between 14” and 40”.

Spatially continuous addressing (deflector controlled by an analogue voltage) ensures very good image quality.

Resolution depends on luminance (through variation of size with beam current) and on the pitch of the mask (depending on the pitch of the screen).

The resolution level gives a definition which can attain two thousand dots, for a diagonal of 18” and a mask pitch of 0.15 mm.

Life cycle is long (up to 15,000 hours).

The fundamental limitation is due to the composition of the screen; it is composed of an opaque phosphor powder and which has the

disadvantage of being sensitive to contrast in ambient illumination. There are other limitations, in particular in so far as concerns overall dimensions and weight for a given screen area.

### 8.2.5 Central Colour Vision Matrix LCDs

On these non-emissive, matrix screens, the image is generated by electrically controlling the optical transmission of each pixel. A separate source of white light is necessary, and it is normally polarised.

Colour is achieved by means of absorbent optical filters, the sub-pixels normally being rectangular and of format 1/3 (width/height).

Backlighting is provided by an assembly of fluorescent tubes, which intrinsically provide good luminous efficiency. Unfortunately, this is largely compensated for by the performance of the rest of the lighting system, whose function consists of recovering all the omnidirectional luminous flux produced by several separate tubes and only directing this flux to the screen, while ensuring correct homogeneity.

### 8.2.6 General Presentation of LCD Screens (Central vision or not)

#### Liquid Crystal Technologies

The main types of liquid crystal used at the present time are:

- twisted nematic liquid crystal (TN),
- super twisted nematic liquid crystal (STN),
- ferro-electric liquid crystal (FLC),
- polymer dispersed liquid crystal (PDLC),
- electrically controlled birefringence liquid crystal (ECB).

The transparent liquid crystal is contained between two glass surfaces fitted with transparent electrodes between which flows a control voltage of a few volts amplitude.

#### Addressing LCD Screens

As a general rule, screen addressing is, on the one hand electrical, and on the other, matrix type (pixel sampling). Other types of sampling exist, and, except for pixel sampling, they are mainly

encountered when using valves to project large images:

- thermal addressing,
- photo-electric addressing,
- active plasma matrix addressing.

#### Active Matrix Technology

Unlike passive matrices, (or directly multiplexed matrices), for which the pixel signal electrode is common to all pixels in the same column, electrical isolation between pixels in the same column is provided by a threshold element, activated by a switch and associated with each pixel.

This active element, deposited in thin films, either has 2 terminations (diode), or 3 terminations (transistor).

Diode technologies have the advantage of simplicity of production (in particular, no crossing of electrodes) and symmetrical electrical behaviour.

The two currently available thin film diode matrix technologies (TFD), are:

- D<sup>2</sup>R technology (Diode-Diode-Reset),
- MIM technology (Metal Insulator Metal).

#### Comparison of Liquid Crystal Technologies

Active matrix TN technology is currently the most effective of these technologies, in particular in terms of contrast and response time. Modulation of the control voltage enables continuous variation of optical transmission.

STN technology, designed for direct multiplexing, provides optimum cost and optical transmission, (possibility of subtractive colour synthesis); it does not in principle supply grey levels, and its response time is slow. Its low angle of view and high intrinsic colouring can be compensated for by the addition of either a birefringent optical film, or a second, reversed twisted cell, so as to produce a DSTN structure (double STN).

FLC technology provides a very wide angle of view and a very short response time, and therefore a short addressing time (70µs). By its very nature, bistability does not produce intermediate levels; addressing time is still not short enough to show sequential grey levels on a high definition screen.

PDL technology has good optical transmission as, unlike other technologies which operate in polarised light, it directly modulates natural light. Unfortunately, contrast is too low with central vision so that it can only be used for projection for the moment.

The problem of hysteresis defect inherent in this technology is being solved; the value of the control voltage, originally quite high, is at present almost equivalent to that of the twisted nematic.

### Performances (central vision)

The well-known advantages of LCD screens for central vision are, lightweight (<1.7 kg for 15" diagonal), compactness (about 20 mm), low levels of control voltage and high levels of insensitivity to ambient illumination.

This insensitivity to radiation is due to the fact that the liquid crystal valve is a light modulator; it transmits or absorbs luminous radiation but does not reflect it.

The technology which provides the best image quality at the moment is active twisted nematic liquid crystal (TN-LCD).

The dominant active matrix technology is amorphous silicon transistor.

The number of grey levels varies at present between 16 and 256; it is no longer limited, in the sense that fully analogue peripheral column circuits (i.e. without grey level quantification) are beginning to appear.

Definition levels currently achieved are of the order of 1280 X 1024.

The directivity of the electro-optical effect means that constant contrast cannot be maintained in all directions of observation. Various techniques for increasing the angle of view are under development; among these are compensation by birefringent film or division into domains (splitting up of the pixel into several directivity domains which are complementary although activated by the same electrical signal).

The fact that colour is achieved by the addition of absorbent filters, considerably reduces overall luminous efficiency, and thus white light transmission is typically of the order of 4% (including the back polariser and the front analyser).

This low transmission value explains the large number of fluorescent backlighting tubes required to produce the desired light level; as the density of tubes increases, so tile collection efficiency is reduced.

The luminous efficiency of present day light boxes is of the order of 30 lm/W, which produces an overall display efficiency of 1.2 lm/W.

## 8.3 TRC OVERHEAD PROJECTORS

The three monochrome images making up the colour image are presented separately on three monochrome tubes, then projected onto a variable luminance screen which accepts either back projection or front projection.

The three images are generally combined directly on the projection screen using three offset lenses, or sometimes a single lens preceded by a mixing device.

The variable luminance projection screen is directive, enabling increase of null emergence light to the detriment of other directions.

Recent work mainly centres on lens/tube coupling (coupling fluid between the tube and the first lens element, interferential filter directing the light flow in the perpendicular direction) and on the quality of the light gun and the electronic focusing optics (size of the spot).

The absence of a mask prevents degradation of luminous efficiency, resolution and maximum power.

The trade-off between definition and size produces high luminance tubes with a diagonal of between 5 and 9 inches, with a projected image diagonal of between 40 and 200 inches.

Vertical definition is up to 1152 lines.

The interdependence between luminance and resolution, previously mentioned in connection with central vision cathode ray tubes, is also present on projection. In addition, the limitation on total power of the tubes results in a greater limitation on large image region light levels than on those of small image regions (peak luminance); as a result, light levels are often given for one tenth of the total surface area.



## 8.4 LCD COLOUR PROJECTORS AND OVERHEAD PROJECTORS

### 8.4.1 Light Sources

The only sources of luminous power capable of supplying high power, with good luminous efficiency and small geometrical coverage, are sources of white light, using either tungstenhalogen incandescence technology or short arc discharge type, using xenon or metal halogenide technology.

The latter technology is preferred these days, and for reasons of spectral shape, luminous efficiency and durability, in spite of its large geometrical coverage compared with xenon technology.

Having an illuminating laser beam for each colour channel would provide undeniable benefits. Unfortunately, laser sources cannot at present be envisaged and the situation will not change until compact blue light sources become available (solid material).

### 8.4.2 Colour Synthesis

The various combination modes are as follows:

- "subtractive" synthesis,
- additive temporal synthesis,
- additive spatial synthesis by juxtaposition,
- additive spatial synthesis by superimposition.

Colour synthesis in the subtractive mode induces high power losses, as transmissions increase ( $<1$ ), instead of averaging out, as is the case for additive synthesis.

In practice, additive synthesis is the most commonly used mode, either spatially (in most cases) or temporally.

Additive temporal synthesis is achieved by sequential decomposition of white lamp radiation into three monochrome beams.

Other factors which influence the final quality of the image should be taken into account, in particular the screen gain, (linked to its directivity) and the homogeneity of luminance.

The number of grey levels is no longer limited, to the extent to which fully analogue column drivers

are becoming increasingly common in even more significant proportions than for central vision LCDs.

Overhead projectors, which contain reflecting mirrors and screen mirrors, are considerably larger and heavier than direct projectors. These differences increase as the image size increases.

Maximum definition is 1440 X 1024 using nematic twist technology and 720 X 480 with the PDLC technology.

## 8.5 MISCELLANEOUS PROJECTION SYSTEMS

The systems can be classified according to the type of modulation environment:

- solid,
- liquid,
- liquid crystal.

### 8.5.1 Micro-Mirror Matrix (DMD: Digital Micro-Mirror Device)

This electromechanical optical valve produced by Texas Instruments works by reflection. Composed of an array of electrically controlled mirrors, it is designed as a monolithic circuit on an electronic addressing circuit composed of RAM CMOS memory cells.

These 16 $\mu$ m wide mirrors, set in steps of 17 $\mu$ m, have two bistable orientations with respect to the general plane of the matrix: +10° and -10°.

They are suspended from torsion bars on fixed supports and activated by electrostatic attraction.

The short response time, of the order of 10 $\mu$ s, enables display of sequential shades of grey (256 with a specific sequence at 8 bits).

### 8.5.2 Deflected Laser Beam System

The three axis deflection of three laser beams, modulated red green and blue can be achieved using a number of different devices: a galvanometric deflector, a piezo-electric deflector, or an acousto-optical deflector.

One important advantage of the laser beam is its high luminance, which enables high image luminance levels while retaining good definition.

However, as indicated previously, laser sources are not a feasible proposition at the moment, and the situation will not change until such time as new, and sufficiently powerful, compact blue light sources become available (solid material).

This technology is undergoing constant development and its high interest justifies re-examination of its possible use in the future.

## Chapter 9

### Optical and Electro-optical Devices: Consequences for Colour Vision

J. Terry Yates and Marie-France Heikens

The point has been made elsewhere in this document, that the visual system is complex and involves photochemical events, electro-physiological transformations and interactions that result in a psychological experience. Many variables influence the end result including at least:

- stimulus brightness,
- saturation,
- the influence of adjacent colours,
- stimulus size and duration,
- fatigue and afterimages (one of several cases of adaptation),
- the health of the visual system (age, disease, and drug usage).

When the system is challenged by inserting an appliance in front of the eye (filter, head-up display, head-down display, or even a clear protective visor), the question arises as to the magnitude of the influence of such a device. In a general sense, all of these devices are some form of optical filter. There is a tenant in optical engineering that says such filters may not enhance an image, they may only remove image information. Colour vision is dynamic, adaptive, non-linear and complex and so the question to be considered is: "Are the engineers correct, or does the nervous system have some special attributes to bring to bear?" A few practical examples will serve to introduce the problem.

In 1968, the US Air Force became concerned about the use of waveband filters that were popular at the time, namely the Kalichrome C (yellow) filter and the Cosmetan (brown) filter (Kislin et al., 1968). The approach the scientists of the time used to understand is characteristic of the way the problem continues to be evaluated and is presented to illustrate the sorts of research that have been done. First, there was a laboratory study that evaluated the spectrophotometric characteristics of tree leaves of various hues. With this data in hand, changes in

luminosity and chromaticity of these targets induced by coloured filters were calculated. The conclusion reached from that modelling effort was that the filters offered no calculable advantage in detecting tree leaves.

Second, another laboratory investigation was undertaken involving nine aerial photographs. One of the photographs showed defoliated vegetation and the rest were normal. The task was to pick out the defoliated view with and without the test filters.

The result was a bit inconclusive. Brown on green targets were easier to detect with the yellow lenses. However, the authors were forced to conclude that the result was explainable on the basis of achromatic contrast changes in the luminance system and was not clearly colour vision related.

The final effort was a field study with F-4 pilots flying at high speed and low altitude while they attempted to identify "real world" targets with and without the filters. The test targets included: crossroads, a fire tower, a railroad crossing, a dirt road, a lake and a stand of trees. The result is a familiar one; there were no differences in performance when the yellow lenses were used.

The final evaluation included a procedure that is still in use; an interview of the participants. Nine pilots felt that colour perception was improved by the filters. Twelve pilots felt there was no change involved. Another nine felt that the filters interfered with colour vision. There were favourable comments and unfavourable ones.

Favourable comments included statements such as:

"When there is a definite contrast between target and surrounding area, the yellow lens is an aid."

"The yellow lenses improve horizon visibility under hazy conditions."

"Significant help in hazy, cloudy day!"

"Lenses are great."

Unfavourable comments were:

“Yellow lenses reduce, almost eliminate contrast.”

“Had difficulty distinguishing between trees and small lakes. With time I feel I could **learn** (emphasis added) to use lenses to my advantage.”

“Objects appear brighter but colour differences are harder to see and appear to merge.”

“Difficulty was experienced in seeing camouflaged aircraft from above when a known position was being observed. Shadow was seen but bird was invisible.”

The conclusions were that subjective evaluation was not born out by the facts. The authors conclude:

“The use of yellow lenses is no panacea for all flyers engaged in counterinsurgency warfare. While the ability to discriminate between certain colours in the misty early morning increased, the ability to discriminate between other colours is decreased. It would be necessary to know the colour and brightness of the target before the mission in order to recommend yellow lenses - not a very practical requirement.”

In a rather comprehensive study (Hovis et al. 1989) evaluated contrast sensitivity (a rather complete characteriser of spatial visual resolution), stereopsis (Howard-Dolman), colour (FM-100) and the steady-state checkerboard Visual Evoked Potential (VEP) when subjects wore a “blue-blocker” (yellow lenses), a neutral density filter matched for luminance or no filter. The results were striking.

Contrast sensitivity for the “blue-blocker” and neutral density conditions when compared to the no filter condition showed increased low frequency sensitivity, normal middle frequencies and decreased high frequencies. Stereopsis was not impaired. The VEP showed longer implicit times for yellow lenses when compared with the neutral density condition indicating longer processing time for the pathway from the eye to the brain.

The FM-100 showed a tritan defect for the “blue-blocker” condition or a loss in blue-yellow sensitivity. The neutral density condition caused

more errors but the results were within normal limits. This effect is known and the test instructions warn about the use of the wrong intensity lighting conditions. Colour defectives (dichromats) gave chaotic responses suggesting absence of colour discrimination. That is, whatever remaining colour capability the dichromats had was erased by the introduction of a filter.

What, then, are selective waveband filters doing? First, they are designed to filter out specific wavelengths and they do so. The results are induced colour vision deficits with a reduction in overall scene luminance. They appear to exaggerate some colours at the expense of others. They do not seem to enhance high contrast acuity targets. They may produce a situation where relearning of the actual colour from its filtered appearance is required resulting in slowed responses. They have complex influences on colour defectives. They impact display and symbology appearance in the near field and interfere with object identification in the far field.

A troubling aspect of the laboratory data is that it is in conflict with what is reported by some pilots and other aircrew. They feel that they see better, things look brighter, there is more contrast, haze is reduced and so on. Many studies involve questionnaires and interviews and one must wonder if the laboratory scientists are asking the right questions.

## 9.1 LASER EYE PROTECTION

The situation described above is magnified when the additional problem of adequate laser eye protection is addressed. The laser has permeated the military and civilian world for a variety of reasons. A home CD player contains a laser. In the military, the battlefield, training areas, industrial sites and research laboratories often contain lasers. Exposure to a laser may have no visual effect at one end of the spectrum, and at the other end cause permanent, irreversible eye damage. The effects of ocular exposure have been described as being separable into four general categories: glare, flashblindness, thermal lesions and haemorrhage lesions. Glare and flashblindness are temporary effects whereas thermal lesions and haemorrhagic events are not. (Thomas, 1994) Therefore the challenge for vision scientists is to find a cost effective, pilot acceptable, laser protective device

**Table 9.1: Aircrew Laser Eye Protection (ALEP) effects**

<b>OUT-OF-COCKPIT VISION</b>	<b>IN-COCKPIT VISION</b>
Exterior aircraft lighting visibility	Warning, caution and advisory light visibility
Blending of terrain colours and features	Head-up display and monochrome head-down display visibility
Reduced depth perception	Maverick missile display visibility and utility
Reduction in tally-ho ranges (subjectively measured)	Time required to adjust when transitioning from out-of-cockpit viewing
Inadequate sun protection	

that serves to neutralise the challenge from battlefield lasers. Spin-offs to laser laboratories and commercial sites are inevitable.

In a recent document, the staff of the Laser Bioeffects Division at Brooks Air Force Base, have compiled a list of recommendations for flight surgeons and other eye-care personnel when dealing with aircrew laser eye protection (ALEP). Briefly, they recommend:

“All filters that selectively absorb visible light, including ALEP, have the potential of altering vision. Prior to flying, the ALEP device must be authorised as safe for use to fly.” (Cartledge, et al., 1995) The way in which this requirement is satisfied will vary throughout NATO. However, the recommendation continues with the suggestion that: “Evaluations of the visual effects of ALEP devices should be conducted using all aircraft for which their use is intended. This requirement is due to different aircraft having different avionics systems and exterior lighting as well as their aircrew having different visual demands associated with their missions. ALEP devices do not need to be tested on each intended aircraft if two or more of the aircraft types have similar lighting and mission characteristics. In these instances, the test results from one aircraft can easily be generalised to the other(s). The necessity of having the flight safety of ALEP devices (in the absence of a laser system) evaluated prior to them being used in flight is often overlooked by unit safety officers and test engineers.”

“Newly developed ALEP and new manufacturer’s versions of fielded ALEP must be evaluated for overall lighting compatibility and flight safety.”

Different manufacturers use different dyes to protect against specific laser threats. The result may be vastly different spectral absorption characteristics for devices designed to do the same laser protective job. The result, of course, may be significant differences in colour perception for in and out-of-cockpit colour targets.

Although not strictly a colour vision issue, the authors warn: “Selective absorption of visible light by any type of optical filter can potentially affect target detection and/or lighting visibility and colour appearance.” The authors describe the interaction of polarising properties of an ALEP with polarisation from a cockpit canopy producing a variety of visual impairments including colour appearance.

“ALEP’s effects on easily transitioning from in to out-of-cockpit viewing should be examined.” The authors provide Table 9.1 for guidance.

“The effects of ALEP on performing different types of flight manoeuvres and mission-oriented tasks should be included in ALEP evaluations.” Of particular concern is excessive light scattering from some devices (i.e., glare) “when their flight profiles placed the sun within 30 degrees to 45 degrees of the centre of their field of view.” These concerns affect saturation of colour targets as well as overall visibility.

“In-cockpit lighting visibility and instrument and display visibility and readability should be closely evaluated with ALEP devices.” The colour appearance of indicator lights, heads-up displays (HUD) and head-down displays have all been adversely affected by ALEP devices. Of particular

concern are the symbology in various devices such as radar display patterns, emergency lights and emergency/threat display symbology.

## 9.2 SPECIALISED LABORATORY ANALYSES

There are a few special analytical tools that have been brought to bear in this arena. The specification of colour defects that are acquired may be aided by the use of unusual, but quite useful procedures. The FM-100 is often used to evaluate colour vision impaired by ALEP devices. Although the test was not designed for this purpose, it has served well. (Kuyk, Thomas, 1990)

Of particular interest are the influences that specifically affect the red-green and/or blue-yellow systems. By careful selection of the results for some of the FM-100 test caps, it is possible to estimate the impact of an ALEP on the two systems independently. The methodology is attributable to Smith et al. (Smith, Pokorny and Pass, 1985) who developed a technique that eliminates correlated variance by taking the difference between red-green and blue-yellow scores. An axis is determined and its severity evaluated. Age norms are available. The technique was originally used to show the evolution of a blue-yellow axis as a function of age in otherwise normal observers. It has since been used to evaluate tinted lenses and ALEP devices (Kuyk, Thomas, 1990). Clear cut evidence was provided that tinted appliances may produce moderate to severe colour vision defects, often tritanopic.

A more recent innovation is attributable to Vingrys and King-Smith (1988). In this case, the method will work with other panel tests such as the D-15 and the desaturated D-15. The FM-100 is however the test most typically employed. In short a moment of inertia analysis yields three factors that describe colour vision problems. First a confusion angle identifies the type of colour vision loss. A confusion index, usually called the C-index quantifies the degree of loss with respect to perfect cap arrangement. Finally an S-index defines the degree of polarity or freedom from randomness that exists. The procedure has been validated on a large group of normals, protans, deutans and those with acquired colour vision loss. The results were gratifying. In addition, the system has been used to evaluate ALEP devices with good results.

(Thomas, Garcia, 1993). The results provided a second line of evidence that some laser protective devices produce tritanopic defects. The battery of Smith and Vingrys, King-Smith analysis tools has become virtually standard in the business of determining the influence of appliances on colour perception. Both procedures are quantitative, have norms established and the significance of an error in colour perception may be quite clearly and adequately characterised.

## 9.3 PROSTHETIC COLOUR FILTERS

The flight surgeon may encounter another sort of device that has been proposed for use by colour defective observers. A special contact lens that is tinted red will make it possible for most red-green colour defectives to pass the standard pseudo-isochromatic plate tests (Paulson, 1980; Siegel, 1981). Again, the notion that a simple piece of tinted plastic may correct profound physiological and photochemical errors is specious. What, in fact, does happen is achromatic cues result from the use of the filter that permit the numerals in the test books to be seen. This is in no sense colour vision. The test calibration has been seriously altered and the test reduces to analysis by the observer of shades of grey which are visible. Great care should be exercised in testing facilities to detect the use of these devices used to elude detection of dichromacy. A sudden, miraculous improvement in test performance over time is at least one clue that something is amiss. Hereditary red-green colour deficiency does not improve; it is quite stable over time. Questions from commanders who don't understand the principles of colour vision test construction may be quite persistent and range from issues of using the devices to increase the number of pilot trainees, to those related to camouflage detection or use by special forces in air-sea rescue operations. It is not the case that colour vision is improved and the use of the devices should be discouraged.

## 9.4 NIGHT-VISION GOGGLES (NVG)

At least one definition of colour vision includes the notion of sensing chromatic differences. In common sense terms, that means "red" may be distinguished from "orange" or "green". Discriminations that depend on achromatic differences (no colour change) only involve

brightness. That is, “green” on “green” discriminations depend on brightness and not colour. NVGs are achromatic difference devices. They amplify the ambient scene illumination to produce and intensify a monochromatic view of a night-time scene.

Generation III NVGs have the greatest sensitivity in the visible. “Minus blue” or long pass filters are used to reduce the devices sensitivity in the visible and emphasise short wavelength sensitivity in the red and infrared. The actual colour displayed is green and is due to the phosphor used in the display device; a situation that is much like a black and white television set. The character of the “minus blue” filter is what differentiates the classes of NVGs from each other (Godfrey, 1991).

Because of the extreme short wavelength sensitivity of the device, “red” and “infrared” wavelengths may “blind” the device causing protective circuitry to be switched on resulting in the total loss of images. Proper coupling of the NVGs with the flying environment involves removing sources of short wavelength radiation such as “red” light emitting diodes (LEDs) and incandescent light. The latter is quite spectrally rich in the red and infrared part of the spectrum.

To combat blinding problems, the lighting used for parachute jumps has been switched from “red” to blue or “blue-green”. That process has introduced another problem related to visual function. Dark adaptation under “blue” light conditions is much less effective than under “red” light. “Red” light adaptation is very nearly scotopic and rod sensitivity is quite high. “Blue” adaptation is nearly photopic and rod sensitivity is quite poor. The result is a prolonged amount of time to go from “blue” adaptation to night vision when compared to “red” adaptation. If scotopic or even mesopic seeing is needed during a jump, it will take tens of seconds to minutes to achieve after “blue” light adaptation and only a few seconds when “red” adaptation is used.

The eventuality of “colour” NVGs introduces the complications seen with other sorts of colour displays, especially CRT based displays. The “colour” in these devices, while real, is actually pseudo-colour. That is, brightness levels are coded and colours are assigned on that basis.

The colour display problems described in the following section are similar or the same for these NVGs. Therefore they are quite real and deserve consideration.

## 9.5 CRT SCREENS

Although colour normals may appreciate several thousand colours, deuteranopes and protanopes may only appreciate twenty-seven and seventeen colours respectively (Pitt, 1935). When making absolute colour identifications, colour defectives are unable to discriminate more than two or three colours. Absolute identification involves identifying a colour in the absence of any other comparison colours. For most sensory modalities, six to eight absolute identifications are possible for normals. So, six to eight tones when played on a musical instrument or sound generator may be called out when no reference tone is available. There are many unusual characteristics of colour monitors and there are a few common characteristics that may reduce the performance of a colour defective using such devices. First, the chromaticity of the colours is not standardised from monitor to monitor. Modification of the chromaticities of a monitor are likely over time and CRT screens have been characterised by their instability (Cowan, 1987). In order to overcome these sorts of problems, calibration of the monitors is essential. However, there are a variety of methods that may do a good job or a poor job of characterising the colours produced by the device. The techniques are complicated, use special equipment, are time-consuming and are particular to the monitor in use (Post, 1992). These technological flaws will make the monitors difficult to use by any sort of colour defective.

There are three basic problems associated with CRT screens; doming, blooming, and shadowmasking (Cowan, 1987). Doming refers to shape distortion and is not of prime importance for colour vision requirements. However, glooming and shadowmasking problems affect the colour presented on the screen. Blooming produces desaturated colours and blurring of edges. Shadowmasking produces large areas of non-uniformity in colour or brightness. All of these difficulties are likely to increase the level of difficulty in interpreting colour coding for colour defectives.

## 9.6 REFERENCES

1. Cartledge, R., Thomas, S., Troxel, S., Kang, R., Keppler, K., Maier, D., Knisley and Garcia, P., Advanced Aircrew Vision Protection (AAVP): Interim Technology Transition Document AL/OEO, Brooks AFB, TX 1995.
2. Cowan, W., Colorimetric Properties of Video Monitor, Notes for a Short Course Presented at the Annual Meeting of the Optical Society of America. Rochester, 1987.
3. Godfrey, G.W., Principles of Display Illumination Techniques for Aerospace Vehicle Crew Stations, 1991, Aerospace Lighting Institute, Tampa, Florida.
4. Hovis, J., Lovasik, J. and Cullen, A., Physical characteristics and perceptual effects of 'Blue - Blocking - Lenses', *Optom and Vis Sci*, 1989; 66, pp 682-689.
5. Kislin, B., The use of yellow lenses in air force operations, SAM - TR-68-93, 1968.
6. Kuyk, T.K. and Thomas, S.R., Effect of short wavelength absorbing filters on Farnsworth-Munsell 100 hue test and hue identification task performance, *Optom and Vis Sci*, 1990; 66, pp 682-689.
7. Paulson, H.M., The X-Chrom lens for correction of colour deficiency, *Military Medicine*, 1980; 145, pp 556-560.
8. Pitt, F.H.G., Characteristics of dichromatic vision. Special Report, Committee on Physiology of Vision, London, 1935.
9. Post, D.L., Applied colour vision research. IN Colours in electronic displays. H. Weddel and D.L. Posts Eds., Plenum Press, New York, 1992.
10. Siegel, I.M., The X-Chrom lens. On seeing red, *Surv. Of Ophthal*, 1981; 25, pp 312-324.
11. Smith, V.C., Pokorny, J. and Pass, A.S., Colour-axis determination on the Farnsworth-Munsell 100-hue test, *American Journal of Ophthamology*, 1985; 100, pp 176-182.
12. Thomas, S.R. and Garcia, P.R., Physical and psychophysical evaluations of the FV-6 minus ruby and FV-7 laser eye protection visors, AL-TR-1992-0174, 1993.
13. Vingrys, A.J. and King-Smith, P.E., A quantitative scoring technique for panel test of colour vision, *Investig Ophthal and Vis Sci*, 1988; 29, pp 50-63.



## Chapter 10

### Current Colour Issues in Military Aviation

Douglas J. Ivan, Beatrice LeBail and Franz-Josef Daumann

The proliferation of multicoloured informational displays for use in aircraft and related areas, such as for air traffic control, has mandated the operational requirement for multicoloured discrimination to a level unparalleled in the basic red-green and white aviation environment of yesterday. The foundation for red-green and white colour recognition requirements in aviation arose from the long-standing traditional navigation systems employed in other modes of transportation such as with ships and trains. Thus, selection of early aircrew was historically based on the testing methodology and requirements established in those other industries, but has remained essentially unchanged up to the present day. Arguably, this approach has been quite effective with few colour-related major transportation disasters. However, the advent of multispectral displays has heralded the arrival of new aviation colour challenges and has changed all that.

There is good evidence in the scientific literature that more information can be communicated to a “normal” visual observer considerably more rapidly and effectively based on colour discrimination. This can be translated into reduced error rates and shortened reaction times. Such displays typically have redundant symbology to avoid obvious colour confusion and traditional linkages to established aviation ergonometics. However, the presence of redundant symbology does not always ensure enhanced performance. Furthermore, such multicoloured displays are based on the fundamental premise of a biologically “normal” eye and the assumption that it possesses full spectral discriminatory ability. The biological coupling of such devices with colour defectives has generally not been considered during their engineering development with rare exception. Generally, the colour-rich electronic display palette was selected for its visual glitz and because of aesthetically perceived identifiable differences based on obvious colour contrasted imagery. In many cases, the types of phosphors and diodes in existence at the time determined the technical expression of the equipment.

Since it is very difficult to understand, let alone simulate, all of the genetic varieties of colour defects currently identifiable in human eyes, it is virtually impossible to anticipate or engineer devices that accommodate all such defectives effectively. Nonetheless, some progress has been made in developing techniques that demonstrate the performance limitations of colour defectives, some of which are presented elsewhere in this publication. In addition, a selectable monochromatic redundancy mode is rarely incorporated into the design and presentation capability of information systems that exploit full colour. Since we don't exactly know how colour defectives perceive the normal coloured environment, attempts to accurately establish a comparative performance basis between colour normals and colour defectives in a variety of traditional aviation tasks have been elusive and scientifically unsatisfying. The differences, however, are accentuated when a performance deficiency results in a significant mishap.

The colour defective may not be fully aware of their performance limitations and may often regard themselves able to “see colours” and to be fully capable of performing satisfactorily and safely in their operational environment. However, in most cases, the recognition of “colour” in such individuals is not fundamentally based on traditional colour discrimination, but rather on a compromised spectrum and other cues, such as brightness discrimination, or in some cases, learned by trial and error.

It also must be remembered that although traditional aviation selection standards are based on broad categories of congenital sex-linked colour defects in 5-8% of males, acquired coloured deficiencies, from a wide variety of aetiologies, can degrade critical colour vision performance in a previously normal individual regardless of their sex. The onset of such acquired defects may be unpredictable and provides further justification for frequent monitoring or retesting of colour discrimination. Furthermore, it mandates that displays be designed that can either be fully

utilised by colour defectives or require that applicable colour defectives be screened out of any given population utilising such devices.

Many traditional scientific studies have documented the performance deficiencies associated with colour defectives. These deficiencies go well beyond actual colour hue recognition difficulties to impose other penalties that are not generally considered in the engineering process. For example, colour defectives must be significantly closer to a coloured target than normals in order to discriminate it based on colour information; they universally make significantly more errors compared to normals in interpreting such colour-based information; and they take considerably longer periods of time making a colour-based determination. Alarming, they even make significantly more interpretation errors when only white signals of varying degrees and brightness are involved.

Thus, simple recognition tasks based on red, green, white, or yellow cautionary lights or warning signals in an aircraft cockpit, although historically effective, are rather primitive when compared to new colour-based weather displays, multispectral cockpit information displays, multicoloured air traffic control displays and visual identification of colour logo based air and ground targets.

Operationally, we can categorise the colour environment and their demands into several general categories.

## 10.1 EXTERNAL NAVIGATIONAL AIDS

Navigational aides external to the cockpit remain consistent with the traditional red-green-white navigation systems whose foundations were within the other existing modes of transportation at the time. Although great variability exists regarding the configuration and types of lighting employed for those purposes around the world, virtually all runway lighting systems on land and sea are strongly based on red-green and white lights (Table 10.1 and 10.2). Such variations in these systems, however, also illustrates the need for further international standardisation efforts in this area. Although shipboard lighting systems differ configuratively from traditional airport lighting, the same basic traditional colours are employed (Table 10.3). There are a few instances when yellow and blue lighting are utilised, but overall

airfield lighting systems are strongly based on tradition, are relatively easy to discern, and have served the aviation industry well.

However, there are potential modern day disconnects or problems associated with the current approach. For example, introduction of selective waveband filters into the cockpit, such as coloured lenses and laser eye protection, can significantly alter the external colour world and disrupt the perception of these lighting systems. This has generally lead to the premise that such devices should not be worn during take-off and landing phases of flight. Operationally, it is unlikely that such filters would be required during these phases of flight, however, common selective waveband filters, such as blue-blocker sunglasses, "Shooter's" glasses, cosmetic tints, or visors such as the yellow USAF High Contrast Visor, are capable of significantly disturbing the colour scene.

One classic example of this involved a fighter aircraft attempting a landing on a partially closed runway, whose final approach had to be called off near touchdown by the tower personnel because the two crewmen, who were wearing the yellow visor at the time, were unable to see the large yellow Xs painted on the relatively achromatic grey background of the unusable portion of the runway upon which they were about to land, until they removed the visors. Nonetheless, some aircrew subjectively prefer this type of visor under certain conditions even though it has not been objectively validated. Regardless, such visors are not universally accepted and should not be worn for take-off and landing for the reasons cited above.

Effective red-green testing has insured that red-green colour defectives, severe enough to be outright dangerous using traditional navigation lights, have been selectively screened out. This seems to have been successful in avoiding many more potential mishaps related to navigation aide lighting problems alone.

However, compromised colour screening, such as occurs with cheating, improper testing illumination, or coaching, can result in severe colour defectives "passing" so-called qualification tests and being entered into the flying population. Many of these individuals have been identified later after having problems during flying training and eliminated, but many others have alluded

detection and remain actively flying with few reported problems at current levels of colour discrimination demands. On the other hand, aircrew who are identified much later in their flying careers, and who have been fortunate enough to stay out of problems in the red-green-white environment and amass thousands of “safe” flying hours, are extremely sensitive dispositions in some countries.

However, a few notable instances have occurred, which illustrate the kind of problems that can arise when colour screening methodology becomes compromised. One classic example involved an F-4 fighter aircraft flying in the local airfield pattern at night along with two other aircraft. The pilot of the F-4 suddenly perceived what appeared to be two diverging “white” lights at coaltitude that were “approaching” his aircraft and concluded that there was an oncoming aircraft. Several evasive manoeuvres to avoid the impending mid-air did not seem to alter his perception of the scene, such that regardless of what he did, the lights appeared to continue to diverge, strongly suggesting to him that a single aircraft was approaching and a mid-air collision was imminent. Both aircrew members subsequently safely ejected, and fortunately, despite the loss of the aircraft, there were no ground injuries. Evaluation of the pilot after the mishap revealed him to be severely red-green deficient, unable to pass any traditional red-green colour tests including those he allegedly “passed” to qualify to enter US Navy flying training. He subsequently admitted that he had been “helped” along the way during colour screening testing, but had also learned how to amazingly manipulate the FALANT lantern test to his advantage to allow him to pass and enter into flying training. He was in fact severely colour blind and was promptly grounded permanently.

It has also been recently learned that certain colour plate tests, such as those by Richmond Products and Beck Engraving, may be “passed” independent of colour discrimination skills by simply memorising the characteristic background dot distribution pattern which is different for each plate!

Other examples similar to these, but with less catastrophic results, exist, but generally speaking, such mishaps have been relatively few and far between. This may be attributed to the effectiveness of the past and current red-green screening methodology within a red-green flying

world and would likely continue as long as navigational aides remain basically only red-green and are not altered by externally worn optical appliances such as coloured filters.

Aeronautical maps used for navigation employ colour coding printing schemes that vary somewhat by convention and colour around the world. Such maps utilise a limited, but broader spectrum of colours beyond just red, green, and white, to include blue, yellow, purple and magenta. In many cases, colour defective aircrew can have difficulties appreciating all the colours involved. Such maps, and their electronic equivalents, are also significantly altered by selective wave band filters, enough so that within high threat environments, when devices such as laser protection will be required, information on these map and simulated map displays may be confused, diminished, or completely blocked by these appliances.

Thus, it is extremely critical that maps and displays are compatible with these appliances when they are needed. However, depending on the threat wavelengths blocked, this means that a multiplicity of printing solutions would be required to accommodate this problem. With many different threat wavelengths, this becomes more difficult and until laser protection issues are engaged operationally on a larger scale, such map solutions are unlikely to be driven by the current level of demand or concern. Nonetheless, this remains a potential operational disconnect in the future that will likely be even further aggravated by incompatibility differences between colour defectives and colour normal aircrew.

## 10.2 AIR TRAFFIC CONTROLLERS

The use of colour to provide key information for air traffic controlling duties is rapidly evolving. Monochromatic displays are being replaced by full spectral multicoloured displays at an ever-increasing rate. In addition, certain other key processes used by air traffic controllers to monitor both ground and air traffic, such as flight strips, weather radar, navigation lights, direct visual logo recognition, use traditional colour-based markers. Furthermore, many of the critical tasks being monitored using these techniques do not have any redundant back-up cues, therefore, recognition of the colours involved becomes primary and critical, and failure to do so correctly has the potential for catastrophic consequences. Recent studies by the

FAA and others have illustrated the point that all colour defectives regardless of degree, including mild anomalous trichromats, perform at significantly degraded levels compared to colour normals on a variety of critical colour-related tasks required in the air traffic controlling environment. Others studies suggest that mild deuterans (mild deuteranomalous) may be able to perform adequately in certain aviation environments. Regardless, multicolour displays have accentuated the differences in performance and these studies have highlighted the problem and generated considerable concern regarding the vulnerability of relying on current, and seemingly archaic colour vision testing methodologies and standards, for modern air traffic control duties. Since a full spectral palette of colour is utilised in these new displays, it is becoming increasingly clear that both full red-green and blue-yellow colour testing is necessary to ensure that the risk of critical mistakes based on colour deficits are minimised to as low a level as humanly possible.

### **10.3 OPTICAL APPLIANCE EFFECTS**

#### **10.3.1 Selective Waveband Filters**

A variety of optical appliances are currently utilised by aircrew for performance enhancement and ocular protective purposes. Among them are sun protection, contact lenses, tinted spectacles, nuclear flash protection, laser eye protection, and night-vision devices. Selective wave band (coloured) filters are routinely used for a variety of these optical tasks. No coloured filter can be placed in front of the human eye without degrading some aspect of the overall colour scene on the other side of that filter by reducing overall light transmission, altering colour contrast, or blocking selective wavelengths transmission. Such a scene alteration requires relearning the new colour world out in front of the individual. Although such coloured filters can be studied and their operational impact on colour normals evaluated and predicted, assessment of their effects on colour weak or colour abnormal individuals is extremely more difficult, if not an impossible task. Thus, when a certain selective waveband protective material is required, that also blocks certain portions of the visual spectrum, we induce a considerable colour penalty on that individual that translates into a major alteration in the perception of electronic colour displays, maps and the outside world. Even sunglasses, such as blue-blockers or

other fashion tints in vogue, induce significant alterations in the colour scene based on their ability to block certain portions of the visual spectrum selectively, such as purple and blue. This is also true of deeply pigmented contact lenses. Such devices create significant disconnects between the operator and the colour scene before them. Ground targets can become indiscernible; certain camouflage schemes on aircraft can render them more difficult to detect or even invisible under certain contrast and background conditions.

Since laser protective technology is an emerging area of science, there are limited scientific studies available that demonstrate the effects of these visors across the full spectrum of current aircraft related displays. With each new laser threat, a new selective waveband filter is formulated to counter it. Each must be operationally evaluated and each will induce profoundly different effects, particularly unpredictable on colour defective aircrew. These effects occur across the entire colour spectrum and the impact of such effects must be considered across the full capability of the aircrew member, not just by red-green screening tests, but unfortunately few aviation communities utilise blue-yellow screening methodologies.

Although much of the laser protection technology remains classified, it has been easily shown that selective waveband filters, particularly laser protection materials, induce significant performance penalties on aircrew-related tasks. Error rates increase and in many cases, symbology size must be increased considerably in the laboratory, by as much as 50%, to variably recover or offset such effects. In many instances, this is not, nor will it be possible, to fully compensate for. Furthermore, current electronic displays do not offer an alternate mode or default option that compensates for such operationally induced filter effects.

In many cases, a monochromatic display, if properly selected, would be more advantageous by neutralising the induced colour disturbance; however, aircraft system design trends are away from such monochromatic displays and towards multispectral displays which have not incorporated corrective alternatives.

The virtual cockpit environment of tomorrow is even more likely to depend on colour-based information than currently imagined. Thus, any aircrew appliance that acts as a coloured filter

carries with it the potential to deleteriously impact visual performance during critical aviation-related tasks. This is the fundamental reason why only neutral density (colour neutral) grey colour, which permits a reduced, but unaltered visible spectrum, to be transmitted through it, is preferred for aircrew sun protection.

### 10.3.2 Night-Vision Devices (NVDs/NVGs)

The integration of NVDs and NVGs into air operations has introduced a plethora of new physiologic and equipment interface issues. In effect, NVDs may be thought of in the context of biologic coupling, introducing a complex blend of aerovisual and engineering factors. A great deal has been written regarding the use of NVDs by aircrew; however, we still are relatively naive in such issues as NVD performance nomograms and visual standards, the impact of NVD performance as a function of ocular pathology, physiologic/optical interphasing, and other essential NVD neurobiological coupling issues such as colour perception. At present, the performance of aircrew with NVDs with respect to an underlying colour deficiency has not been evaluated. The emission maximum for the generic night-vision goggles (NVG) is 530 nm; the wavelength maximums for red and green cones are 546 and 571 nm, respectively. Thus, it theoretically would appear that neither cone system is maximally stimulated and it might be concluded that the chromatic system may not be optimally coupled to these devices. However, the luminance levels generic to current monochromatic NVDs/NVGs appears to override any apparent or theoretical wavelength disconnects in colour defectives.

As greater reliance is placed on colour-coded NVDs, optimised neurobiologic coupling in colour-normal individuals will need to be pursued and standards may become necessary to ensure there is no performance degradation with these severely visual-tasking devices in colour defectives. This issue raises a potential disconnect that should be avoided or engineered out of the system, until studies permit a better understanding of NVD colour coupling in colour normals and colour-weak/abnormals. How much simpler it would be to neurobiologically couple future NVDs without having to consider a multitude of biological subsets in the process.

The aeromedical and operational communities are aware that there appears to be a normative range in

best possible achievable visual acuities through NVDs, that surprisingly does not correlate directly with best corrected visual acuities. For example, a 20/15 eye may not be capable of performing to the same level of visual efficiency through night-vision devices as another 20/20 eye. Many variables probably influence this performance disconnect and are yet to be delineated in this relatively new emerging visual performance arena. Similarly, the impact of a variety of ophthalmic conditions and medications that disturb cone physiology and function have not been evaluated with respect to their impact on night-vision goggle performance levels. The phosphors chosen for NVGs were based on available tube technology, independent of ocular physiology. Therefore, the tubes were not intentionally designed with optimised biological coupling or human ocular physiology in mind.

Such studies are critical with respect to understanding the operational constraints of such devices and the development of qualification standards that ensure optimal mission performance.

## 10.4 TARGET DISCRIMINATION

### 10.4.1 Air-to-Ground Operations

Despite exclusive initial night strikes using night-vision devices, the Gulf War demonstrated that surgical daylight strikes continued to be a prominent part of tactical air operations, and are likely to be more so for the foreseeable future. In this context, map reading tasks, visual target confirmation, and smoke marker detection are greatly enhanced by, if not totally dependent upon, an intact colour vision system. These tasks become extremely difficult, if not impossible through optical devices, such as laser eye protection (LEP), which have a variable impact on colour normals and an unpredictable one on colour abnormals. Although some selective waveband filters may “enhance” detection of a particular colour range, this advantage is accompanied by a greater loss of discriminatory ability in other colour ranges and a reduction in overall luminance. This creates a new colour scene and induces new challenges. Thus, although a coloured lens may facilitate identification of a particular colour under certain conditions, such as a Day-glo or yellow life-raft, it does so by decreasing both the overall colour and intensity of the rest of the visual scene. The newly altered colour world has to be “relearned” rapidly,

often under duress; information processing times would be prolonged, processing errors increased; and a colour defective's performance time may be degraded disproportionately, compared to a normal and depending on the visual task involved.

### 10.4.2 Air-to-Air Operations

Despite technological advances in long-range missile intercepts, visual identification of potential hostile aircraft, particularly in politically sensitive situations and because of the fact that not all missiles hit their intended target (only 20% in actual combat), will still currently dictate the need for positive identification and the potential for close-range dog-fighting capability. Recent tragic friendly fire events in Iraq, involving the shooting down of two Blackhawk helicopters by two "friendly" F-15s, has heightened awareness of the requirement and renewed the vigour for positive visual identification in such extremely crowded and politically charged air operations. When electronic identification is not helpful and sensitive political or potential career-ending decisions arise, positive visual ID becomes pre-eminent. This is compounded by the fact that nowadays similar aircraft are flown by many different nations and even adversarial aircraft are aerodynamically visually very similar. Paradoxically, aircraft identification markings, such as flags and roundels, although very different, remain quite similar in basic design and coloration. Such markings typically are quite small and frequently remain unrecognisable at a "safe" viewing range. In many cases, such markings are deliberately subdued to actually deter visual identification, yet still remain compliant with international standards. Positive visual identification of such symbology may constitute an operational requirement under certain rules of engagement and places such aircrews at considerable greater tactical risk. Trying to avoid such a predicament was at the very heart of the Blackhawk helicopter shutdown tragedy. Colour defective aircrew would need to move even significantly much closer to such colour-based symbology in order to discriminate it, and in some cases, may still not be able to do so because of the basic colour defect, either induced or inherent in the individual aircrew member.

Despite the existence of an international treaty that bans intentional blinding laser weapons, the tactical offensive employment of airborne lasers that may, as a consequence of their use, dazzle or

incapacitate an adversary will still dictate dependence on laser eye protection in the air and on the modern battlefield in the future. Not all laser-based weapons, however, violate this treaty, and some adversaries at war may choose to operate outside acceptable international codes of conduct, as has been demonstrated throughout military history.

A pilot's ability to discriminate adversarial aircraft in close proximity against a background of varying colour contrasts and despite creative camouflage schemes makes visual identification even more difficult through such devices. In some cases, neutral grey aircraft against a low-contrast surround may be rendered seemingly invisible through certain visors, not to mention the fact that they may be extremely difficult to see with the naked eye alone. Such is the nature of visual camouflage, the hunter, and the hunted.

Recent and future military operations will remain critically linked to successful day and night refuelling operations. Although existing aerial refuelling tankers may utilise light tracks that employ redundant symbology and only red, green and white lights, coloured nozzle and boom markings on certain tanker aircraft add other visual challenges. Throw in a possible requirement for laser protection because of the proximity of hostilities to the refuelling operations and fatigue from sustained military operations or repetitive night-flight taskings, it can then be quickly appreciated how colour serves to reduce the stress and difficulty associated with such visual tasks.

## 10.5 AIRCRAFT CARRIER OPERATIONS

### 10.5.1 US Navy

Naval air operations, especially aircraft carrier based, present additional unique and critical colour-recognition tasks. These tasks often require exquisite choreography between aircrew and deck crew who wear colour-coded ensembles to help identify their flight deck responsibilities. Extremely hazardous, time-critical night carrier landings, although not totally dependent on colour discrimination because of automatic landing light systems, are greatly improved by the aviator's ability to discriminate colour cues and assimilate landing information rapidly. Coloured lights are important to delineate aircraft carrier superstructure and provide orientation during night

recoveries. This is not to say that night landings cannot be accomplished by colour-weak individuals, but this extremely critical phase of flight, characterised by an extremely impoverished visual environment, a very narrow window of opportunity and a paucity of acceptable alternatives is greatly enhanced by visual clues provided by intact colour discrimination.

US Navy aircraft carrier flight operations are governed by the Naval Air Training and Operating Procedures Standardisation Program (NATOPS) (NAVAIR 00-80T-105) which standardises both ground and flight procedures related to aircraft carrier operations. These operations are characterised by time-critical signalling procedures that are extremely well choreographed and differ significantly with respect to day versus night operations. These signals serve to minimise deck radio communication and facilitate direct control through visual cues. Thus, there is a strong reliance on hand signs and lights to communicate the status of all critical phases during such operations. During daylight procedures, deck personnel wear specific colour-coded shirts or jerseys to directly communicate their function to all deck supervisory personnel and aircrew (Table 10.4). Aircraft carrier lighting systems and their colours are listed in Table 10.5.

- a. **Launching Aircraft:** During the day, taxiing and launch procedures are handled with a combination of hand signals and lights. At night, lights become extremely critical. The catapult officers' console maintains the status on related air-launch activities and depends on red/green/white lighting. Aircrew communicate their status by turning on or off the aircraft navigation lights. The traditional "thumbs up" sign is replaced by a green light wand, held in either a vertical or a horizontal position by deck crew. Basically, this phase of the air operations is governed by only red/green/white lighting requirements.
- b. **Aircraft Recovery:** Red/green signal lights and beacons serve as the primary communication visual reference during day and night recovery operations. The meatball or "ball call" lighting display at the aft end of the flight deck is the primary instrumentation, and is composed of red, green and yellow lights. Other communication lights such as the Aldis lamp (red-green-white) and Verey (red-green-white-yellow-blue) are used as ground-to-air

signals. Some of these lamps, in particular the Aldis, can be difficult to see at greater distances and have a narrow angular viewing corridor. A laser-based system, to replace the current lighting of the ball, is currently under test and development to facilitate aircraft alignment at even greater distances, particularly at night.

- c. **Other Operations:** Lighting used for aerial refuelling relies on red, green, yellow and white lights and redundant symbology. A green flashing light on naval tankers indicates that a tanker has fuel and is ready for transfer. Sea-dyes used for search and rescue are either yellow or yellow-green (fluorescein). Day-glo orange is also used. The need to critically discriminate colour-related air-to-ground targets or to identify aircraft in pre-deployed politically constrained operational naval environments biases the need for normal colour perception to facilitate target recognition.

## 10.6 SEARCH AND RESCUE

Search and rescue operations are associated with a wide variety of colours to facilitate recovery, especially under peacetime conditions. Within hostile theatres of operation, efforts are made to mute vivid colour clues and a stronger reliance is made on more covert means of identification and location. Since colour plays its greatest role under non-hostile conditions, this issue deserves the greatest attention. Under these circumstances, colour contrast within the operational surround is exploited. Examples of this are yellow life-vests; Day-glo orange rafts, dyes, and materials; fluorescent sea dyes in a variety of colours; and fuchsia raft covers, to name a few. Although signal flares are generally red, green or white, blue is often used to distinguish strobe beacons from live gunfire. Several colours of fluorescent sticks are available for similar purposes and include: green, yellow, red, purple and blue. The choice of shorter visual wavelengths, such as blue or purple, are probably the least effective wavelengths to use with the unaided eye because of reduced physiological retinal sensitivity, reduced contrast, reduced luminance, scattering, defocusing and small field tritanopic effects.

The tremendous advantage associated with the use of night-vision goggles for search and rescue maximally extends the visible ranges of such

signalling devices. However, the choice of signal light wavelength is critical under such circumstances and obviously certain wavelengths can be used to optimise this capability, such as green, red or even infrared, while others such as blue and purple, may render them invisible to current night-vision devices or significantly compromise their effective visual range.

One might theorise that under certain conditions, a colour defective might have certain advantages over colour normals during search and rescue operations. However, matching this perceived unique “capability” with unpredictable conditions, negates many of the other signal device effect, and would be extremely limited and overwhelmingly deleterious. Therefore, under search and rescue operations, normal colour perception across the entire spectrum maximises the ability of the human sensor to visually acquire this type of target.

## 10.7 SUMMARY

For the reasons cited above and elsewhere in this Working Group report, the expanded use of colour in modern air operations, including military, commercial, and air traffic environments, has placed us at a decision cross-road regarding colour vision testing for these occupations. While it is true that the red-green testing methodology has been reasonably successful for decades, the past is prologue, and technology has now greatly expanded the role of colour in the modern aviation and the criticality of accurate full spectrum colour discrimination.

In virtually all aviation environments, the use of colour is proliferating. Within these same environments, the performance disabilities in colour defectives are becoming magnified which significantly raises the risks for catastrophic events related to colour information processing and related mistakes. These errors would potentially arise from misinterpretation of colour-based information, particularly under time restraints which further limits the integration of a series of interpretive tasks. In the presence of stress, such processing difficulties are likely to become significantly magnified and potentiate existing colour-based performance deficiencies.

Thus, it appears that more stringent and comprehensive colour testing to embrace both blue-yellow and red-green testing is indicated. Colour testing based on operational requirements

rather than genetic or laboratory tests that are difficult to correlate with real world tasks is highly desirable. An example of such an occupational test, PROCOPAT, is described elsewhere in this technical report.

Furthermore, such testing should be repeated frequently to avoid the consequences of acquired colour deficits and to avoid selecting colour defectives, even including “mild” colour defectives, for critical colour-dependent tasks that would ultimately threaten flying safety and operational effectiveness.

## 10.8 REFERENCES

1. Adams, A.J. and Tague, M.K., Performance of Air Traffic Control Tasks by Protanopic Color Defectives, *Am J Opt Physiol Opt*, 1985, 6, pp 744-50.
2. Bergman, H. and Duijnhouwer, F., Recognition of VDU presented Colours by Colour Defective Observers, Proceedings of the Human Factors Society 24<sup>th</sup> Annual Meeting, 1980, pp 611-615.
3. Cole, B.L. and Vingrys, Are Standards of Colour Vision in the Transport Industries Justified?, Report to the Australian Department of Aviation, July 1985.
4. Kuyk, T.K., Veres III, J.G., Lahey, M.A. and Clark, D.J., The ability of Protan Color Defectives to Perform Color-Dependent Air Traffic Control Tasks, *Am J Opt Physiol Opt*, 1986, 63, pp 682-686.
5. Kuyk, T.K., Veres III, J.G., Lahey, M.A. and Clark, D.J., Ability to Deutan Color Defectives to Perform Simulated Air Traffic Control Tasks, *Am J Opt Physiol Opt*, 1987, 64, pp 2-10.
6. Mertens, H.W. and Milburn, N.J., Performance of Color-Dependent Air Traffic Control Tasks as a Function of Color Vision Deficiency, *Aviation, Space, and Environmental Medicine*, Oct 1996, 67, pp 919-927.
7. Thomas, S.R., Aircrew Laser Eye Protection: Visual Consequences and Mission Performance, *Aviation, Space, and Environmental Medicine*, May 1994, 65, pp 108-115.



## 10.9 ADDITIONAL READING

Boynton, R.M., Human Color Vision, Holt, Rinehart and Winston, New York, 1979.

Porkorny, J.S., Verriest, V.C., Guy, and Pinckers, A.J.L.G., Congenital and Acquired Color Vision Defects, Grune and Straton, New York, 1979.

Porkorny, J.C., Howett, B., Lakowski, G., Lewis, H., Moreland, M., Paulson, J. and Smith, V., Procedures for Testing Color Vision: Report of Working Group 41, National Academy Press, Washington D.C., 1981.

Widdel, H., Post, D.L., Grossman, J.D., and Walraven, J., Color in Electronic Displays, Plenum Press, New York, 1992.

**Table 10.1: Airport lighting (USA/Canada)**

FACILITY TYPE	COLOURS	COUNTRY
High Intensity Approach Light System (ALSF-1)	Red/White/Flash	USA/Canada
High Intensity Approach Light System (ALSF-1)	Red/White/Flash	USA/Canada
Short Approach Lighting System (SALS)	Red/White/Flash	USA/Canada
Simplified Short Approach Systems (SSALR)	Red/White/Flash	USA/Canada
Runway End Identifier Lights (REIL)	White/Flash	USA/Canada
Visual Approach Slope Indicator (VASI)	Red/White	USA/Canada
Precision Approach Path Indicator (PAPI)	Red/White	USA/Canada
Tricolour Visual Approach Slope Indicator	Green/Amber/Red	USA/Canada
Alignment of Elements	Black/White or Fluorescent Orange	USA/Canada
Pulsed Light Approach Slope Indicator (PLASI)	White <steady/pulse Red < steady/pulse	USA/Canada
High Intensity Runaway Edge Lights (HIRL)	White/Last 2000' Amber	USA/Canada
Medium Intensity Runaway Edge Lights (HIRL)	White/Last 2000' Amber	USA/Canada
Threshold Lights	White	USA/Canada
Runway End Lights	Departure = Red Incoming = Green	USA/Canada
Runway Distance Markers	White on Black	USA/Canada
Runway Centreline Lights	White: Red/White: Red	USA/Canada
Touchdown Zone (TDZ) Lights	White	USA/Canada
Taxiway Edge Lights	Blue	USA/Canada
Taxiway Centreline Lights	Green	USA/Canada
Runway Exit Signs	Yellow on Black	USA/Canada
Taxiway Guidance Signs	Yellow on Black	USA/Canada
Airfield Identification Beacons	Green, Green/White, Yellow, Yellow/White	USA/Canada
Wind Cones/Socks	Fluorescent Orange	USA/Canada
Obstruction Lights	Flashing Red Strobe White	USA/Canada
Closed Runway or Taxiway	Yellow "X"	USA/Canada
Runway Instruction Signs	White on Red	USA/Canada

**Table 10.2: Airport lighting (Europe)**

<b>FACILITY TYPE</b>	<b>COLOURS</b>	<b>COUNTRY</b>
High Intensity Approach Light System	Red/White	Europe
Low Intensity Approach Lights	White	Europe
Runaway End Identifier Lights (REIL)	White Flash	Europe
Precision Approach Path Indicator (PAPI)	Red/White	Europe
Threshold Lights	Green	Europe
Touchdown Zone (TDZ) Lights	White	Europe
Runaway Edge Lights	White	Europe
Runaway Centreline	White	Europe
Runaway End Lights	Departure = red Approach = green	Europe
High-Speed Exit	Green	Europe
Taxiway Centreline	Green	Europe
Taxiway Edge Lights	Blue	Europe
Taxiway Hold Lights	Red	Europe
Ramp Edge Lights	Blue	Europe
Ramp Centreline	Green	Europe
Ramp Hold Bar	Red	Europe

NOTE: Conforms to ICAO Standards

**Table 10.3: Shipboard helicopter landing lighting (NATO STANAG 1275)**

<b>FACILITY TYPE</b>	<b>COLOURS</b>
Touchdown Circle	White/Yellow/Circle
Reference line	White/Yellow
Forward Structure Floodlights	Red/Yellow/White
Hangar Top Floodlights	White/Red
Deck Surface Floodlights	White/Red
Maintenance Floodlights	White/Yellow/Red
Deck Status Lights	Green = clear deck Red = fouled deck Amber = intermediate status
Periphery Line	White or Yellow Line
Deck Handling Line	Yellow
Line up Approach Lights	Amber/White
Deck Station Lights	Green
High Intensity Line up Lights	White
Deck Edge Lights	Blue
Horizon Bar	Yellow/White
Flight Deck Line up Lights	White
Touchdown Spot	White/Yellow
Glideslope Indicator (wave-off)	Red
Homing Beacon	White
Ship Identification	White/Yellow

Related Documents: STANAGS: 1162, 1211, 1236, 1237, 1251, 3117, 3711.

**Table 10.4: Flight deck jersey colour coding on US aircraft carriers**

blue	chocks, chains, tractors (aircraft not under their own power)
brown	aircraft Crew Chief (one per aircraft), refer to as the Plane Captain
yellow	direct movement of aircraft, traffic director, arm/de-arm munitions specialists, flow of aircraft to catapult; deck monitor
purple	fuel personnel
green	catapult and arresting gear personnel
white	safety (green-cross), medical (red-cross)
silver	fire-fighters

**Table 10.5: Aircraft carrier lighting system**

Deck Edge Lights	blue
Runway Athwartship Lights	white
Verticle Dropline Lights	red
Runway Edge Lights	white
Runway Centreline Lights	white
Signal Wands	red, yellow, blue, green
Rotary Beacon Signal System	red, green, amber
Landing Area Status Light Signal System	red, green
Safe Parking Line Lights	red
Axial Deck Bow Athwartship Lights	white
Floodlights	red, white, low pressure sodium
HERO Condition III Beacon	blue
Aldis Lamp	red, green, white
Verrey	red, green, white, blue, yellow
Fresnel Lens Optical Landing System (“Meatball”)	red, green, amber

**This page has been deliberately left blank**



**Page intentionnellement blanche**

## Chapter 11

### Colour Vision Concerns in Aviation

#### Clinical Concerns on Colour Coding in Aviation

John Firth

Aviation provides a microcosm of the wider use of colour in military, commercial and civilian practice. Colour vision has a number of dimensions other than the basic physical ability to detect wavelength, which itself may be compromised by congenital or acquired defects which in their turn may be static, transient or progressive. Colour visual performance is susceptible to physical, temporal, biological, coding and training constraints as well as the challenges posed by widely differing operational demands. What may be mandatory in one situation may not be appropriate for another. There are common principles but caution is warranted in the inflexible application of the requirements of one discipline throughout the whole spectrum of military, commercial, general, private and recreational activity. Critical situations exist in which colour may be denied. In providing colour redundancy there are lessons to be learned from those with colour deficiencies who nevertheless have made their careers in and contributed to every area of aviation.

#### 11.1 INTRODUCTION

For practical purposes vision is based not on one but on two functional systems. One of which supports colour. Colour vision, hue or visual electro-magnetic spectral frequency sensitivity is one dimension of vision and perception.

The first functional visual system accepts stimuli from throughout the whole visual field accessible to the eye. It has a low threshold, is movement sensitive and responds to luminance but not to colour. In effect it is only black/white or grey-scale sensitive. Operating at the brain stem level, the responses it elicits are simple, coarse and above all, fast. Whilst a powerful contributor to overall visual performance, this system is not part of the subject of this Working Group.

The second system provides colour and detail. It receives stimuli only from the central visual field, from that narrow cone about the visual axis which is subserved by the fovea. Because of the

richness of the visual information available and the widespread connections throughout the brain required for its processing, reactions evoked by this central field system take time.

Compared with the simple, prompt, compelling responses evoked by the “brain stem” system, this second “cortical” system’s threshold is high and generally its responses are slow. In return, though its response time is prolonged, resolution, both spatial and for colour is good. Provided, that is, that visual acuity ensures the sharp retinal image required for the former and light availability and transmission, afferent fidelity and retinal colour sensitivity are adequate for the latter.

Visual acuity, visual detail discrimination, is relatively easy to assess. Impairment and decrement are apparent to the subject, pilot, operator and test conductor alike. Correction is the rule. Light transmission to support that acuity is largely a function of ambient light together with corneal, lenticular and ocular media transparency. Opacity is manifest to both the effected individual and his/her medical attendant.

Paradoxically, though an individual’s colour visual competence is also a physical ability, variation in that ability is less obvious. One may be colour competent [“normal”], colour-blind or suffer degrees of colour incompetence between those extremes.

Colour visual performance at any one time is determined by congenital, physiological and environmental factors. The latter two ensure that even those with normal colour vision are subject to acute, recurrent and variable degrees of colour vision impairment. These may be acquired, pathological, potentially permanent but insidious and progressive. They may also be transient, induced, reversible and physiological, reflecting the colour limitations of the human visual systems and operational realities.

For good historical reasons, colour visual ability has traditionally been judged in terms of simple

red-green discrimination. Where control of aircraft from the ground relies on red-green-white signals to ensure flight safety and operational effectiveness this was, is and will remain sensible.

But this simple requirement is now challenged. The “flying for all” lobby reason that for much recreational flying under daylight, visual flight rules, VFR, “normal” colour vision is not essential. Given these circumstances, theoretical insistence that the ability to differentiate red-green signals is the difference between safety and disaster is unrealistic. But it does ignore legitimate concern over the ultimate need for basic communication with non-radio air vehicles at landing sites and in the presence of other traffic. Should the disabled disable the able?

By contrast, in commercial aviation multi-hued colour EFIS, electronic flight information system displays have captured the market and all are convinced [sometimes for less than convincing reasons] of their worth. In busy displays or complex visual scenarios, colour adds a valuable further dimension. It allows slow, deliberate assimilation of much more visual information than is possible with monochromatic or grey-scale instruments. With training, automatic performance and pattern recognition appear to be enhanced. Once colour displays are experienced, few wish to return to “black and white” formats.

That the addition of colour to display systems is aesthetically pleasing is undoubted. That colour sells displays is manifest. That the colour dimension allows more information to be presented is indubitable. But whether that colour presentation is useful under those very circumstances, when the information contained in the colour-generated image is most vital, has been unquestioned, unexplored and unproven. Industry, the Services and the public at large have blindly assumed that because a set-piece sales demonstration looks “better” in colour, then by the same token it will perform better in acute situations when the display and the crew it has been purchased to serve both justify their existence. There are grounds to suggest that this may not be so and that all colour displays should, at least, have built-in colour redundancy as part of their basic design. Meanwhile the use of colour in reflex, automatic and sub-cognitive time domains (“microtime”) needs to be demonstrated and validated.

ATC, air traffic control, virtual cockpits and the remote pilotage of UAVs, uninhabited air vehicles

as well as the over-ambitious use of HMD, helmet-mounted displays can all suffer from the central field clutter which colour encoding invites. This in its turn distracts attention from the peripheral field, where the naturally powerful analogue motion cues of the real world are neutered by their digital representation. How well pseudo-analogue peripheral motion cues will perform in practice and whether they overcome this in-built guarantee of peripheral inattention in virtual operational environments remains to be seen.

Military aviation has become colour dominated when half the operational world is night. That is, monochromatic. Night vision requirements are only one of the many challenges to colour dependence at the man-machine, man-*melieu* interface.

Multi-sensor fusion, image generation for virtual cockpits and the representation of non-visual imaging modalities in NVDs, night-vision displays introduces a new dimension to visual synthesis. Ensuring that the ability to fight at night is not compromised by the introduction of colour to the “night-green” monochromatic world of current practice is an immediate challenge.

Commercial aircrew earn their keep by sorting the system when all else goes wrong. Environmental hazard, software and system failures, let alone hostile action induce acute situations in which there is little time for leisurely, cognitive appraisal of the problem and the available options. When time is measured in milliseconds, reliance on current colour displays may be misplaced. In exactly those situations when the information they contain is at a premium.

For the military, superagility, instantaneous changes in luminosity, glare, laser-illumination, eye-protection, biochemical, physical and physiological challenges all hazard colour vision and militate for colour redundancy in displays, cues and signalling. That colour may work at several levels does not mean that its use is necessarily confined to the cognitive, measured-in-seconds time domain. On present understanding, however, in acute situations reliance should not be placed on the colour content of present, orthodox colour displays.

In the selection of aircrew, airborne or remote, the potential future aces, upon whose cunning and intelligence the defence of realms will depend, may be colour defective. There is no established

relationship between colour and military, let alone commercial or civil competence. The future's essential heroes may not be "colour normal". Do we, dare we exclude the otherwise-best candidates on colour competence alone?

Beyond these present concerns, colour competence is now more than red-green discrimination. Though apparently adequate colour stimuli may be presented by displays or other signal sources and an individual's colour discrimination on traditional red-green colour testing may at one time in the past have been shown to be satisfactory, whether or not EFIS and multi-hued colour images are perceived or interpreted correctly, let alone acted upon appropriately, is dependent on many more factors, both external and internal.

These include:

- Blue-yellow colour competence.
- Ambient illumination stability.
- Afferent signal architecture, power and profile (both temporal, spatial and spectral).
- Pre-signalling or isolated stimulation, "from cold".
- Signal position, static or dynamic, on or off the visual axis.
- Eye and head movement.
- Retinal colour sensitivity prior to and during signal reception.
- Signal-induced change; retinal and optic nerve transmission, brain stem conditioning, visual radiation and association tract function and eventually visual cortex and associated area colour processing. Though the latter is predominantly calcarine and occipital, magnetic resonance spectroscopy, MRS and functional magnetic resonance imaging, MRf, indicate that widespread, frontal and limbic system involvement is essential for "normal" visual function in the operational sense.

Not surprisingly this complex network is slow to produce an organised response. Its very complexity provides multiple opportunity for potential or actual, fixed or transient incapacitation. For simplicity these can be defined as static (fixed), progressive (increasing) or dynamic (transient), as shown in Table 11.1.

**Table 11.1: The nature of colour vision incapacitation**

Type	Transient	Progressive	Static/fixed
Congenital	–	–	+
Acquired	+	+	+/-

In aerospace practice congenital red-green deficiency is static and relatively easy to detect at selection using Ishihara or similar pseudo-isochromatic plates, PIPs. Blue-yellow deficiency testing is less well served by available tests. Later developing congenital defects do occur but most are associated with other features which render selection for aircrew status unlikely.

The rare late-presenting genetic colour deficiencies and the much more common forms of acquired colour deficits mean that colour vision testing at aircrew selection cannot be relied upon to ensure adequate colour vision throughout a flying career.

Acquired deficits occurring after selection, often develop insidiously and frequently remain undetected until attention is drawn to them by an incident or accident. To compound the problem, transient deficits may only be present under or induced by particular operational conditions. This may or may not be apparent to the individual at the material time or detectable by the demonstration of static competence on subsequent ground testing. By the same token, colour testing as part of routine medical review may not identify all in-flight, operational colour impairment. But a combination of simple, convenient and reliable red-green and blue-yellow testing, integrated with present routine medical assessments, backed by the informed medical surveillance of air operations would clarify most present uncertainties and, in a world committed to colour displays, minimise their hazards. This is one of the fundamental issues WG24 addressed.

## 11.2 SPECIFIC THREATS TO COLOUR VISION PERFORMANCE

### 11.2.1 Congenital

Epidemiologically, in the general population, 1:10 males and 1:200 females are colour vision deficient to a greater or lesser degree. Major deficit has been addressed since aviation medicine and

aircrew selection began. However a combination of relatively minor colour deficiency with particular operational conditions may enhance the problem in individual aircrew. The effects of +/-Gz, hypoxia and hypoglycaemia on minor degrees of colour deficiency has yet to be demonstrated.

Drusen (Sanders T.E., Gay A.J., Newman N., 1971; Spencer W.H., 1978; Tsao M.O., 1981) is not always the benign anomaly most believe. A Family History of visual impairment should be sought. Detection may still not be possible at initial selection and it remains (in Type I & II haemorrhages) a cause of subtle colour distortion.

“Small disc disease”, with crowding of the optic nerve head may present as anterior ischaemic optic neuropathy, AION or remain asymptomatic with the development of subtle changes in monocular colour acuity. Though initially usually unilateral, the propensity for later involvement of the other eye requires careful, individual review and surveillance.

Of the hereditary optic atrophies only Lebers is likely develop after selection, again initially unilaterally and in the 20s (Kjer P., 1956). Waadenberg's (1948), Krabbe's, Leigh's and the optic atrophies associated with hereditary ataxias all present before the age of pilot selection.

### 11.2.2 Acquired Colour Deficit

In practice acquired colour deficits may be transient, fluctuating, fixed or progressive. Their causes are largely physical, physiological or pathological.

#### Physical Threats to Colour Vision

Many operational conditions can impair or distort colour vision including:

- Gz, vibration (effecting displays and oculo-orbital harmonics as well as influenced by critical damping);
- fractured, rapidly fluctuating ambient illumination (as in a rapidly manoeuvring, agile aircraft);
- glare, direct or reflected;
- after-images;
- photo-toxic irradiation; and
- laser illumination.

Low luminosity, pupillary reflex lag and delayed night-vision acquisition are now compounded by vision-protecting filters. These reduce display colour signal strength and distort the colour spectrum, unless the visual information is delivered “inside”, behind the filter in HMDs, helmet-mounted or as a virtual display.

Whilst current filters are largely passive, static, broad band, neutral or wavelength specific (as in tri-stimulus filters), mimicking one-way mirrors, variable, energy gated (“power window”), smart dynamic filters are under development which will have protean effects on the colour spectrum transmitted through to the eye.

More sophisticated active filters, input driven reflectors, vector reflectors and photon processors (whether traps, gates, “windows” or “fences”) will complicate the situation and further compromise reliance on stable colour images.

#### Physiological Threats to Colour Vision

Under operational conditions many physiological factors may raise colour thresholds or reduce colour stimuli to sub-threshold levels. They include:

- cerebral ischaemia, hypoxia and hypoglycaemia complicating +Gz;
- sub-liminal stimulus exposure, power, wavelength, temporal and angular profiles;
- central field movement insensitivity;
- pre-signalling and conditioning;
- signal wave length/colour mis-matching and poor colour contrast;
- central field saturation and clutter by multiple, conflicting or competing colour stimuli;
- reticular system status (arousal/somnolence, Yerkes-Dobson-style);
- conflicting and out-of-cockpit targets;
- defocusing;
- clear sky myopia; and
- presbyopia.

The small and variable size of the colour field is compounded by colour field inhomogeneity, relative scotomata and out of central field, extra-foveal colour stimulation.



Inattention is no less a problem in colour vision than elsewhere in sensory physiology. Fatigue, “break-out” (high altitude hypostimulation/somnolence) and distraction are compounded by involuntary, slow pursuit/analogue target visual capture, brain stem system mediated reflex deviation and startle.

Colour in displays imparts so powerful and emotional effect that distraction from the real world may progress to misconception and misappreciation of critical situations, this in its turn enhanced and re-enforced, propagating mistaken preconceptions based on prior *trompe d’oeuil* which colour makes all the more compelling.

Visual input is suppressed, vision is actually interrupted by saccadic suppression during voluntary or reflex eye movement. Colour “breakthrough”, visual system stimulation during saccades can be achieved by enhanced and directed colour stimuli, but whether this can be turned to advantage is unclear.

Colour vision fidelity is also subject to harmonic suppression by frequency and wave length intercepts of conflicting stimuli, metacontrast, field edge effects, jamming, interference and receptor organ saturation by multiple inputs or supra-maximal stimulation.

The protean pharmacological hazards to colour vision are dealt with in Chapter 5.

### **Pathological States**

Most mistakes are made following failure to elicit a full history backed by careful clinical examination. Imaging and the available tests have neither the sensitivity nor specificity to provide the basis for aircrew clinical management.

Following trauma, whether it be aviation-related due to impact, ejection or blast, or suffered elsewhere, most commonly in transport or sporting injury, colour vision effects are usually obvious and part of ocular or head injury. But even when asymptomatic, any injurious application of energy should be followed by inquiry and test for colour impairment.

Infection, whether purulent or viral, sufficient to effect vision is usually incompatible with flight status. But in chronic sinusitis or obstruction altitude-related optic nerve distortion may occur whilst infestation can present with cortical visual dysfunction and subtle dyschromatopsia.

Early supra-sellar extension of pituitary tumours, the para-neoplastic syndromes and the reticuloses may present with colour impairment, but field defects with the first and neurological, systemic and treatment-related effects of the latter usually ensure that colour vision impairment is initially a secondary issue, though of later concern to medical revalidation.

Among ischaemic and vascular conditions, post-viral vasoparesis, the sympathopareses and cardiogenic, drug or alcohol-induced systemic hypotension are usually accompanied by obvious epiphenomena. But impaired +Gz-tolerance on a return to flight status may be indicated by transient colour loss.

Of the vasospastic states migraine is the most widely recognised. Because of the guarantee in the past that any admission of “migraine” would deny entry to flight status, aircrew entry requirements discriminated against honesty. Aircrew do not freely admit to migraine, yet migraineous auras are a near-universal experience. Whilst migraine variants are often accompanied by overt visual symptoms, prodromal effects on colour vision and overall pilot performance have yet to be established.

Frank vaso-occlusion may be colour asymptomatic or visually ephemeral if due to anterior ischaemic optic neuropathy, AION complicating “small (optic) disc disease”, SDD. Transient visual disturbance, amaurosis fugax and transient ischaemic attacks in the under-40s are usually vasospastic and benign.

Carotid and vertebral arterial dissection may be spontaneous or post-traumatic in the under-40s. Often asymptomatic, transient visual disturbance may be the only clue. They are a common cause of stroke in the young. Once complete and stable the long-term outlook in all age groups is sufficiently good to allow consideration of medical revalidation for flying.

In the over-40s, transient, presumed ischaemic symptoms have an altogether more sinister import. They are managed as TIAs, with the same prognostic implications as stroke due to vaso-occlusion, thrombosis or embolism, until proved otherwise. The exception to this rule are lacunar infarcts in the under-65s, but they rarely present with only colour impairment.

Haemorrhage is almost invariably dramatic and involves the visual fields, rather than colour alone.

With the increasing proportion of female pilots the group of conditions lumped together as “benign intracranial hypertension” and presenting with headache, papilloedema and subtle visual impairment will increase. To date this has not been a significant colour vision issue.

Temporal Arteritis rarely develops before 55 years, but is a concern in senior aircrew in the prodromal, systemic and superficial arteritic phase.

Of the metabolic hazards to colour vision, diabetes, toxic chemicals (lead, mercury, styrene), exotic fuels, defoliants, tobacco and alcohol are the most obvious (see Chapter 5). Dietary deficiency and drug abuse may be overlooked, whilst the effects of Parkinsonism in its commonest manifestation, gross, chronic fatigue, is forgotten.

Multiple sclerosis, MS is the most frequent auto-immune condition in Aviation Neurological practice. Riddoch’s (1917) phenomenon may be mistaken for the normal cortical-brain stem dissociation when attention is drawn by peripheral, brain stem visual stimulation to small, essentially monochromatic aerial targets. Uhthoff’s phenomenon is rarely questioned whilst Pulfrich’s (1922) has specifically to be questioned because aircrew are understandably concerned that to report it would suggest mental derangement.

Optic neuritis, either retrobulbar or papillopathic raises difficulty. Though the diagnosis carries with it a <20% chance that this is the first stigma of MS, 80% will not develop other demyelination. Providing that visual and colour performance recovery meets the regulations it does not warrant permanent grounding or the withdrawal of a licence. But it is a diagnosis of exclusion and because of the enhanced risk of later demyelination elsewhere it requires subsequent careful colour visual surveillance lest insidious colour deficiency is the mode of relapse.

Though the maintained and demonstrated operational competence of ageing aces in some air forces indicates that age is physiological rather than calendrical, the challenge of age to colour vision is dominated by macular degeneration and cataract formation. The ageing pilot may follow Gaugin into his later colour aberrations. Though principally a problem of the elderly private pilot, they may be operating and dependent on sophisticated equipment. Caution, care, good humour and routine review are the key to diagnosis and management.

## **Symbology**

Response to acute situations occurs at the reflex (inherent, segmental, <0.2 sec, “seat of the pants”), automatic (learned but involuntary, 0.2-2.0 sec) and voluntary (cortical, cognitive, deliberate, >2.0 secs response time) levels. Symbology can facilitate accelerated appreciation and more rapid reaction, faster than simple pattern recognition. Even brain stem pathways are too slow to usefully exploit reflex responses, unless visual startle is the reflex mode employed. Sub-conscious, learnt symbols have a powerful emotional effect but their value in achieving accurate, reliable automatic responses in the acute aviation case has yet to be confirmed in the air. However automotive manufacturers, and in particular their sales’ forces are convinced of this ability. Missile evasion, hyperagility and off-boresight lock-on may be facilitated by such trained responses, which have lag or central delays comparable to the automatic responses involved in the riding of bicycles. Reflex temporal domains powerfully linked to the management of +1Gz acceleration. Whether this can be accelerated by colour signalling is uncertain.

When acute, accurate, appropriate response is NOT the priority, aesthetically pleasing coloured symbology impresses the relaxed purchaser. What has yet to be tested in the air or in court is the reasonableness of the assumptions on which this impression is based. That relaxed colour perception has any direct relationship to the acute appreciation, assessment and successful resolution of real world aviation crises remains to be established. Colour assists crews to optimise their operations, but what assistance it is to those caught by acute, unexpected, unforeseen and unfamiliar crises is uncertain. Consideration of the colour vision dimension of recent tragedies may shed light in this area. Certainly all air investigations should establish or exclude any contribution, for good or ill, that colour might have, should have or did make to that incident under review.

## **Colour Redundancy, Luminance or Grey-Scale Backup**

That the brain stem visual system covers the whole visual field, that it is fast, reflexly effective, black-white (grey-scale) and exquisitely analogue movement sensitive is established. From this the natural conclusion is that when speed, accuracy and the exploitation of electronic systems and cueing is mandatory, then visual input should be grey-scaled and analogue movement based. Yet in

present practice, pilots confronted with an acute situation, either of impending disaster or transient opportunity, are provided with displays which guarantee the slowest possible response and the maximal opportunity for error. Would taxpayers or airline passengers part with their tax or fares if this were public policy. To date the slow, studied, laconic response to all disaster and opportunity, popularised and successfully practised by Yeager et al has obscured reality. With Su-30+s and more agile missiles going into service with so many states, NATO must either address this reality or invite humiliation.

The immediate “quick-fix” is grey-scale or luminance redundancy of all colour displays. This eases the laser filter case problem and ensures that in the short term all that can reasonably be done has been done. This does not require new technology, being an early option on Airbus glass cockpit displays.

In the mid-term the apparent ability of red stimuli to penetrate saccadic suppression and by-pass central field delays warrants further definition and consideration of its operational relevance.

### Sizing

Helmet-mounted or projected displays allow sizing of stimuli beyond the limits of flat panel designs. Large, wide-angle stimuli allow the exploration of visual startle and pursuit as a display and control modes. The usefulness and colour coding of such practice remains conjectural.

### 11.2.3 Practicalities

Much in the colour world is the subject of opinion or conjecture. In other areas there is a confusing wealth of information. The first requirement is to establish that colour does improve the performance of aircrew and that the requirement for set colour vision standards to exploit that advantage is reasonable.

Red-green colour competence has proven valuable over the years. Until it is proven irrelevant [*pace* the Australian Courts] it is reasonable to retain it.

The present situation is more complex.

- The full colour performance of the current pilot population is unknown, even though they are subject to regular, routine and rigorous medical review.

- With the adoption of multi-hued EFIS colour displays the red-green, blue-yellow colour vision performance of all aircrew and those holding aviation licences becomes, *de facto*, a matter of legitimate interest and concern.
- So long as it is practical, requires no more than a minor addition to current routine, the sensitivity and specificity of any proposed testing is appropriate and the information gained is both valuable and available, then establishing current population colour competence is reasonable.
- But this immediately raises a problem. Adding Ishihara to routine medicals would not be a major imposition and would be expected to confirm maintained red-green discrimination in the large majority of pilots. But blue-yellow test plates are less satisfactory, as indicated elsewhere in this technical report. Validation, stability and availability are immediate issues. Likewise adequate back-up testing of greater precision would have to be available to ensure fairness in any case of dispute. This could be provided by PROCOPAT, but would be likely to require detailed ophthalmological review and Nagel (for red-green) and Moreland (for blue-yellow) anomaloscopes, FM-100 or both.

Full colour assessment, *ab initio*, would be prudent for all those considering spending time and money in the air. Some members of WG24 have produced PROCOPAT which is an example of an occupational test which may be appropriate for this purpose and is now available as part of the BLUE LAGON industrial colour vision project.

The potential contribution, for good and ill of colour to aviation incidents and accidents has yet to be established. Routine testing has to be backed by:

- Research to demonstrate, quantify and validate the contribution of colour to routine and acute aircraft operation.
- Consideration of the colour dimension in all incident investigations and reviews.
- The central recording and availability of routine testing and accident information. With the demise of the RAF Institution of Aviation Medicine and with the cooperation of the USAF School of Aerospace Medicine (Brooks AFB, TX), the establishment of such a database at that or some similar institution as a NATO-RTO programme is appropriate.

Once the colour capability of the present population was established, then a degree of stratification would have to be accepted, not to discriminate against honesty or against those who are performing at present perfectly satisfactorily despite any deficit that might be demonstrated.

That stratification would stretch beyond the immediate flying community to cover aircraft assembly, engineering and maintenance; ground and carrier deck handling; air traffic control; recreational flying out of controlled airspace or landing grounds, the use of controlled airfields and airspace, IFR flying on standard panels, EFIS and advanced military operations. So far, red-green competency has been considered sufficient, but not demonstrated as essential for all. Technical requirements also now demand blue-yellow competency which similarly may not be essential for all. An attempt to relate the variety of flying and related aviation activities to colour vision requirements and the potential impact on operations is presented in Table 11.2.

The sub-population with colour deficiency which will be exposed is a valuable resource in establishing alternative mechanisms in colour and visual perception. They may well hold the key to the visual enhancement of microtime performance which is central to several current programmes.

### 11.3 CLINICAL REQUIREMENTS

- Improved colour test methods, particularly for blue-yellow at screening, occupational and definitive levels.
- Define the place of colour in acute situations of high +/-Gz, microtime and afferent information saturation or clutter.
- Demonstrate the effects of +Gz, hypoxia and hypoglycaemia on minor degrees of colour deficiency.
- Match displays and protective devices to optimise visual performance under conditions of imposed colour deficiency (most obviously laser protection) and in parallel with this.
- Establish the performance of colour defectives under the same conditions. What lessons are to be learned from them?
- Quantify the practical performance of colour-deficient individual pilots already in the system and identify the basis of their [manifest] competence.
- Define the full colour vision status of those operating virtual cockpits and using spectral mapping and multi-sensor fused information in visual formats as a basis for the optimisation of the presentation and interpretation of that information in both night, superagile and remote pilotage/UAV operational scenarios.
- A central NATO/ICAO database to handle the information and provide access for appropriate research.

**Table 11.2: Aviation activities and equipment as related to colour vision requirements and consequences**

Activity	Equipment	Red-green Requirement	Blue-yellow Requirement	Effect of full colour compromise
Advanced military	EFIS+	Presumed	Presumed	Potentially significant
Commercial	EFIS	Presumed	Presumed	Potentially significant
Commercial & General	IFR (IMC), standard full panel	Presumed	Unknown	Potentially significant
Night, IMC, VFR ground-controlled and/or assisted	Standard panel +	Presumed	Unknown	Potentially significant
ATC	Mixed multi-hued, colour and monochromatic	Presumed	Presumed	Potentially significant
Daylight VFR recreational	Basic panel	Required but unestablished	Unknown	Potentially significant
Ground/deck handling	Colour coded	Presumed	Presumed	Potentially significant
Engineering	Colour coded	Presumed	Presumed	Potentially significant
Aircraft assembly	Colour coded	Presumed	Presumed	Potentially significant
Design and development	Nil to supra-EFIS standard CAD	Not considered	Not considered	Not considered

## Chapter 12

### Conclusions and Recommendations

#### All Contributing Authors and Co-authors

Some recommendations can be written on the use and testing of colour vision.

#### 12.1 TESTING RECOMMENDATIONS (see Table 12.1)

##### General Conditions Must Conform to the Instructions of the Test

As an example, pigment-based tests require:

- Illuminant C (or equivalent),
- All sources of extraneous illumination should be eliminated,
- A dedicated room without windows.

Monocular testing should be performed.

Administration distance must be appropriate for the specific test.

Luminance should be regularly calibrated.

Test instructions should be available at all times.

Handling of test materials should avoid 'fingerprinting' of plate and arrangement tests.

Timing is test dependent but must be adhered to if indicated. If not indicated, testing time is given as needed; that is, the time typically required by most evaluatees.

Storage of plate materials and other pigment-bases tests should involve avoiding unneeded light exposure. Materials should be kept in a 'cool, dark location' when not in use.

Frequency of examination should be annual or part of routine flying physical examinations in keeping with national examination practices. Nations should strive for international uniformity of standards.

#### 12.2 TESTS

##### Testing for Congenital and Acquired Colour Vision Defects is needed.

Existing test procedures are appropriate for each case.

Congenital defects are usually red-green and affect predominantly males. Acquired defects are typically blue-yellow, but can also be red-green, and affect males and female equally.

##### 12.2.1 Testing Congenital Defects

Depending on testing needs, a minimum test should include a screening test (ex: PIP) and if complete diagnostic is required, both an anomaloscope (NAGEL) and hue discrimination (FM-100) tests are required. In general, red-green testing should be done.

When **considering red-green deficits**, the following tests are recommended:

- Nagel anomaloscope is the 'Gold Standard'.
- Other tests to be considered are PROCOPAT, PIP (Ishihara, Dvorine, American Optical (original form), SPP).

##### 12.2.2 Testing Acquired Defects

When considering acquired defects, red-green and blue-yellow deficits should be tested. The following tests are recommended in addition to the red-green tests listed above:

- Moreland anomaloscope is the 'Gold Standard'.
- Other tests to be considered are PROCOPAT, PIP (F2, PIPII and PIPIII).

Blue-yellow incidence (acquired) is not well specified, but is probably much higher than suspected and is estimated to be between 5-15% of

the general population. Closer examination particularly in an older flying population seems appropriate (see Chapter 5 for related problems produced by drug side effects).

### 12.2.3 Relevant Tests

Particular colour testing is needed for specific job applications.

Air traffic controllers versus aircrew, for example, may have different occupational requirements. Tests should be adapted to the specific tasks required. Example: A task-oriented colour deficiency test is recommended. A good example is PROCOPAT which may be adapted to a wide range of occupations.

## 12.3 COLOUR SPECIFICATION

**Colour specification should always be in terms of CIE xyz system.**

At the present time, there are many specification systems that are practicable. Many are in terms of RGB, HSL units which have the disadvantage of being device dependant. This applies in particular to modern types of electronic displays.

## 12.4 ISO

ISO regulations are also recommended. Refer to Chapter 7 for details.

## 12.5 DISPLAYS - APPLIANCES

**Displays should be readable by all users.**

Colour displays should be such that colour defectives may discriminate luminance contrast.

Otherwise, users must be selected that are fully capable of utilising all aspects of the display.

If colour normals may be selected, redundant coding should be used to improve 'readability' by subnormal observers.

Colour displays should be designed in the context of colour vision impoverishment, for example due to wear of Laser Eye Protection (LEP) devices and other filtering devices (see Chapter 9).

## 12.6 ISSUES

### 12.6.1 Requirements - Present

At present, within the commercial and private aviation environments, for non-EFIS contexts, some degree of red-green discrimination is required. In particular, recognition of red-green signal lamps must be possible. That is, presently approved colour signalling devices must be discriminated by the pilot.

For EFIS displays environments, red-green and blue-yellow discriminatory capabilities are required.

The military environment has special requirements. That is, red-green and blue-yellow proficiencies are required due to the increased use of polychromatic displays and other operational requirements.

### 12.6.2 Requirements - Future

Three different aviation populations may be identified and dealt with differentially.

There are commercial, private and military aviation participants, each of which may have different colour vision requirements.

In the future, tests should be sought that stratify colour vision capabilities so that mild colour weaknesses are not disqualifying for some classes of aviators. The minimum requirement should include some degree of red-green discrimination.

However, in those circumstances where EFIS displays are involved, red-green and blue-yellow discrimination must be considered. It may be possible in the future to adjust the EFIS display to the colour vision needs of the individual crewmember, but until such design changes are incorporated, multicoloured displays require full colour vision discrimination ability.

Ground personnel (mechanics, assemblers, engineers, etc.) must be included in the colour vision stratification process.

### 12.6.3 Colour Use/Ergonomics

Colour coding should not interfere with legibility.

Ambient illumination ‘washout’ should be guarded against.

Integration with LEP devices must be incorporated anywhere colour is used (see displays appliances above).

Colour coding outside the cockpit may need to be revised in the future to improve signalling.

## 12.7 RESEARCH

**There is great need for a database encompassing the present population of aviators and aviation-related professionals to include:**

1. **Colour vision related accidents.**
2. **Colour vision related mishaps.**
3. **Near misses and near accidents that are suspected to involve a colour vision component.**

We have proposed that the Ophthalmology Branch of the School of the Aerospace Medicine become the curator and manager of this database.

We have to develop a plan for optimal database utilisation.

**There is need for the development of new tests:**

- To better stratify the population of normal and colour defective/colour deficient observers.
- Develop better methods of evaluating imposed colour vision deficits (for example LEP devices, NGVs, etc.).

### 12.7.1 Extended Research on Polychromatic Cockpit Displays

Further research should address:

- The relevance of colour in ‘acute’ aviation situations.
- Other visual dimensions that are more or less salient than colour in these circumstances.
- A better understanding of the performance of colour defectives in a colour-rich environment.
- The understanding of the effects of high-G on colour vision in normals and colour defectives.
- The parameters of impairment due to hypoxia in colour impaired observers.

- The influence of display vibration on electronic colour displays and colour perception.
- The importance of colour in virtual environments.
- The importance of colour coding in sensor information (pseudo-colour or ‘false’ colour) such as in NVGs, SAR. These applications involve luminance information that is encoded into a colour representation.
- Strive for harmonising international standards of colour coding.

**A central database concerning these issues is thought to be desirable.**

Table 12.1: Summary of WG24 colour vision testing recommendations

## NATO - RTO (AGARD) WORKING GROUP 24 “OPERATIONAL COLOUR VISION IN MODERN AVIATION”

FLYING CATEGORY	EFIS DISPLAYS	
	NO	YES
PRIVATE	REQUIREMENT: MINIMUM RELEVANT <b>RED - GREEN</b> DISCRIMINATION (MUST RECOGNIZE SIGNAL LAMP)	<b>RED-GREEN /                      BLUE-YELLOW</b> TESTING
		<b>RED-GREEN / BLUE-YELLOW</b> TESTING
		<b>RED-GREEN / BLUE-YELLOW</b> TESTING
COMMERCIAL		<b>RED-GREEN / BLUE-YELLOW</b> TESTING
MILITARY		<b>RED-GREEN / BLUE-YELLOW</b> TESTING
ATC		<b>RED-GREEN / BLUE-YELLOW</b> TESTING

**CURRENT**

**RECOMMENDATIONS:**

• **PENDING INCORPORATION  
 OF COMPLETE COLOUR-  
 REDUNDANCY**

**OR**

• **COLOUR DEFECTIVE  
 DISPLAY MODES**



## Appendix 1

### Basic Concepts and Terminology in Colour Engineering

Jan Walraven

The application and specification of colour-coded (cockpit) displays is not possible without some background in colour engineering. Some of the basic concepts are discussed, followed by an overview of the most relevant definitions of perceptual, colourimetric and photometric terms.

#### A1.1 INTRODUCTION

Whenever colour is used, for whatever application, there always is a need for specifying the colours to be shown on the display. This may sometimes seem confusing, because colour has a variety of dimensions that bear on physical as well as perceptual aspects of this medium. For example, terms like intensity, luminance, brightness and lightness are still used indiscriminately, and often specified in wrong and archaic units like footlamberts and apostilbs.

In the following, some concepts and terms will be discussed that relate to the most basic physiological and physical aspects of colour. It is a first step in making the aviation community a little bit better acquainted with the multi-disciplinary world of the colour engineer.

#### A1.2 PHYSIOLOGICAL BASIS

Colour perception results as a neurophysiological response elicited by light entering the eye, or by any other activity producing excitation of the neurons subserving colour vision (like pressing on the eyeball, for example). A particular colour sensation can always be related to a particular output ratio of the three types of photoreceptors (cones) that form part of the neural tissue (retina) that covers the back of our eye. In addition, there is also a fourth, much more sensitive (and actually much more numerous) class of photoreceptors, the rods (so-called because of their cylindrical shape), that are active during night vision. The rods can only signal luminance information, but, at twilight (mesopic vision), the signals of rods and cones can be mixed, resulting in more or less desaturated colours.

The cones, which are only activated at relatively high light levels, can be sub-divided into three

classes, that are roughly tuned, by their different light-sensitive pigments, to the short, middle and long-wave portion of the visible spectrum (the electromagnetic waveband from 380-770 nm). Therefore, they are usually referred to, in modern terminology, as S, M and L cones (cf. Walraven, 1997).

Lights that differ in spectral composition will generally produce different ratios of S, M, and L pigment absorptions, thus enabling the eye to distinguish the difference in colour. However, this does not mean that there is a fixed relation between a multi-spectral light and its associated colour response. The latter is determined by a triplet of cone outputs, but that particular triplet may be generated in many different ways. In fact, the number of possible wavelength combinations that can produce a given colour response is unlimited. This may be intuitively appreciated when realising that each cone type can respond over a wide range of wavelengths that may nevertheless be indistinguishable when appropriately adjusted to produce the same output. So, if a particular colour has the cone signature  $L/M/S = 3/7/2$ , a light of any spectral composition, but producing the same  $2/7/3$  signal ratio, will produce exactly the same colour sensation. This is another way of saying that, to certain degree, the visual system is essentially colour-blind. It is because of this deficiency (the trichromacy of colour vision) that we only need three phosphors for generating a wide gamut of colours on a colour monitor.

#### A1.3 COLOUR SPACE AND COLOUR PERCEPTION

Since colour vision is trivariant, colour can be represented in a three-dimensional space. That can be any space that somehow reflects the way in which a light is registered in the photopigments of the cones. Ideally one might use a space with dimensions directly measuring the S, M and L light catches (because that is the relevant signature of a colour), but unfortunately the (standardised) system generally used is still the 1931 X, Y, Z system of the CIE (Commission Internationale de l'Eclairage). Here X, Y, Z, the so-called

tri-stimulus values, may be conceived of as the light energy absorbed in a set of artificial photoreceptors with spectral absorptance characteristics that are different from those of the cones, but nevertheless traceable to them by linear transformations (e.g. Vos, 1987).

Colour is usually not expressed in the absolute quantities  $X$ ,  $Y$ ,  $Z$  but in relative units, representing the contribution of  $X$ ,  $Y$  and  $Z$ , as proportions of the total light input, that is

$$x = X/(X+Y+Z); y = Y/(X+Y+Z); z = Z/(X+Y+Z)$$

Note that  $x + y + z = 1$ , so there is no need for specifying more than two of these so-called chromaticity coordinates. The convention is to use  $x$  and  $y$ , which thus form the coordinates of the well-known  $x$ ,  $y$  CIE chromaticity diagram (Figure A1.1). Note that since  $x$  and  $y$  only specify *relative* amounts of light, they only relate to the spectral aspect of the stimulus, its *chromaticity*. For a complete specification one also requires an absolute value. The convention is to use  $Y$ , which has the special property that its spectral distribution describes the overall light sensitivity ( $V_\lambda$ ), of the eye. It thus captures the *luminance* of a visual stimulus.

The horseshoe-shaped area shown in Figure A1.1 represents the domain of possible  $x,y$  values. The domain is limited, because the range of differential cone stimulations is restricted. This is a consequence of the fact that it is impossible to

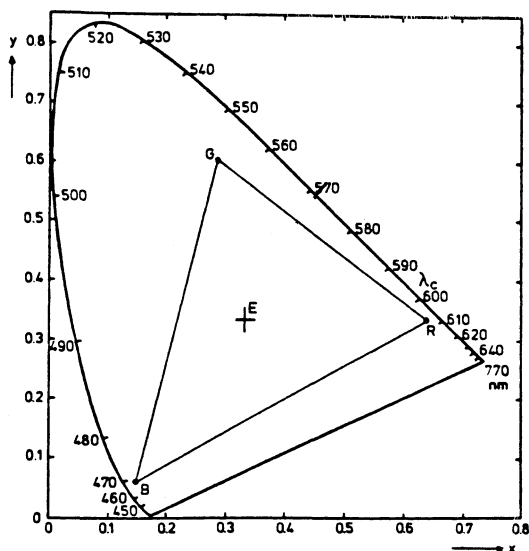

**Figure A1.1: The CIE (1931)  $x,y$  chromaticity diagram. The chromaticities that can be typically generated on a colour CRT are bounded by the triangle of phosphor chromaticities (R,G,B).**

stimulate a single receptor class, whether real (S, M, L) or artificial (X, Y, Z). This means, among other things, that neither  $x$  or  $y$  can take values equal to unity.

Note that the chromaticity domain covered by a colour CRT (the RGB triangle) is still further limited due to the restrictions imposed by the phosphor primaries.

The boundary of colours in the  $x$ ,  $y$  plane is formed by the curved line passing through the adjacent spectral colours (the spectral locus) and the straight line (purple line) connecting the spectral extremes (380 and 770 nm). All chromaticities within that boundary can be made by mixing at least two different colours, located at opposite sites of the chromaticity in question.

The achromatic centre of colour space ( $x=y=0.33$ ) has the chromaticity of an equal energy light (E), that is, light with a flat energy distribution over the whole (visual) spectrum. This is perceived as white, black or an intermediate grey, depending on the luminance contrast with surrounding light.

The farther away colours are located from the achromatic centre, the more vivid (i.e. less pale) they become. This perceptual attribute is called *saturation*. The physical stimulus correlate is referred to as *excitation purity* ( $P_e$ ), that is, the distance relative to point E. The direction of the line connecting a particular colour and the E-point is indicative of its hue (again, a perceptual attribute). The stimulus correlate of hue is called *dominant wavelength* ( $\lambda_d$ ), that is, the wavelength at which the line passing through E, and the colour point in question intersects the spectrum locus or purple line. The hue produced by  $\lambda_d$  is the hue prevailing in all colours located between point E and  $\lambda_d$  (or a certain purple). Such colours are to a certain extent related, differing only in saturation. Table A1.1 summarises the aforementioned the main variables of perceived colour and the corresponding physical stimulus correlates.

**Table A1.1: Perceptual attributes of a colour and it's physical correlates**

Perception	Physical stimulus correlate
colour	chromaticity coordinates ( $x,y$ ) and luminance ( $Y$ )
hue	dominant wavelength ( $\lambda_d$ )
brightness	luminance ( $Y$ )
saturation	excitation purity ( $P_e$ )

Colours at opposite sides of the achromatic centre are called complementary. When mixed in the proper proportions, they cancel each other's hue, thus yielding an achromatic perception. The mechanisms involved in the perceptual outcome of mixing colours are organised in three neural systems (channels), comprising one achromatic and two chromatic channels (e.g. Livingstone & Hubel, 1988). The chromatic ones are "exclusive/or" processors, signalling either redness or greenness (red-green channel), or either blueness or yellowness (blue-yellow channel) depending on the balance of difference signals coming from the photoreceptors from which they receive their inputs (this explains why there is not a bluish-yellow or reddish-green colour, whereas other combinations, like greenish yellow are not excluded). The achromatic channel, which is subserved by all photoreceptor types, comes to the fore when the chromatic channels are in a state of equilibrium, as is the case for a stimulus that produces equal outputs at the receptor level such as an equal energy white or a mixture of two complementary lights. The combined output of the channels provides the input to the perception of brightness.

Since the two (primary) colour sensations produced by a single chromatic channel are mutually exclusive, their perceptual combination is non-existent. We cannot see a reddish green or a bluish yellow. Only sensations subserved by more than one channel combine perceptually, like, for example, yellowish red (orange) or greenish blue (cyan).

Knowledge of the dimensions and structure of perceptual colour space is important for an optimal use of colour in information coding. One can thus represent related task elements or data by related colours, like for example, colours varying only in saturation. Similarly, dissimilarities can be coded by complementary colours. In general, it enables the designer to implement what Hudson (1984) has called "natural mappings between task and display".

#### A1.4 THE COLOUR PALETTE OF A CRT

The colours that can be generated on a CRT display are the result of optical mixing (in the eye) of the red (R), green (G), and blue (B) light emitted by the thousands of tiny triads of phosphor dots, covering the surface of the display. Colours that result from mixing two lights can be located in the

CIE diagram on positions along the line connecting the chromaticities of the lights in question. When a third light is added, all mixtures along the bichromatic mixture trajectory can now form new, trichromatic, mixtures with the added light. The mixture line thus becomes a mixture plane, that is, the triangle connecting the chromaticity loci of the mixture primaries (see Figure A1.1).

There are other representations possible of chromaticity space, representations in which distances between colours are more or less representative for their perceptual "distances" (e.g. Hunt, 1977). This is definitely not the case for the  $x, y$  diagram, as may be intuitively clear when noting that in this diagram the white point is almost equi-distant from yellow (at 575 nm) and blue (475 nm). In reality, the perceptual distance between yellow and white is much smaller than the distance between blue and white. An example of a diagram that provides a better perceptual representation, a so-called *uniform chromaticity scale* (UCS) is the CIE 1976  $u' v'$  diagram, which is shown in Figure A1.2.

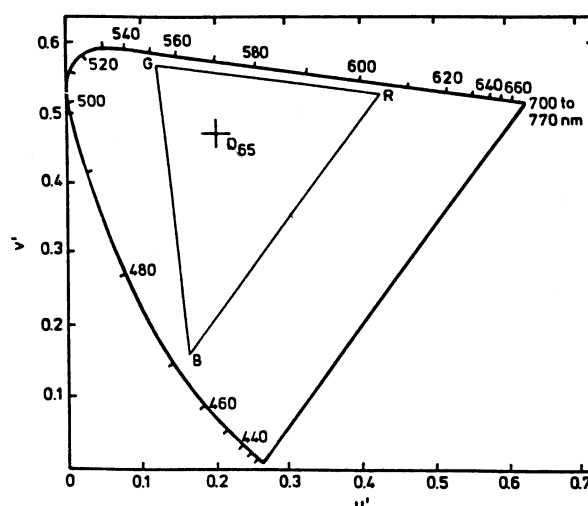
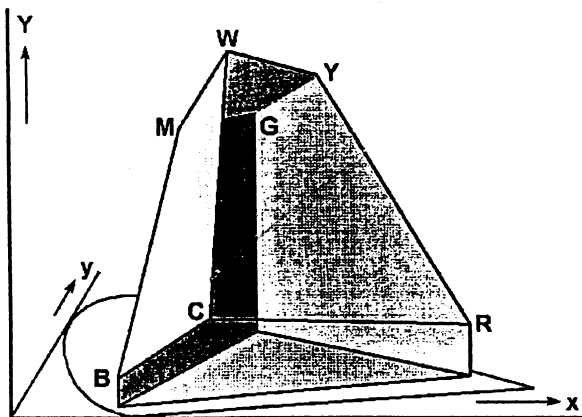

Figure A1.2: The CIE 1976  $u' v'$  diagram with RGB phosphor chromaticities

The  $u' v'$  chromaticity diagram is a useful representation for selecting colours that have to be chosen with certain perceptual criteria in mind. If, for example, one has to select colours that are maximally discriminable, one can do so by maximising the distances between them as measured in the  $u' v'$  plane. However, the  $u' v'$  plane is just a slice through colour space. What is lacking is a third dimension, that is, the luminance of the colours, or rather, an appropriate transformation, so as to yield a perceptually

relevant axis, representing brightness or lightness. (See later for an explanation of these terms). So, what is really needed is a uniform three-space colour metric that is applicable to the colours seen on a CRT. This is not as easy as it seems, because the available standard CIE metrics, CIELUV and CIELAB (cf. Robertson, 1977) were intended for surface or object colours rather than the self-luminous colours seen on a CRT display. An appropriate uniform metric for such called “aperture colours” is still to be developed by the CIE. In the meantime various attempts have been made to derive transformations from UCS spaces that would be better suited for specific display applications, in particular with respect to the legibility of coloured alpha numeric symbols on coloured backgrounds (Lippert, 1986).

A point often overlooked in recommendations for colour use in display design is that the gamut that is available on a CRT display becomes more and more restricted with increasing luminance demand. This is illustrated in Figure A1.3, which shows the three-dimensional envelope (in  $x$ ,  $y$ ,  $Y$  space) of the colours that can be generated on a CRT display.



**Figure A1.3: The colour space covered by a standard CRT display.**

As can be seen by the tapering shape of the CRT's colour space, the available colour gamut becomes smaller at higher luminance levels. The first colours that drop out are the saturated reds and blues, so the display designer may have to consider relatively desaturated colours in order to achieve enough brightness of the colour palette.

## A1.5 SOME BASIC TERMS AND UNITS RELATED TO LIGHT AND VISION

The definitions given in the following glossary are to a large extent identical, or nearly so, to those given in the International Lighting Vocabulary of the CIE (1970). For a complete account of colour science see Wyszecki and Stiles (1982).

In the following only a limited excerpt, most relevant for display engineering, is reproduced, thereby respectively covering the psychological, photometric, colourimetric and physical aspects of light and colour.

### A1.5.1 Perception

#### *Colour*

Aspect of visual perception by which an observer may distinguish between two visual stimuli that differ only in their spectral composition. Colour is three-dimensional, encompassing hue, brightness (or lightness) and saturation.

#### *Hue*

Attribute of perceived colour which has given rise to colour names such as: blue, green, yellow, red, purple, etc. This is the psychosensorial correlate, or nearly so, of the colourimetric quantity “dominant wavelength”.

#### *Brightness*

Attribute of visual sensation according to which an area appears to emit more or less light. This is the psychosensorial correlate, or nearly so, of the photometric quantity “luminance”.

#### *Lightness*

Attribute of visual sensation according to which a body seems to reflect, or reflect diffusely, a greater or smaller fraction of incident light. This is the psychosensorial correlate, or nearly so, of the photometric quantity “luminance factor”.

#### *Saturation*

Attribute of perceived colour which permits a judgement to be made of the proportion of pure chromatic colour in the total sensation. It is the psychosensorial correlate, or nearly so, of the colourimetric quantity “(excitation) purity”.

#### *Unique (primal) colours*

Colours perceived as basic and quite unmixed with any other. Red, green, blue, yellow, black and

white are usually proposed as fundamental in this sense.

#### *Complementary colours (perceived)*

Colours that are felt to be “opposite” or highly contrasting (e.g. blue and yellow). The physiological correlate can be traced to the antagonistic organisation of opponent colour cells in the brain. The colourimetric correlate is indicated by the same term.

#### *Aperture colours*

Colour perceived as not attached to an area or object, such as that perceived as filling a hole in a screen (isolated colour). For example, the red colour of a traffic light is an aperture colour.

#### *Surface (object) colours*

Colour perceived to belong to an area or object in a visual scenery (not isolated). For example the red colour of a cherry is a surface colour.

### **A1.5.2 Colourimetry**

#### *Colour*

Characteristic of visible radiation by which an observer may distinguish between two visual stimuli that differ only in their spectral composition. Psychophysical colour can be specified in three dimensions, usually the standardised tristimulus values of radiation (X, Y, Z).

#### *Tristimulus values (CIE 1931 XYZ System)*

Reference stimuli for describing a colour stimulus (angular subtense between 1° and 4°) obtained by multiplying the colour stimulus function  $\phi(\lambda)$  by the CIE spectral tristimulus values and integrating these products over the whole visible spectrum. (For stimuli with angular subtense greater than 4° the CIE 1964 supplementary  $X_{10}$   $Y_{10}$   $Z_{10}$  system should be applied).

#### *Spectral tristimulus values (colour matching functions)*

Spectral weighting functions  $\bar{x}(\lambda)$ ,  $\bar{y}(\lambda)$ ,  $\bar{z}(\lambda)$  that define the tristimulus values (XYZ) of the spectral components of an equi-energy spectrum.

Note:  $\bar{y}(\lambda)$  is identical with the spectral luminous efficiency function  $V(\lambda)$ .

#### *Chromaticity coordinates (x, y, z)*

Ratio of each of the tristimulus values (X,Y,Z) to their sum (X+Y+Z). Note that  $x + y + z = 1$ .

#### *UCS chromaticity coordinates ( $u'$ , $v'$ )*

Transformations of x and y chromaticity coordinates which define a U(niform)-C(hromaticity)-S(cale) diagram in which the distance between any two colour points is intended to represent a measure of the corresponding difference in perceived colour.

#### *Dominant wavelength ( $\lambda_c$ )*

Wavelength of a monochromatic light stimulus that, when combined in suitable proportions with a specified achromatic light stimulus, yields a match with the colour stimulus considered (symbol  $\lambda_d$ ). When the dominant wavelength cannot be given (this applies to purples) its place is taken by the complementary wavelength.

#### *Excitation purity ( $p_e$ )*

Distance, on the 1931 CIE standard chromaticity diagram, between the achromatic (white) point and the sample point, relative to the distance between achromatic point and the spectrum locus representing the dominant wavelength of the sample.

#### *Primaries*

Any set of (usually) three colours, e.g. red, green and blue, from which a large gamut of colours can be derived by (additive) mixture.

#### *Complementary colours (psychophysical)*

Two colours which, when (additively) mixed, in appropriate proportions, produce a match with a specified achromatic light stimulus.

### **A1.5.3 Photometry**

#### *Spectral luminous efficiency function ( $V_\lambda$ or $V'_\lambda$ )*

Weighting function describing the relative spectral efficiency (of the human eye) for monochromatic light.  $V_\lambda$ , for photopic (cone) vision;  $V'_\lambda$ , for scotopic (rod) vision.

#### *Luminous flux (F)*

Quantity derived from radiant flux by weighting the radiation with  $V(\lambda)$ .

#### *Lumen (lm)*

SI unit of luminous flux, i.e. luminous flux emitted within unit solid angle (one steradian) by a point source have a uniform luminous intensity of one candela.

*Luminous intensity (I)*

Luminous flux leaving the light source, propagated in an elementary cone containing the given direction ( $d\phi$ ), divided by the solid angle of this cone. Unit, candela (cd).

*Candela (cd)*

SI unit of luminous intensity, i.e. the luminous intensity, in the perpendicular direction, of a surface of  $1/600,000$  square meter of a black body (full radiator) at the temperature of freezing platinum under a pressure of 101,325 Pa. Unit, lm/sr.

*Luminance (L)*

Luminous intensity in the given direction of an element of the surface at this point ( $dI$ ), divided by the area of the orthogonal projection of this element on a plan perpendicular to this direction ( $dA \cos \theta$ ). That is, luminous intensity per unit projected area. Unit,  $\text{cd/m}^2$ .

*Luminance factor ( $\beta$ )*

Ratio of the luminance of a surface to that of a perfect reflecting white diffuser, identically illuminated.

*Illuminance (E)*

Density of luminous flux incident on a surface. Unit, lux (lx).

*Lux (lx)*

SI unit of illuminance, i.e. luminous flux of 1 lumen uniformly distributed over a surface of 1 square meter. Unit,  $\text{lm/m}^2$ .

**A1.5.4 Radiation***Photon (quantum)*

Elementary quantity of radiant energy (quantum) whose value is equal to the product of Plack's constant  $h$  and the frequency  $\nu$  of electromagnetic radiation.

*Radiant energy ( $Q_e$ )*

Energy emitted, transferred or received in the form of radiation. Unit, joule (J).

*Radiant flux ( $\phi_e$ )*

Power emitted, transferred or received in the form of radiation. Unit, watt (W).

*Radiant intensity ( $I_e$ )*

Radiant flux propagated in an elementary cone containing the given direction ( $d\phi_e$ ), divided by the solid angle of this cone. Unit, W/sr.

*Radiance ( $L_e$ )*

Radiant intensity in the given direction of an element of the surface at the point ( $dI_e$ ), divided by the area of the orthogonal projection of this element in a plan perpendicular to this direction ( $dA \cos \theta$ ). That is, radiant intensity per unit projected area. Unit,  $\text{W/sr/m}^2$ .

**A1.6 REFERENCES**

1. Benzsawel, T. (1992), Colorimetry of self-luminous displays. In H. Widdell and D.L. Post (Eds.), *Color in electronic displays*, pp 3-39, New York: Plenum Press.
2. CIE (1987), International lighting vocabulary (CIE Publication No. 41), Central Bureau of the CIE, Geneva.
3. Hunt, R.W.G. (1984), The specification of colour appearance - I: Concepts and terms, *Color Research and Application* 2, pp 55-68.
4. Livingstone, M.S. and Hubel, D. (1988), Segregation of form, color, movement and depth: anatomy, physiology and perception, *Science*, 241, pp 740-750.
5. Robertson, A.R. (1977), The CIE 1976 colour difference formulae, *Color Research and Application* 2, pp 7-11.
6. Vos, J.J. (1978), Colorimetric properties of a 2° fundamental observer, *Color Research and Application*, 3, pp 125-128.
7. Walraven, J. (1992), Colour basics for the display designer. In H. Widdell and D.L. Post (Eds.), *Color in electronic displays*, pp 3-39, New York: Plenum Press.
8. Walraven, J. (1997), Recent progress in colour vision, (*Report TNO TM-97-A051*) Soestrebeg, The Netherlands; TNO Human Factors Research Institute.
9. Wyszecki, G. and Stiles, W.S. (1982), *Color Science* (2nd ed.), John Wiley and Sons, New York.

## Appendix 2

### Common Colour Vision Testing, Apparatus and Manuals

J. Terry Yates and Jean-Pierre Menu

#### A2.1 TESTING PROCEDURES

##### A2.1.1 General Considerations

1. The examination room may have an influence on test results. Coloured curtains, coloured wallpaper, etc. may intrude. A neutral environment is preferred. In Germany, for example, neutral daylight is stipulated in the German standard DIN 5033.
2. The physiological and psychological state of the person being tested is important. A well-rested, relaxed examinee is preferred and efforts should be made to insure that this is the case.
3. The state of light adaptation should be insured. Daylight adaptation conditions without exposure to extreme brightness levels should be achieved. Adaptation prior to testing in a colour-free room is desirable. Focal illumination of the retina such as occurs during ophthalmoscopy should be avoided just prior to testing.
4. The lighting conditions for each test must be observed. Both brightness and colour balance (colour temperature) must be correct. Generally arrangement tests and plate tests require illuminant C (a colour temperature of 6774 degrees Kelvin). The Macbeth Easel lamp is preferred source of illuminant C (when available) or a suitable substitute is the True Daylight Illuminator with a Veralux lamp. (Richardson Optical, Boca Raton, Florida).
5. Test distance for each test is specified in the manual and will be discussed for each test.
6. Appropriate spectacle correction is mandatory. Recognition of test numerals, for example, requires good acuity. And, of course, testing of a cycloplegic examinee is useless. All test norms presume the correct light intensity, a normal pupil and a specified test distance.

#### A2.2 INSTRUCTION MANUALS (ABRIDGED)

##### A2.2.1 Dvorine Pseudo-isochromatic Plates (See Figure A2.1)

###### A. Physical Arrangements

1. There are fifteen plates in a set; one demonstration plate (sometimes called the teaching plate or the malingerers plate) and fourteen test plates.
2. The Macbeth Easel lamp or True Daylight Illuminator is required. All other sources of illumination should be eliminated.
3. The examinee's line of sight should be at right angles to the test plates at a distance of 20 to 30 inches.
4. Testing is monocular. The uninvolved eye should be suitably patched.

###### B. Administration

1. Instructions: "Please read the numbers". The examiner shall not give other instructions or ask any other questions. The examinee is not permitted to trace the numbers or patterns or to touch the test plates.
2. The demonstration plate is shown first. All of the other plates are then shown one at a time.
3. A response time of no more than five seconds per plate is permitted. Should the examinee hesitate, the examiner asks again "read the number". In the event of no response, the examiner moves on to the next plate.
4. With the exception of the demonstration plate which is always first, the order of the plates should be rearranged often.

###### C. Scoring

1. Ten or more correct responses on the fourteen test plates correctly identified is a "colour NORMAL" condition and should

be entered in the examinee's records. If five or more incorrect responses are given the record entry should read "colour DEFECTIVE". The demonstration plate is not used in scoring.

2. An identification of one number of a two-digit plate is a failure of the entire plate. No response when asked to identify a plate number constitutes a failure of that plate.
3. Interpretation of error scores is only valid when the proper conditions of

illumination, test distance and timing of presentation are correct.

#### D. Purpose

"This test of red-green deficiency is for **screening** purposes".

**NOTE:** The instructions, administration and scoring of the American Optical and Ishihara pseudo-isochromatic plates (not illustrated) are essentially identical to the description provided for the Dvorine instrument.

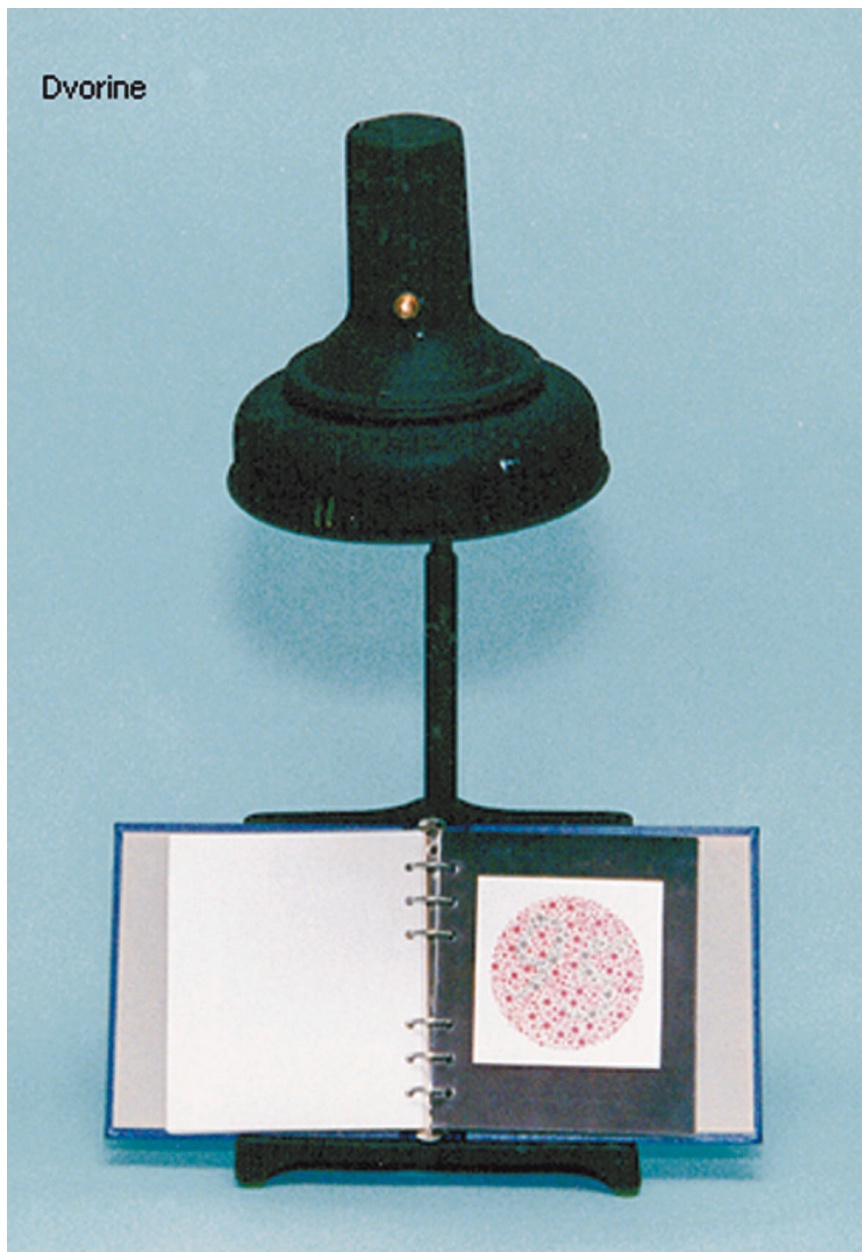

Figure A2.1: Dvorine Pseudo-isochromatic Plates for screening of red-green colour defects



### A2.2.2 The City University Colour Vision Test (See Figure A2.2)

This test was an attempt to utilise the test colours from the Farnsworth Panel D-15 test in a plate format. Unfortunately it has been evaluated by the National Research Council Working Group 41 as not suitable for screening in the general population. A better choice is the Farnsworth Panel D-15 test.

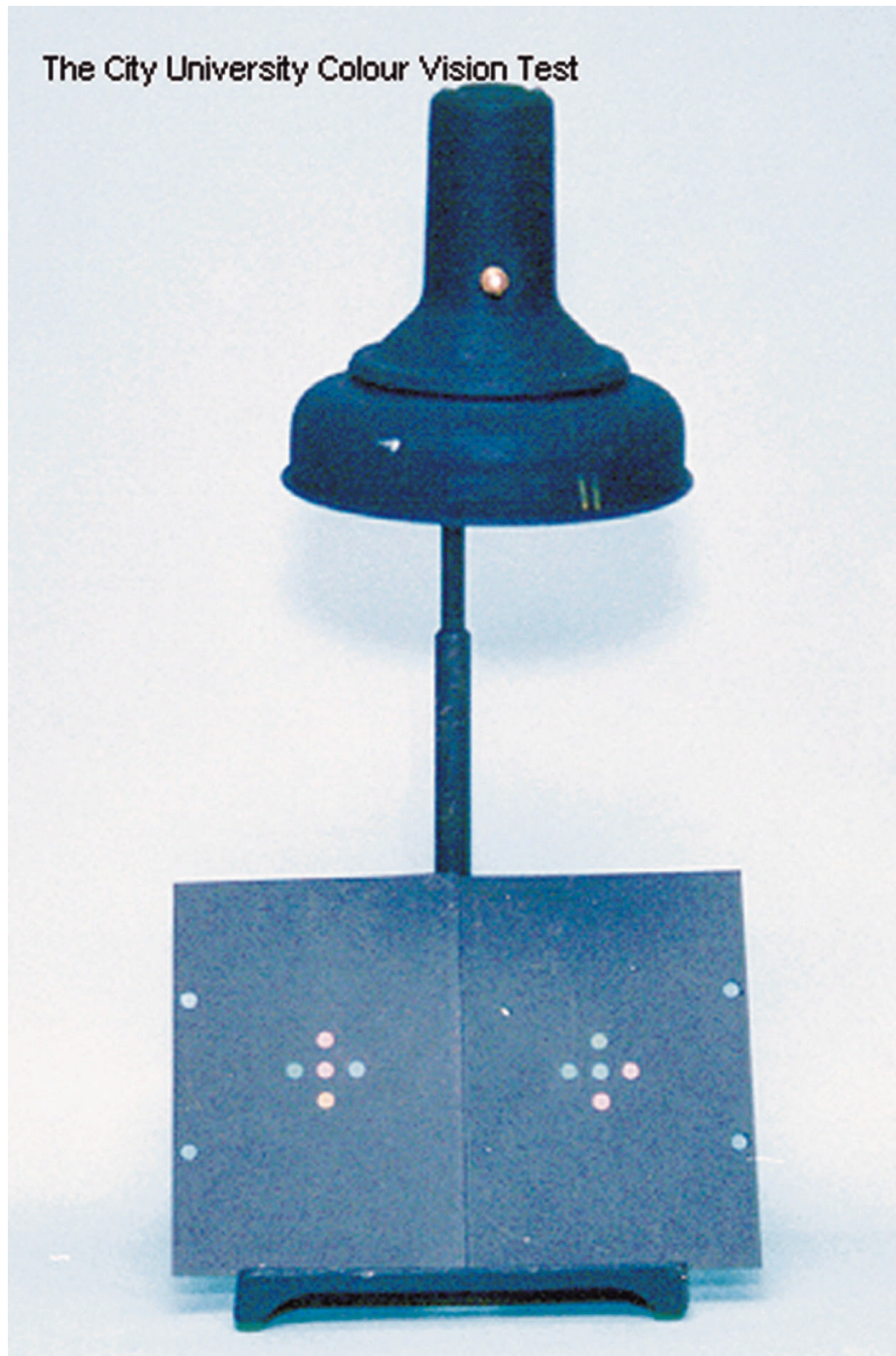

Figure A2.2: The City University Colour Vision Test

### A2.2.3 Standard Pseudo-isochromatic Plates II (SPPII) (See Figure A2.3)

This example was included to demonstrate a new plate test methodology thought to be useful in screening for acquired blue-yellow deficits. Validation data indicated great promise.

Unfortunately, the test is no longer in print and only serves to indicate the frustration possible when attempting to find commercial instruments that are easy to administer, inexpensive and that are valid and reliable.

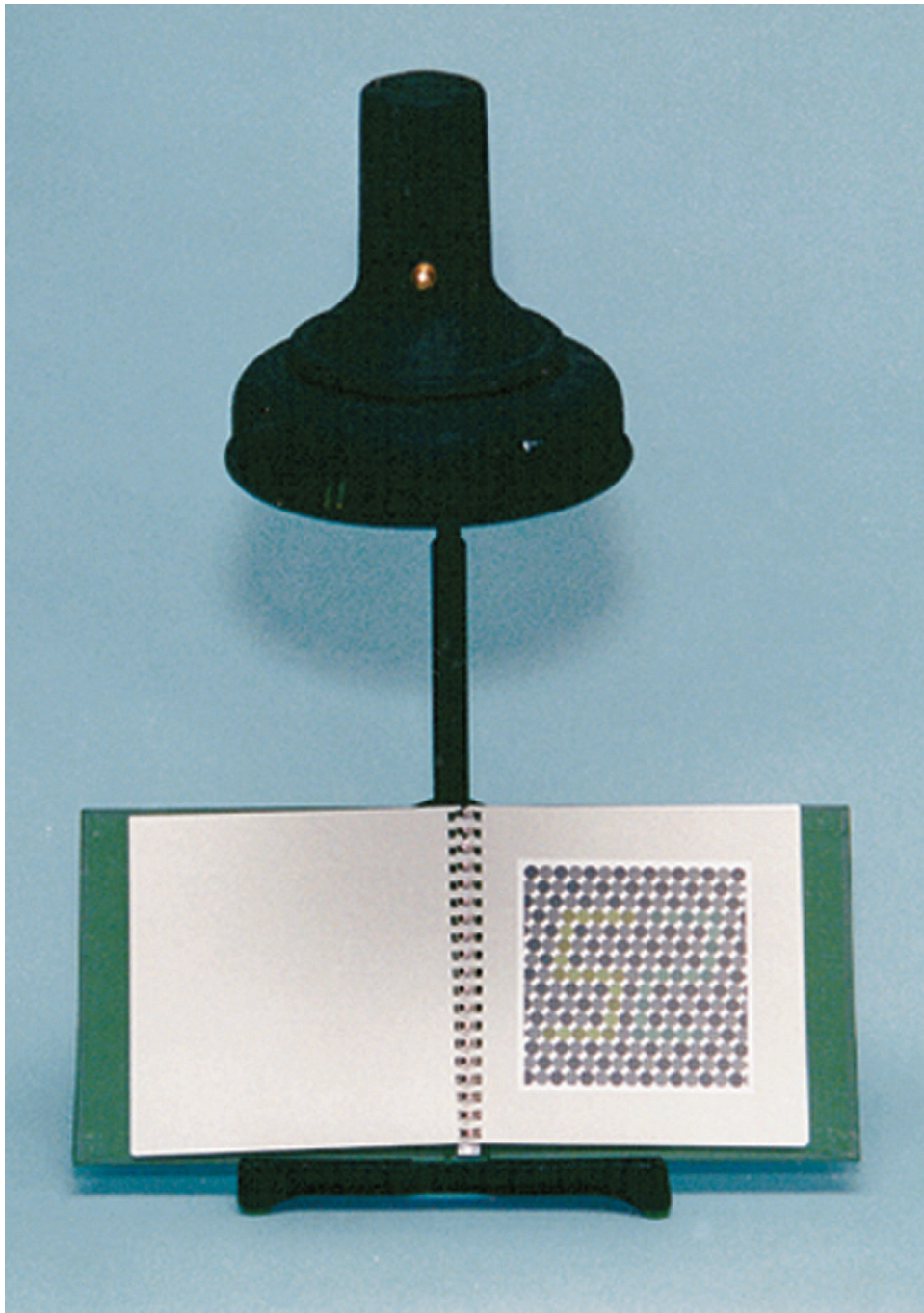

Figure A2.3: The Standard Pseudo-isochromatic Plates for evaluation of acquired blue-yellow defects.

### A2.2.4 The Farnsworth Dichotomous Test for Colour Blindness (Panel D-15) (See Figure A2.4 and A2.5)

#### Materials

Consists of a rack, colour caps and scoring sheets. There are fifteen coloured caps with pigments on their upper surface and numerals on the bottom. The caps usually reside in the wooden rack. A reference cap is permanently affixed at one end of the bottom of the rack. The caps should not be exposed to light for long times and the coloured part of the cap should not be touched by fingers or the caps will be damaged. (Solution – have examinee use white cotton photographic gloves).

#### Administration

1. Lighting is illuminant C.
  2. The test is administered individually to each evaluatee one eye at a time. The caps are removed from the bottom of the rack and placed **randomly** in a row in the top of the rack.
  3. The evaluatee is instructed: **“The object of the test is to arrange the buttons in order according to colour. Take the button from this panel (indicate) which looks most like that and place it here (indicated space next to the fixed reference cap). Take the button which looks most like that, and place it here; and the button most like that place it here. Continue doing this until all the buttons are arranged in order.”**
  4. Young children and the mentally challenged will need special attention. If the examinee doesn't grasp the concept, repeat the instructions. After each button, it may be necessary to say, **“Now, which of these buttons (indicate) is most like the last one (indicate).”**
  5. To prevent dawdling, it is suggested that the evaluatee be told that the time permitted is two minutes. However, the examinee should not be held to the time limit. Evaluatees who have rushed through the test or not taken it seriously should be asked to review it and make changes to get the caps “all in order”.
2. Beginning with the reference cap, the numbers are recorded on the scoring sheet in the order in which they were placed by the examinee. The caps are returned to the other half of the case in random order, ready for the next test.
  3. Consequential errors will be immediately obvious. If errors are noted, a pattern should be drawn on the diagram provided on the score sheet. A straight edge is used to connect the points on the diagram in the order in which they were recorded beginning with the point labelled “Reference Cap”.

#### Interpretation

1. The test is scored on a pass or fail basis. A circular pattern indicates a passing profile, while parallel lacing indicates failing.
2. Two kinds of profile will likely be seen. Normal and colour weak examinees will follow the circle. Local inversions are reversals of caps that do not cross the circle. Crossings indicate that caps from the opposite side of the circle have been interposed with the normal sequential pattern. Colour weak individuals may have local inversions and/or one crossing. Colour blind individuals will show a series of parallel crossings in approximately the same direction. The scoring sheet shows axes labelled “protan”, “deutan”, and “tritan”. The type of deficiency is indicated by crossings that most closely parallel the labelled axis. In interpreting the type of problem, more weight should be given to those crossings that most closely parallel one of the labelled axes.
3. A single crossing is usually the result of carelessness and a retest should be given.
4. It should be noted that pseudo-isochromatic plate type tests pick out the eight to nine percent of the male population that are not normal. This test picks out the four to six percent whose colour deficiency is so severe that they might be expected to cause inefficiency in ordinary occupations.

#### Scoring

1. The cover is closed over the caps and the case is turned over and opened to show the scoring numbers on the bottom.

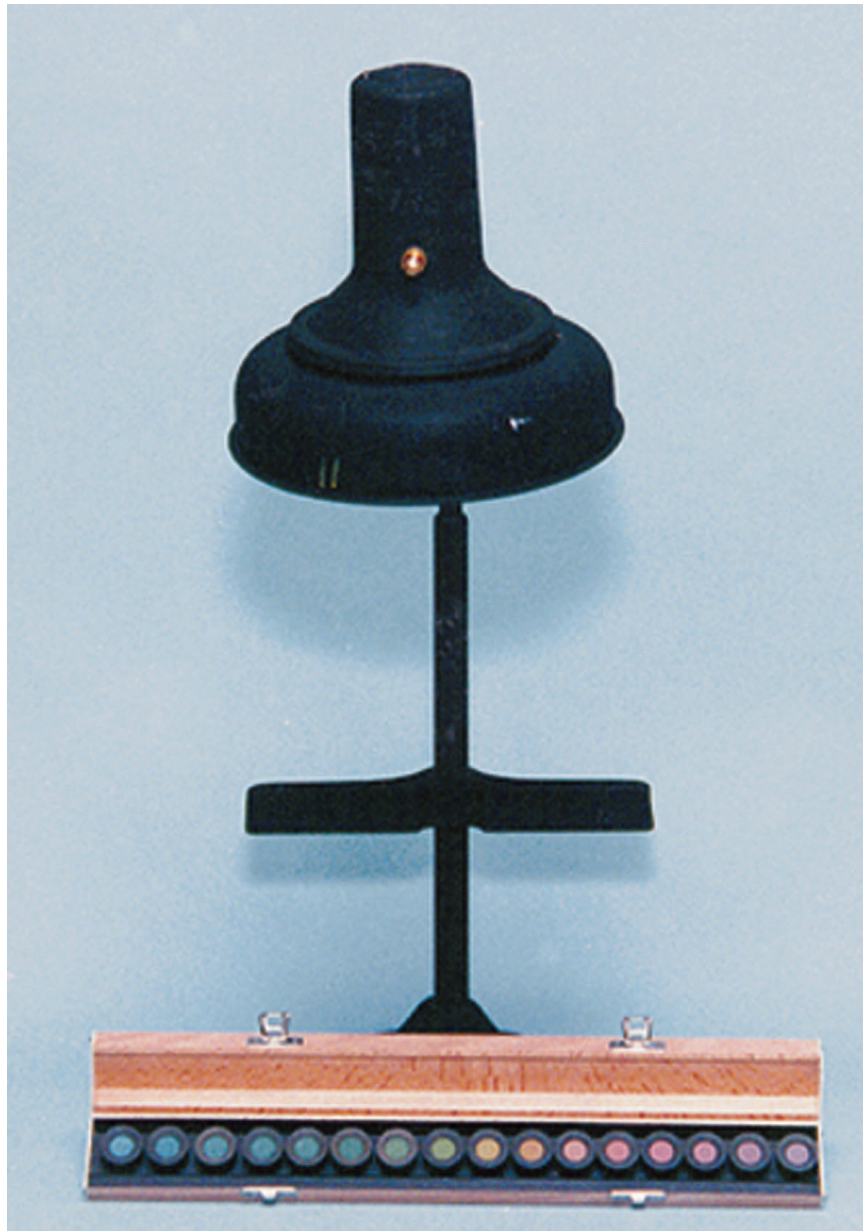
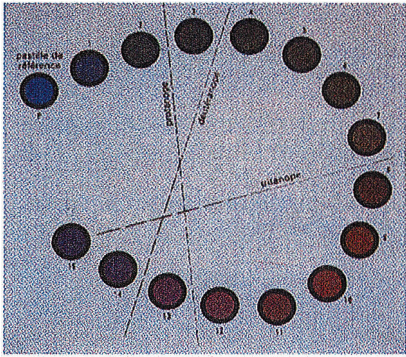
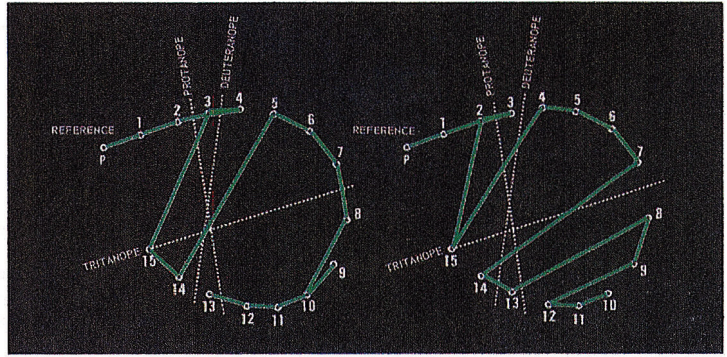

Figure A2.4: The Farnsworth Dichotomous Test (Panel D-15) for Dichromacy



**A : FARNSWORTH 15 Hue**



**B : Use of the diagram**

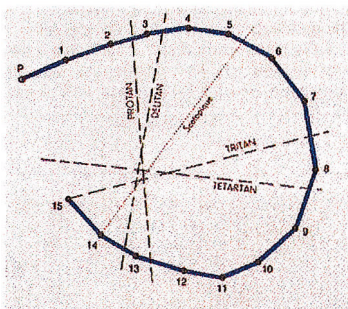

**C :  
DYSCHROMATOPSIA  
Red – green axis**

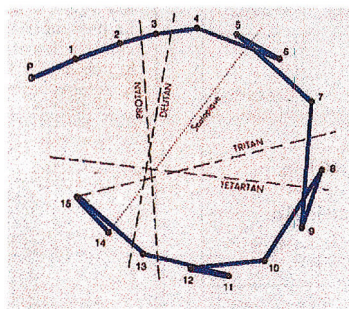

**D :  
DYSCHROMATOPSIA  
Red – green axis**

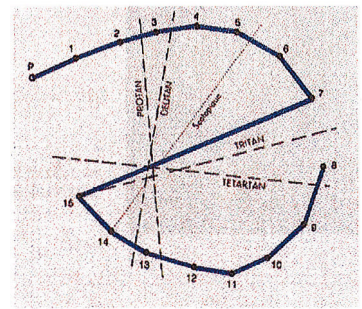

**E :  
DYSCHROMATOPSIA  
Blue – yellow axis**

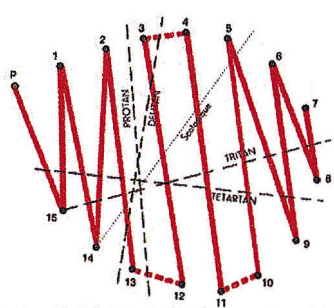

**F :  
PROTAN : Red blind**

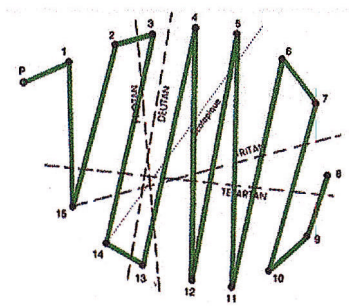

**G :  
DEUTAN : Green blind**

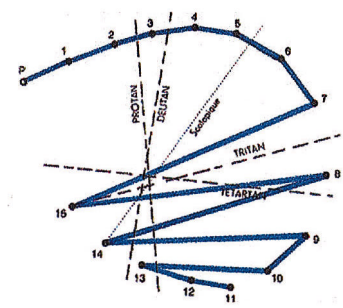

**H :  
TRITAN : Blue blind**

Figure 2: Panel D15 Plot

Figure A2.5: A variety of dichromacies are shown with varying severity. Both red-green and blue-yellow defects are evident.

### A2.2.5 Rodenstock Colour Vision Test (See Figure A2.6)

#### Materials

1. A special disk with glass colour filters is inserted into an existing vision testing apparatus. The disk contains twelve pairs of hues.
2. An upper and lower semicircular test field is witnessed by the evaluatee.

#### Administration

1. Testing is binocular with the apparatus set for "binocular distance test". If diplopia is present and can not be overcome, the test is given monocularly. Spectacle correction should be worn. Mild spectacle tint is acceptable, but not deep tints.
2. A preliminary examination is accomplished first. The evaluatee is told that there are two

possible responses: "same" or "different". That is, the colour of the upper test field matches or does not match the lower test field. This procedure is accomplished with the disk positions numbered 1-6. The first run is not scored and serves as a familiarisation trial.

3. A second run utilises the remaining disk positions labelled 1'-6' and serves as the formal testing procedure. A special scoring sheet is provided and the evaluatee's responses are recorded.

#### Scoring and Interpretation

Protanomalous, deuteranomalous observers as well as protanopes, and deuteranopes may be identified by means of the scoring sheet. The test is described as a course selection device and an anomaloscope exam is recommended in those cases that cannot be decisively classified.

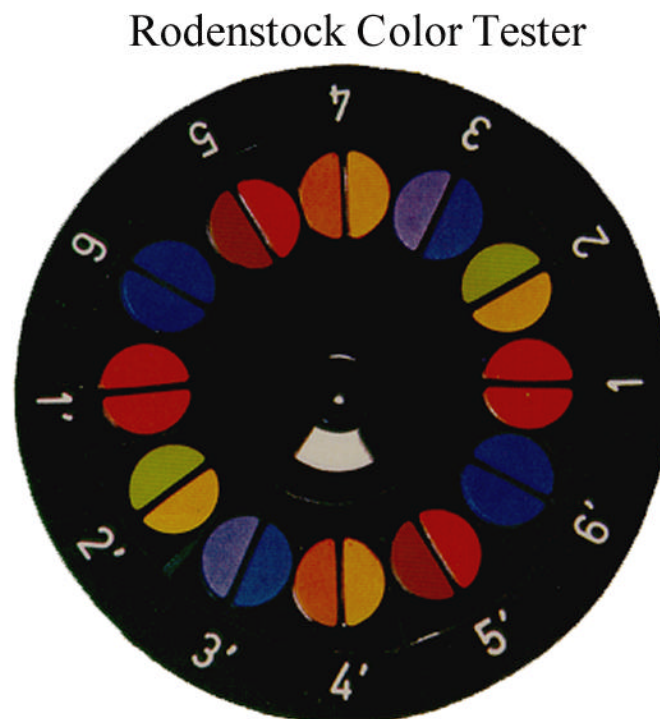

Figure A2.6: Rodenstock Colour Tester

### A2.2.6 Lanthony's Desaturated 15 Hue Test according to Farnsworth–Munsell (See Figure A2.7)

#### Materials

1. Consists of a rack, colour caps and scoring sheets. There are fifteen coloured caps with pigments on their upper surface and numerals on the bottom. The caps usually reside in the wooden rack. A reference cap is permanently affixed at one end of the bottom of the rack. The caps should not be exposed to light for long times and the coloured part of the cap should not be touched by fingers or the caps will be damaged (Solution – have examinee use white cotton photographic gloves). The hue of the chips is much less obvious than the standard test since they have been desaturated. For observers with modest colour deficiencies or borderline colour blindness and who may pass the standard test, the discrimination between chips becomes impossible with this instrument. Therefore, it detects anomalous trichromacy as well as dichromacy.
2. The test shares many properties with the panel D-15 test after which it was modelled. Interpretation is not the same however (see below).

#### Administration

1. Lighting is illuminant C.
2. The test is administered individually to each evaluatee one eye at a time. The caps are removed from the bottom of the rack and placed **randomly** in a row in the top of the rack.
3. The evaluatee is instructed: **“The object of the test is to arrange the buttons in order according to colour. Take the button from this panel (indicate) which looks most like that and place it here (indicate space next to the fixed reference cap). Take the button which looks most like that, and place it here; and the button most like that and place it here. Continue doing this until all the buttons are arranged in order.”**
4. Young children and the mentally challenged will need special attention. If the examinee doesn't grasp the concept, repeat the instructions. After each button, it may be necessary to say, **“Now, which of these**

**buttons (indicate) is most like the last one (indicate).”**

5. To prevent dawdling, it is suggested that the evaluatee be told that the time permitted is two minutes. However, the examinee should not be held to the time limit. Evaluatees who have rushed through the test or not taken it seriously should be asked to review it and make changes to get the caps “all in order”.

#### Scoring

1. The cover is closed over the caps and the case is turned over and opened to show the scoring numbers on the bottom.
2. Beginning with the reference cap, the numbers are recorded on the scoring sheet in the order in which they were placed by the examinee. The caps are returned to the other half of the case in random order, ready for the next test.
3. Consequential errors will be immediately obvious. If errors are noted, a pattern should be drawn on the diagram provided on the score sheet. A straight edge is used to connect the points on the diagram in the order in which they were recorded beginning with the point labelled “Reference Cap”.

#### Interpretation

A moderately comprehensive atlas is provided with the test with examples of a variety of clinical entities demonstrated and with comparison of those results with the standard test. The reader is referred to that work for greater understanding. It should be noted that this test is not as well validated as the Panel D-15 and caution should be used in interpretation.

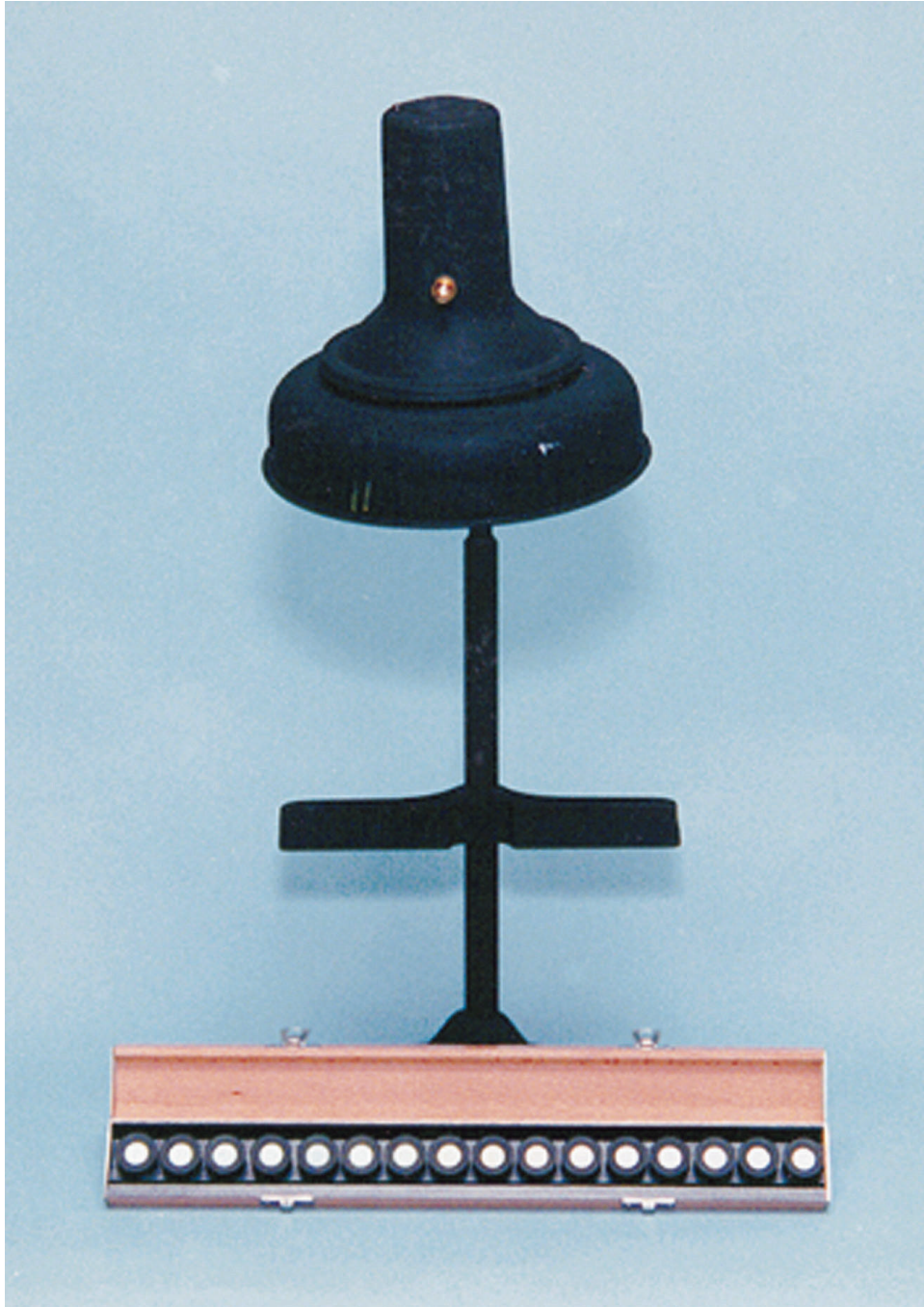

**Figure A2.7: Lanthony's Desaturated 15 Hue Test according to Farnsworth-Munsell. Those individuals with mild dichromacy as seen on the standard D-15 test will present with more errors on this more difficult version of the test. Desaturation makes hue discrimination more difficult.**



### A2.2.7 Farnsworth Lantern (FALANT) (See Figure A2.8)

#### Materials and Administration

1. The lantern is a self-contained unit in a steel case. It is a kind of slide projector. Since it is self-contained, room lights may be left on. The test screen should be screened from glare and sunlight excluded. The evaluatee should not face the source of room light.
2. Only one person may be tested at a time.
3. Station the evaluatee eight feet from the lantern.
4. Instruct examinee: **“The lights you will see in this lantern are either red, green or white. They look like signal lights at a distance. Two lights are presented at a time in any combination. Call out the colours as soon as you see them, naming first the colour at the top and then the colour at the bottom. Remember, only three colours, red, green and white – and top first.”**
5. Turn the knob at the top of the lantern to change the lights. Depress the button in the centre of the knob to expose the lights. Maintain regular timing of about two seconds per exposure.
6. Expose the lights in random order starting with an RG (red, green) or GR (green, red)

combination (numbers one or five), continuing until each of the nine combinations has been exposed.

#### Scoring

1. If no errors are made on the first run of nine pairs of lights, the evaluatee is passed.
2. If any errors are made on the first run, discard the results of the first run and give two more complete runs.
3. Average the errors of these last two runs. If the evaluatee has an average of more than one error per run, he is failed. If the evaluatee has an average of one error, or less than one error per run, he is passed.
4. An error is considered the miscalling of one, or both, of a pair of lights. If an evaluatee changes his response before the next light is presented, record his second response only.
5. If the evaluatee ordinarily uses glasses for distance, he should wear them.
6. If an evaluatee says “yellow”, “pink”, etc., remind him, **“There are only three colours – red, green and white.”**
7. If an evaluatee takes a long time to respond, tell him, **“As soon as you see the lights, call them.”**



**Figure A2.8: The Farnsworth Lantern is a screening tool for red-green colour defects. It is a rather liberal test, but has the advantage of not requiring special lighting conditions since the illuminator is contained in the apparatus.**

### A2.2.8 Lanthony New Colour Test (See Figure A2.9)

#### Materials

1. The test was designed specifically for use in acquired colour vision defects. It permits determination of those colours that are confused with grey (neutral zones) and tests chromatic discrimination at four levels of saturation.
2. The test comes in four boxes of fifteen coloured caps. The hues are the same in each box but differ in saturation including a high saturation, two medium saturation and a low saturation box. In addition there are ten grey caps of varying lightness.

#### Administration

1. The test is performed in two phases called separation and classification. Separation involves mixing the ten grey caps with the high saturation caps from the first hue box. The evaluatee must sort the caps into two groups; a group that appears grey and another that appears to have colour.
2. In the classification phase the evaluatee orders the grey caps ranging from dark to bright. Second the evaluatee orders the coloured caps in their natural order. There is no fixed starting cap as in the Farnsworth Panel D-15.
3. The procedure is repeated for the other three boxes.

#### Scoring

1. Scoring the separation phase is accomplished on a circular diagram. Compartments on the diagram are pencilled in to indicate which coloured caps were confused with grey caps. In this fashion neutral zones are identified on a colour circle.
2. In the classification phase, a second scoring sheet is used. For each coloured cap wrongly placed among the greys, a circle is drawn at its position on the grey scale on a special form of traditional graph paper with hue on the abscissa and value on the ordinate. The order of the coloured caps is recorded on another specialised scoring sheet that resembles the one used for D-15 scoring. It has a separate ring for each of the four saturations. The order of the coloured caps is indicated in the same fashion as for a D-15 with the added complexity of the four levels.

#### Interpretation

1. The separation test gives three sorts of useful information.
  - a) Location of the neutral area. The location of the neutral area in hereditary deficiencies is well known and “stereotyped”. In acquired deficits, its location is more variable and the ability to locate it is thought to be an advantage of the test.
  - b) Width (angular size) of the neutral area. If the neutral area is wide, it is most characteristic of pathology, especially if it occurs in regions of high saturation. The location plus width serve to characterise the colour system involved and the severity of the defect.
  - c) Thickness is described by the number of divisions along a radius of a given hue. It represents the linkage to the saturation parameter. The thickness is greatest along the axis of dyschromatopsia.
2. The classification of greys permits an understanding of those colours that are perceived as grey. Normal ordering would result in just grey caps being judged as grey. The intrusion of coloured caps into that order indicates pathology and the precise colours provide another piece of evidence concerning the nature of the defect.
3. The classification of colours serves to delineate colour confusion in the same fashion as the Panel D-15 test, but in more detail.

Three sorts of composites may result from this test:

- 1) Normal trichromatism with no neutral area, and no colour confusion.
- 2) Abnormal trichromatism with no neutral area, but with colour confusion.
- 3) Dichromatism with a neutral area and colour confusion.

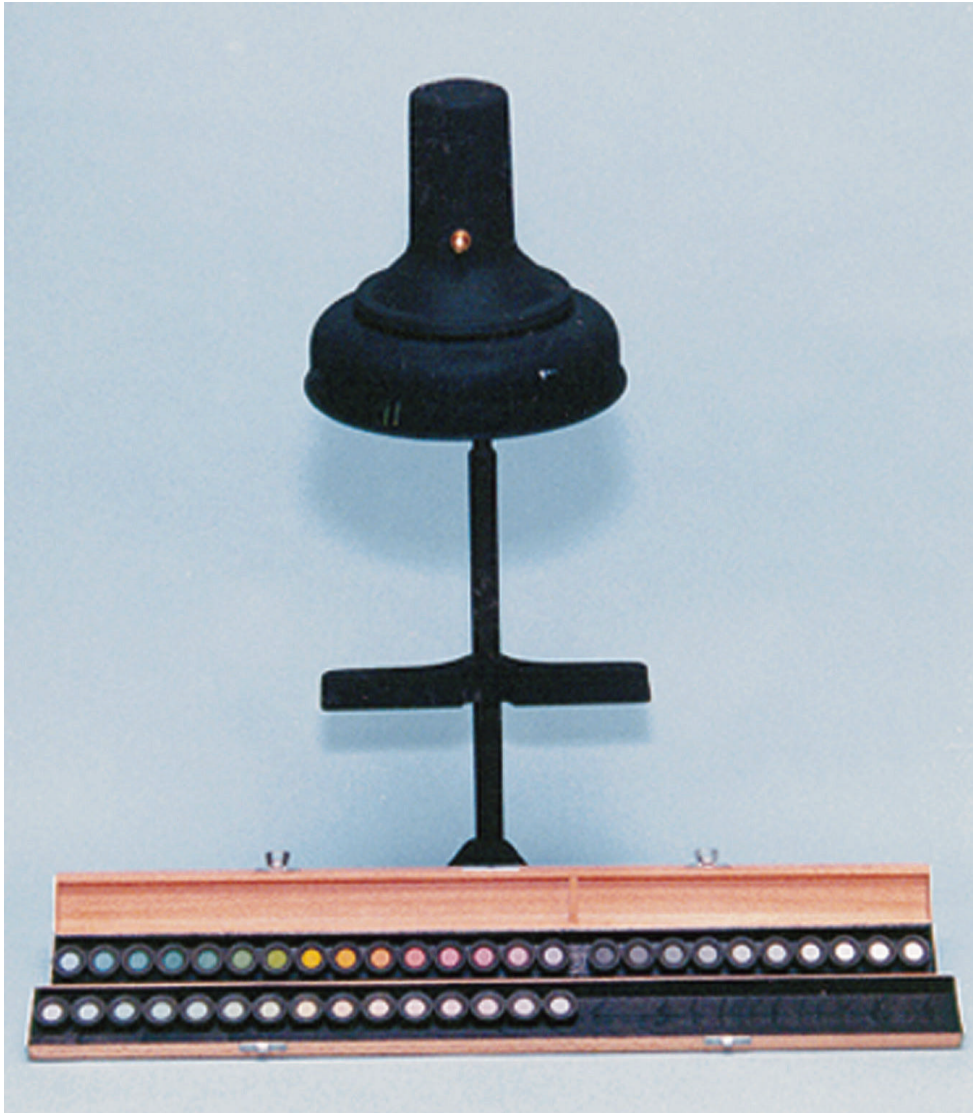

**Figure A2.9: Lanthony New Colour Test.** This rather new test was designed to characterise chromatic discrimination and to locate neutral points that are not discriminated from hues by colour defectives. It is particularly useful when characterising acquired colour defects. Standardisation has been most extensive with that population.

### **A2.2.9 AQT-6 Colour Vision Tester (See Figure A2.10)**

#### **Materials**

1. The AQT-6 is a self-contained unit with light emitting diodes producing that mimic the colours in an anomaloscope. It determines a subject's ability to discriminate red-green mixtures from yellow or blue-yellow mixtures from white. It is of use in dealing with both hereditary and acquired colour vision deficiencies.
2. The unit is lightweight and portable. Calibration does not change with time increasing the reliability of the instrument.

#### **Administration**

1. Minimal operator training is involved. A hand-held remote control determines the test format.
2. Average test duration is one to two minutes.
3. There are five test colours for the red-green test and six test colours for the blue-yellow test.
4. Test stimuli are presented four at a time. On any presentation, one colour will be different than the other three. The locus of the non-matching colour must be identified.
5. The stimulus is presented for a fixed duration of two seconds.

**Scoring**

1. Scoring is accomplished on special sheets provided with the instrument. The procedure is sequential and leads to a diagnosis.
2. Red-green results are indicated as mild, moderate or severe.

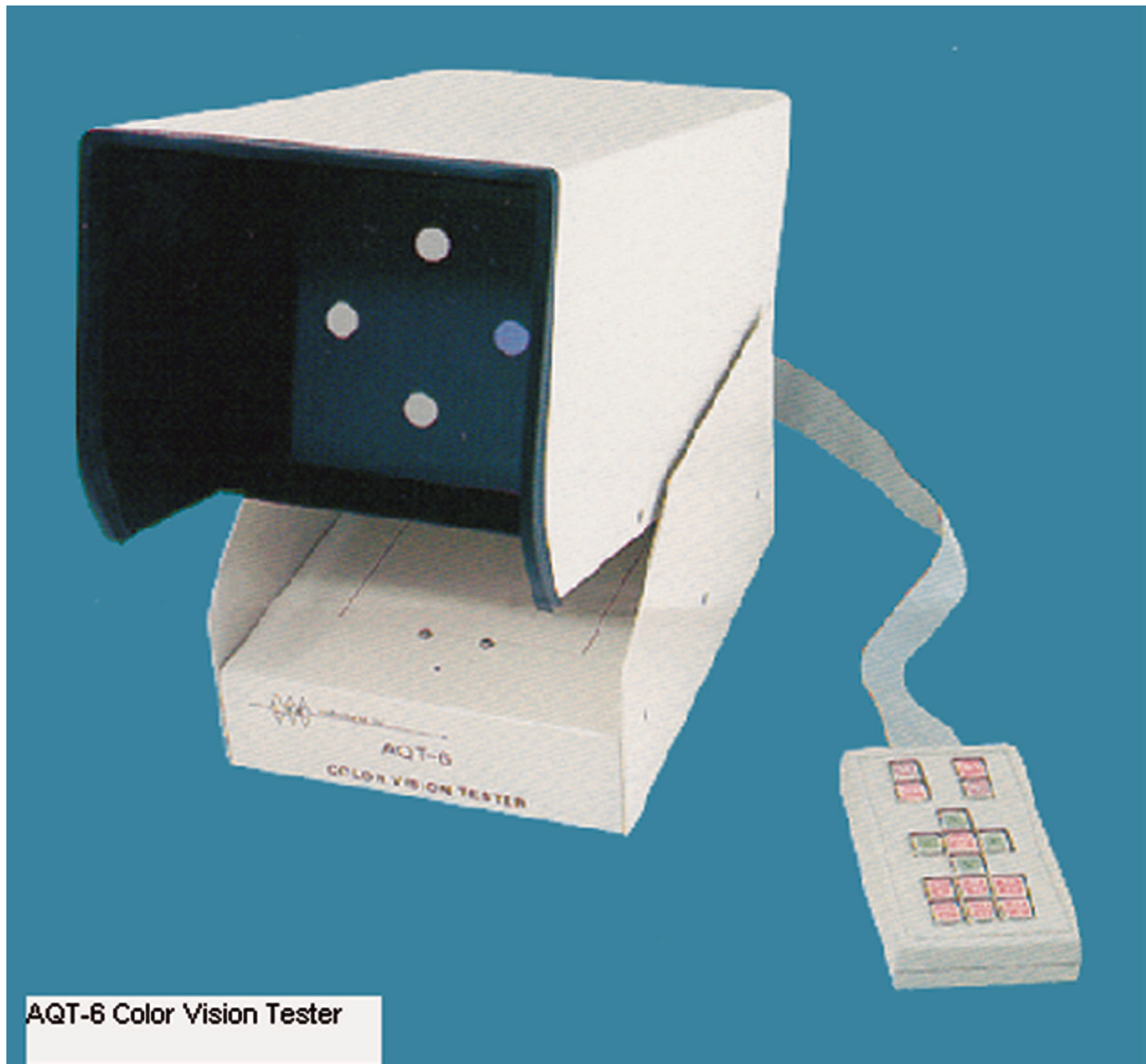

**Figure A2.10: The AQT-6 colour vision tester is based on the Rayleigh principal and shares some properties with red-green anomaloscopes. The device is a convenient screening tool that may be used both with adults and children.**

### A2.2.10 Nagel Anomaloscope (See Figure A2.11)

#### Materials

1. The Nagel Model I is a spectroscopic device designed to evaluate the Rayleigh equation. It presents a circular split field viewed through a telescope-like device. The upper half field is a spectral yellow-green (545 nm) and spectral red (670 nm). The luminance of the pure yellow lower half field may be adjusted from dark to bright. The “red-green” field’s ratio of red and green may be adjusted from all red to all green with any proportion of the two mixed in between.
2. Normal observers will choose an equal amount of red and green for the top half field to produce metametric yellow that matches the lower field. Some observers will also wish to adjust the yellow half field’s luminance to produce an exact match.

#### Administration

1. Measurement requires a trained and experienced examiner. The instrument is adjusted by means of two knobs on the sides of the front of the device for a normal match (yellow = 15 and red-green = 40). The examination starts with a three-minute adaptation period where the evaluatee looks at the built-in Trendelenburg screen on the front panel of the instrument.
2. The adaptation light is extinguished and the evaluatee is asked to describe the appearance of the colours seen in the instrument. The normal observer and the dichromat will say the colours appear to be the same. The protanomalous observer will say that the mixture field appears green and the deuteranomalous observer will say red.
3. If the normal match is accepted, the range of acceptable matches is then evaluated. For normals that range will be small and usually no more than five scale units. The examiner changes the red-green ratio in small increments around the match point asking each time “Is this a match”. The evaluatee is asked to adjust the knob controlling the luminance of the test field. In this fashion, the match centre and matching range are determined and recorded.
4. Dichromats will accept a wide range of red-green mixtures as a “match”. The procedure is

to move the red-green knob to one extreme (0-green) and determine if the observer accepts the match. Similarly the knob is set to the other extreme (73-red) and the match acceptability is determined. The evaluatee is asked to adjust the yellow field in each case. Protanopes have a brightness loss and will set the yellow knob to high numbers at the green end and low numbers at the red end. It is important for the evaluatee to re-adapt to the Trendelenburg screen between each trial. The procedure continues starting at one end of the mixture scale and continuing in increments of ten until the full range of possible matches is evaluated.

5. The extreme anomalous trichromat will show brightness matches like those of a dichromat.
6. Failure to accept a match within the normal range identifies an anomalous trichromat. Based on the initial description of the colour appearance of the mixture field, the red-green mixture field is set in the appropriate direction and the process of finding the match midpoint and range proceeds as in number three above.

#### Scoring and Interpretation

The match midpoint and the range are adequate for delineating the nature of the deficit in anomalous observers. The calibration provided with the machine indicates that:

- a) Deuteranomalous observers make matches in the range of 12-31.
- b) Normal observers make matches in the range of 35-46.
- c) Protanomalous observers make matches in the range of 49-66.
- d) Dichromats accept a wide range of matches spanning nearly all of the mixture field’s range. Protanopes are likely to require large changes in the luminance of the yellow field to achieve a “match”.

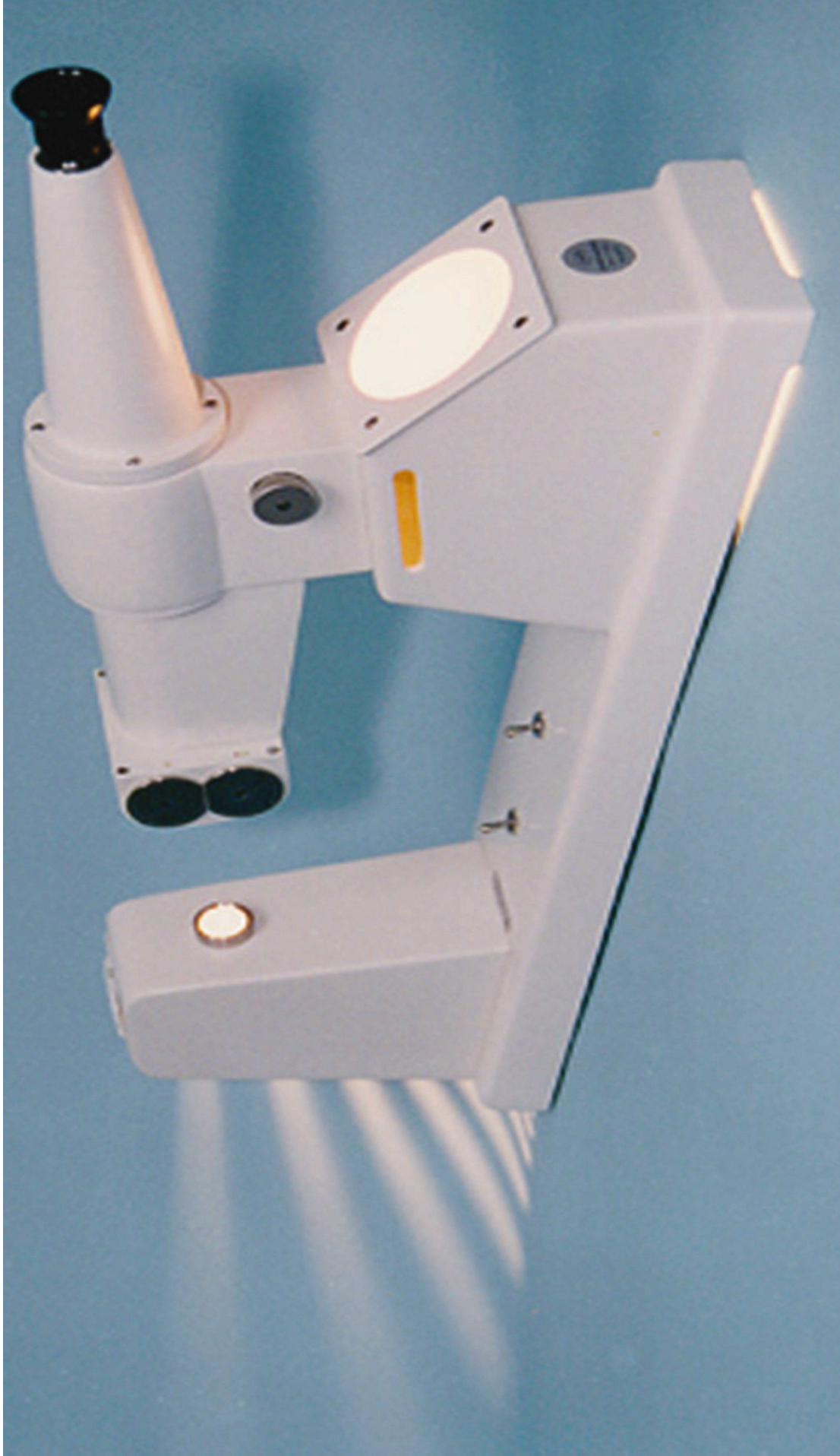

Figure A2.11: Shows the conventional implementation of the Nagel anomaloscope. The device is expensive and somewhat delicate. It is, however, one of the standards against which other colour vision tests are evaluated.

### **A2.2.11 Moreland Anomaloscope** (See Figure A2.12)

1. The only commercial implementation of the Moreland equation is contained within the Spectrum Colour Vision Meter from Interzeag of Schlieren Switzerland. The device is computerised and also contains a Rayleigh match device not unlike the Nagel anomaloscope.
  2. The Moreland equation requires matching a blue-green stimulus made from a mixture of 436 nm and 490 nm lights vs. an unsaturated light of 480 nm. The stimuli are presented in “free view” through a viewing tube with a suitable background. The narrow band primaries are two degrees in extent and are in pairs in a bipartite field (split circle). Viewing is monocular and correction lenses may be inserted into the viewing tube.
- shown in graphical form with comparison information available for normals.
2. A plot of the psychophysical function derived from the test is displayed with the mean for normals and normal limits indicated. If the response is aberrant, the direction of the error is clear.
  3. The match midpoint is printed as well as the matching range. The anomalous quotient is also plotted. Scale units are from zero to one hundred with the normal match midpoint at 50.0. A graphic is provided to demonstrate the match midpoint and the matching range with a boundary of normal limits indicated.
  4. Data may be archived and the individual luminance-versue-colour information reused if advisable.

#### **Administration**

1. Measurement begins in one of two ways. The operator may choose to accept a luminance-versus-colour curve stored in the computer that is derived from a standardisation group or an individual curve may be determined. A demonstration of the procedure is used to familiarise the patient with the process.
2. The second portion of the exam involves two stages. A demonstration program familiarises the patient with the testing process and then the test begins. First, a course psychophysical function is derived by showing pairs of stimuli and having the patient indicate whether the left (comparison) side is more green, equal or more blue than the right hand (standard) side. Nine presentations are used to determine a rough estimate of the match midpoint. A second testing session follows that includes seventeen presentations in the range of the rough match midpoint previously determined. The result is a finer resolution estimate of the match midpoint and matching range. Two additional fine scans may be added for increased resolution of the two previously measured parameters.

#### **Scoring and Interpretation**

1. A variety of information is provided upon test completion. First, if the individual luminance-versue-colour plot has been utilised, it is



**Figure A2.12:** This system contains both a Nagel and Moreland type anamalgam microscope with computer control. Results from the device compare well with the conventional Nagel system. At this writing, it was the only system that included a Moreland equation.



## A2.2.12 Farnsworth–Munsell 100 Hue Test (See Figure A2.13)

### Materials

Materials include ninety-three caps in four wooden cases. Each case has two hinged panels which enclose one-fourth of the eighty-five removable coloured caps. (Two caps are repeated and fixed at each end of the cases making a total of ninety-three caps). Pigments in the caps are made from very stable materials, However they should not be unduly exposed to light or to fingerprints. Slight soiling does not interfere with the test results. Severe soil will contaminate test results and individual caps may be purchased to replace them (as with the D-15, cotton photographic gloves worn by the examinee are recommended to avoid the problem). Score sheets are provided that contain four rows of numbers corresponding to the numbers on the back of the caps in the four cases, a scoring diagram, and spaces for recording demographic data.

### Administration

Lighting is illuminant C. The most convenient position for the administration of the test is across the table from the evaluatee. The light should be from above so that the angle of illumination is about ninety degrees and the angle of viewing is about sixty degrees. The Macbeth Easel lamp or the True Daylight Illuminator (see elsewhere in this document) are suitable light sources.

### Procedure

1. Arrange the caps in random order before testing begins. Open one case lengthwise before the examinee so that the empty inclined panel to which the pilot caps are fixed is nearer the evaluatee. The cases may be given in any order.
2. Instruct the evaluatee as follows:

**“The object of the test is to arrange the caps in order according to colour. Please transfer them from this panel (indicate) and place them so they form a regular colour series between these two caps (indicate). It should take you about two minutes per panel. However, accuracy is more important than speed - so you will be told when the two minutes are up but the panel will not be taken away from you. Arrange them as best you can, but don’t dawdle. Do you understand? Begin”.**

If the evaluatee does not show comprehension, say,

**“Take the button which looks most like that (indicate a pilot button) and place it there.... and the button most like that (indicate the last one) and place it there and so on”.**

### Time

1. Allow evaluatee as long as necessary for him to arrange the buttons in an order with which he is happy. If two minutes have passed and he isn’t through, quietly remind him that two minutes are up, and let him finish his task.
2. For each panel, record the time spent on it and whether it was the first panel, second, etc., given. This information might be useful in interpreting results.

### Recording Data

1. Space is allowed on each data sheet for recording two trials, a test and retest. Where the numbers are found to be in correct order, draw a line above the printed numbers. When they are incorrect, record the order used by the evaluatee.
2. After the arrangement of the caps has been recorded, transfer them to the opposite panel, rearranging them in random order. Then close the case and turn it over. The recessed design of the caps was selected to facilitate this procedure.

### Scoring and Drawing the Pattern

1. If only a few transpositions have occurred, the errors can easily be counted and the pattern does not need to be drawn. Count four for each two-cap transposition and eight for each three cap transposition. If there are many errors it will be necessary to draw a pattern consisting of the scores for each cap. The score for a cap is the sum of the differences between the number of that cap and the numbers of the caps adjacent to it.
2. The inner circle of numbers on the chart corresponds to the number of the caps. Take the first (inside) dotted line as score two (the lowest possible). Mark the score for each cap on the radial line carrying its number. Connect the points by lines of different colours for each test.

3. The total error score is obtained by summing the errors on each radial line, now counting the inner circle as zero. This has the effect of subtracting two from each individual score so that a perfect sequence would sum to zero.

### Retests

The number of retests required is entirely dependent upon the degree of exactness desired. It is merely necessary to ascertain that an examinee has no gross colour deficiency, and one test shows that, there is no point in testing him again. In general, it may be stated that retests should be given when the evaluatee is inexperienced in handling test materials or when a more precise diagnosis is needed or when the pattern is in any way unclear or atypical.

### Interpretation

#### *Average Discrimination*

About sixty-eight percent of the population (exclusive of colour defectives) make a total error score of between twenty and one hundred on first tests. This may be taken as the range of normal competence for colour discrimination.

#### *Superior Discrimination*

About sixteen percent of the population (exclusive of colour defectives) have been found to make total error scores of more than one hundred. The first retest may show improvement, but further retests do not materially affect the score. Repeated retests reveal no region of large maximum or minimum sensitivity as is found in colour defective patterns.

Error scores by normals often exceed those of many colour defectives, yet these individuals do not exhibit other colour-blind indications such as seen on pseudo-isochromatic plates or anomaloscope.

The test is a test of colour aptitude or the ability to make colour discriminations. Colour normals may have good or poor colour discrimination. Colour defectives may have good or poor colour discrimination.

#### *Defective Colour Vision*

Colour defectiveness is exhibited by a bipolar pattern of results; a clustering of maximum errors in two regions that are nearly opposite. The regions

of the errors may be used to determine the type of colour defect involved:

- **Protans** (red blind; protanopes and protanomalous) have a mid point between sixty-two and seventy.
- **Deutans** (green blind; deuteranopes and deuteranomalous) have a mid point between fifty-six and sixty-one.
- **Tritans** (blue blind; tritanopes and tritanomalous) have a mid point between forty-six and fifty-two.

The terms "colour defectiveness" and "colour blindness" have been employed in the literature to indicate a type of systematic colour imbalance, that is to say, certain series of colours are less well discriminated than other series of colours. Pseudo-isochromatic tests are designed to test colour imbalance, but not to test colour discrimination. The 100-hue pattern will indicate the type of imbalance, the colour zones of best and poorest perception and the degree of colour discrimination in those zones as compared to normals.

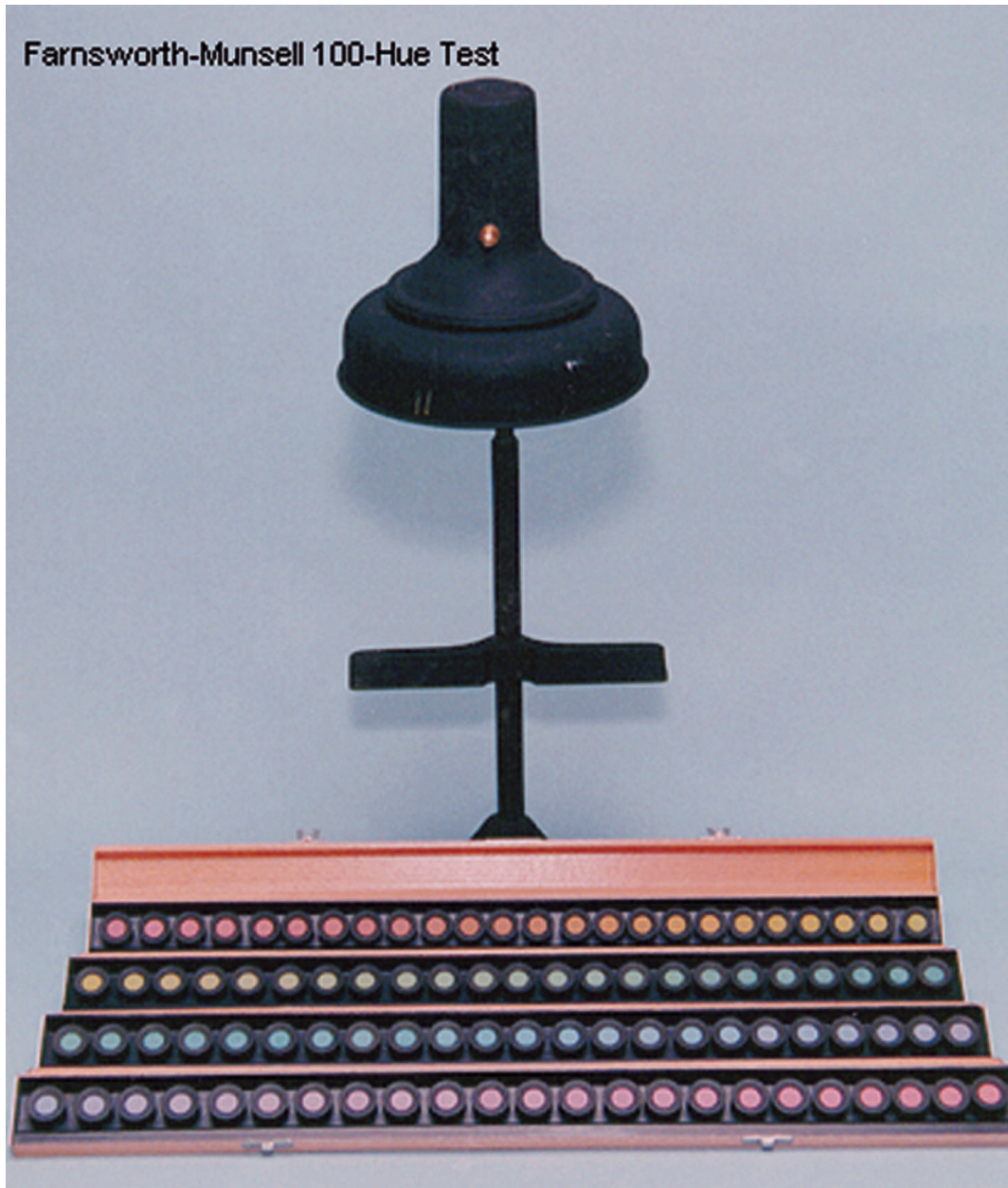

Figure A2.13: The Farnsworth-Munsell 100 Hue Test is illustrated.  
The current configuration contains 85 coloured “caps”.

### FM-100 Polar Plot (See Figure A2.14)

The bipolar plot is characteristic of a deuteranope. A few random errors are also evident. The error

scores are in the mild to moderate range, but the strong bipolarity clearly identifies the hereditary nature of the defect.

21-NOV-94  
RIGHT EYE  
ERROR SCORE = 140

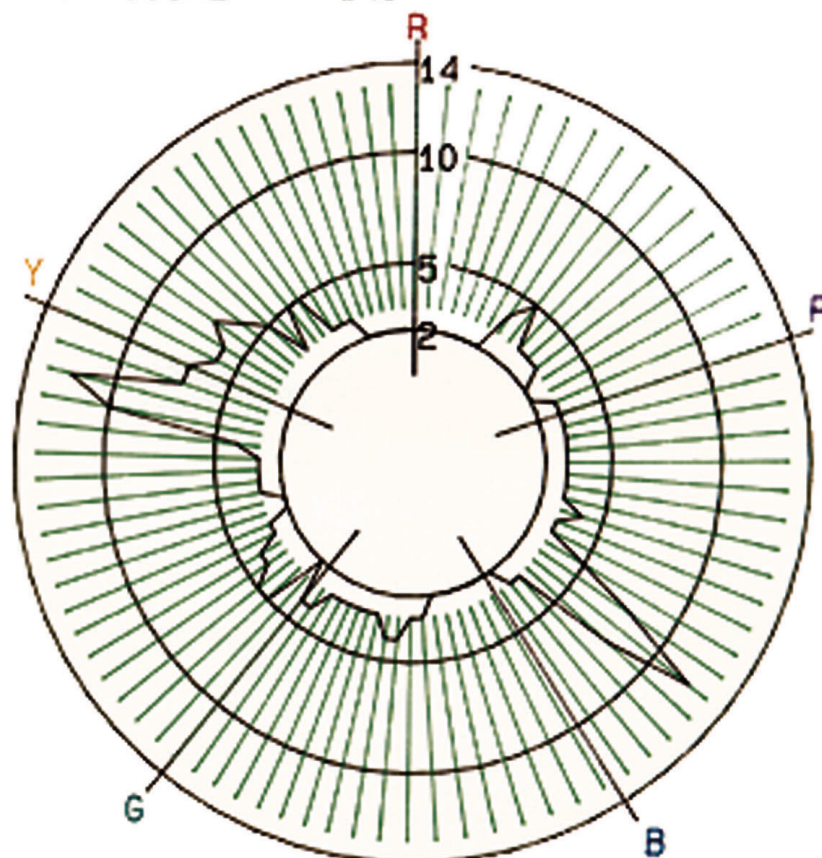

Figure A2.14: A polar plot of data typical of a deuteranope is presented. The clear axis is characteristic of an hereditary defect. Acquired defects tend to be blue-yellow with axes that are less well defined.

### A2.2.13 PROCOPAT Software

#### Ergonomic Test of Colour Sense for Pilots

##### 1. Aims of the test

As we saw previously, colour vision is essential for the correct control of a flight in a modern aircraft. It is the conditions governing the stimulation of colour vision which have changed. Such modifications must be accompanied by new ways of evaluating colour sense. The test should enable *in situ* assessment of the abilities of a subject in whom a fairly important colour vision deficiency has been detected by means of the normal examinations. This is all the more essential in

aeronautics, for pilots whose colour sense will alter during their career; in these cases we talk about revised aptitude rather than initial aptitude. This test is therefore designed to assess **the adaptation of an individual to a job** (piloting with the aid of colour screens) and not a totally isolated visual function (colour vision). It is **a global test, which includes apprenticeship and specific knowledge of a task in addition to colour vision.**

##### 2. Equipment used

The resulting system is obviously more complex than Beynes chromoptometric lamp. It comprises a screen and a synthetic image generator driven by special image creation software.

For reasons of cost, distribution and for purely technical reasons, the use of a real aeronautical tube on board an aircraft was rapidly discarded as an option.

A very high-quality commercial cathode ray tube had to be used to enable faithful reproduction of the colours created by the on-board monitors.

The cathode ray tube is the computer screen used for image generation.

### 3. The different stages of the test

This test is composed of three separate stages. Two of these stages use present-day expertise; these are the stages of colour denomination and of confusion between colours.

#### a) *Colour Denomination*

The colours displayed in aircraft were recorded and a set of simple colour denomination tests were designed.

The images consist of a square of a certain size in the centre of the screen. The rest of the screen is white; the luminance of this surround is therefore masked, which sensitises the test (tone contrast only).

The subject first learns the palette of colours (Figure A2.15), and then indicates the name of the colour. Responses are given directly to the system by designating the name of the colour on a "response table", while following a test image displayed for a given time.

In addition to the characteristics of the colours (colourimetric and luminance coordinates) two variables were taken into account:

- the size of the coloured surface to be recognised ( $4^\circ$  and  $1^\circ$  angle),
- the display time (1 sec or 400 milliseconds).

The quality of the response of the subject is recorded and analysed. The results of this test are used to guide the choice of colours to be displayed in the second stage.

#### b) *Confusion between Colours*

##### *The Maze*

Two basic colours are used. They define fairly large and fairly luminous image regions or surfaces. A pathway must be found along the colour indicated at the start. A limited time

(1 minute) constitutes a temporal constraint on the performance of this test.

The assumption made in this test is that the difficulty in recognising the limits between colours increases as luminosity decreases. The choice of the two colours of course depends on the results obtained during the denomination test. The pathway is followed using the mouse. Subjects are familiarised with operation of the mouse before the start of the test (Figures A2.16a and A2.16b).

##### *The Network*

The thickness of the lines introduces an additional difficulty. Otherwise, the basic principle is the same as that for the previous test. Two colours of different tones and variable luminosities are used. During a given time (1 minute), the subject has to find the shortest path between the starting point and a given finishing point. We know that colour discrimination is poorer when relatively fine lines are used. Following a network of relatively fine lines may prove impossible for subjects with colour vision anomalies (Figure A2.17).

#### c) *Confusion of Aeronautical Images*

This concerns the highest level of complexity of images displayed. It is also the most ergonomic level as the images are a direct copy of the flight and navigation instruments encountered in aircraft such as the Airbus A320. This allows for the subjects experience to be taken into account.

The subject is required to nominate the colours proposed. For example, the bars in the ILS system (instrument landing system) are not always seen as white. The different colours of the weather radar are not necessarily recognised (differences between magenta and brown).

The images are however static and a really ergonomic test would need a procedure for animating and managing the different parameters. Nevertheless, we are quite close to the design and use of a simulator, which means that the philosophy behind colour sense evaluation tests is gradually changing and the approach is becoming more complex.

The different images presented to the subjects are given in Figure A2.18.

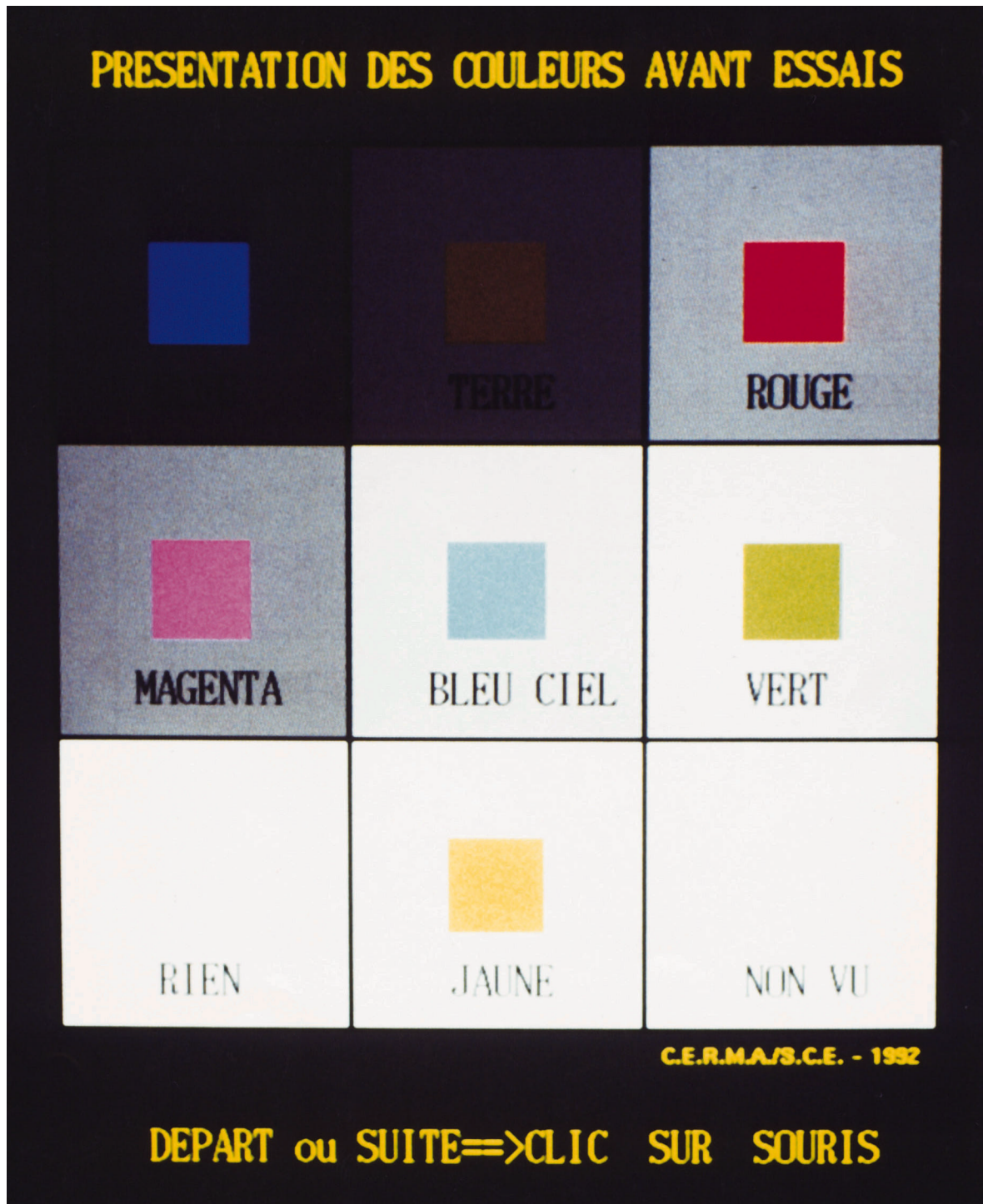

Figure A2.15: Colour Denomination Stage – brown, blue, magenta, red, cyan, green, white.

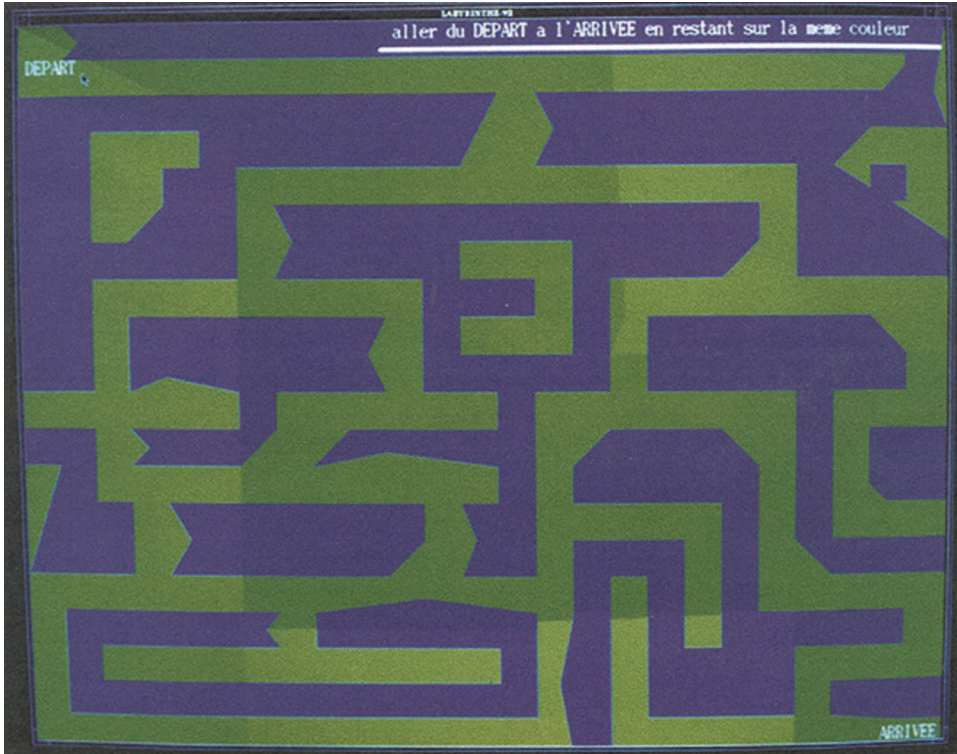

Figure A2.16a: The Maze (green-blue)

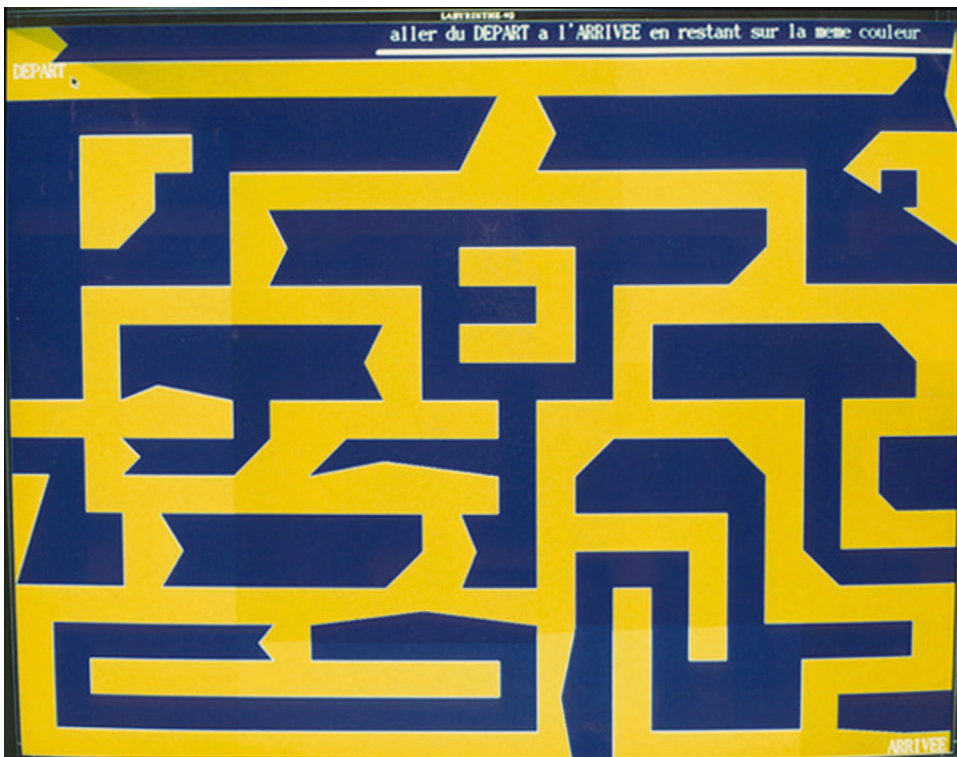

Figure A2.16b: The Maze (yellow-blue)

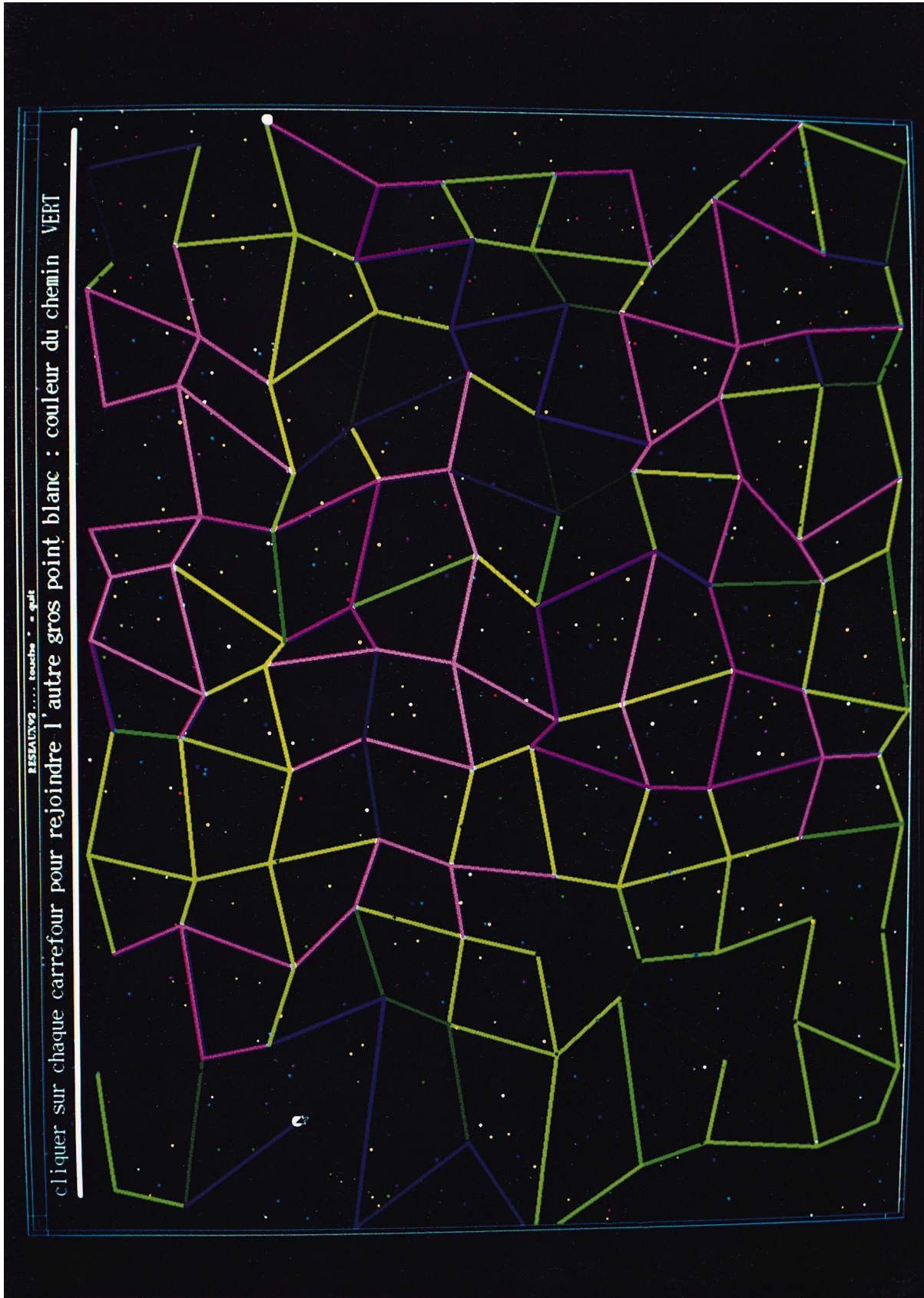

Figure A2.17: The Network



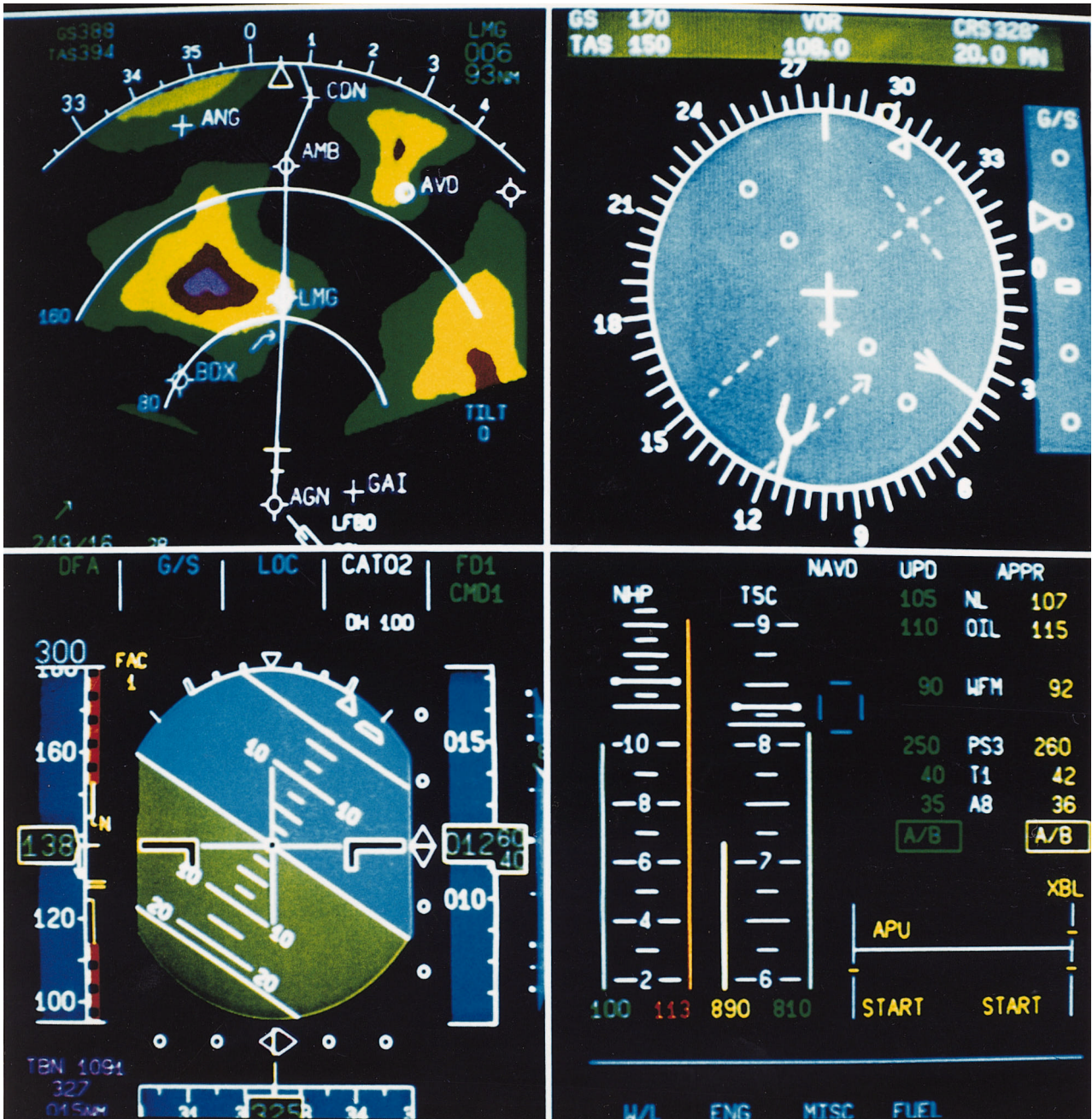

Figure A2.18: Aeronautical Images

**This page has been deliberately left blank**



**Page intentionnellement blanche**

## Appendix 3

### General Glossary

**Anomalous trichromacy** – normal individuals may match any spectral wavelength with a mixture of “red”, “green”, and “blue” light intensities (the wavelength does not change). Anomalous observers require greater intensity of one of the lights to make a match.

**Bezold-Brueke hue shift** – a change in hue as a function of brightness due to adaptive changes within the colour vision system. At low intensities, “blue-green”, “green” and “yellow-green” appear “greener” than they do at high intensities. At high intensities they appear more “blue”. Similarly low intensity, “reds” and “oranges” seem more “red” and at high intensities they seem more “yellow”.

**Depolarisation** – a characteristic of neural cell activation. When transmembrane potentials are measured, a positive voltage response is termed depolarisation. Photoreceptors depolarise in the absence of light. Other end organs depolarise when activated by a stimulus such as touch or sound.

**Deuteranomalous** – an anomalous observer who requires more “green” light from three primaries to match a middle wavelength (“green”) test light than a normal. These observers are not truly colour blind. They are “green” weak.

**Dichromat** – an observer who matches any spectral colour with just two primaries. These individuals are colour blind. That is, there are many hues that they see as colourless (“black”, “white” or a shade of “grey”).

**Homeotherm** – a “warm-blooded” animal. An organism with sophisticated regulatory mechanisms that maintain body temperature at a constant level, largely independent of environmental temperatures.

**Hue discrimination** – the ability to discriminate a hue from other hues. When stimuli are all the same brightness, the minimal change in hue of one stimulus with respect to a reference hue may be evaluated. The discrimination will be due to hue differences and independent of brightness. At the spectral extremes (deep “red” or deep “blue”) discrimination is poor. That is, large changes in wavelength are needed to be perceived as a change

in hue. For other spectral regions much smaller changes will result in a perception of a hue change.

**Hyperpolarisation** – a characteristic of neural cell activation. When transmembrane potentials are measured, a negative voltage response is termed hyperpolarisation. Photoreceptors hyperpolarise in the presence of light. This is the inverse activation pattern seen in other end organs.

**Isoconfusion lines** – a special measurement space has been derived for chromaticity. For dichromats, there are lines plotted in that space that describe colours that are confused. A separate set of confusion lines has been identified for protanopes, deuteranopes and tritanopes.

**Lateral geniculate nucleus** – the relay nucleus for the visual system (See relay nucleus).

**Metamer** – mixture of lights of differing wavelengths that match a spectral hue. For example: 535 nm (“green”) and 670 nm (“red”) when mixed will match a light of 589 nm (“yellow”). Brightness must be equal for the two stimuli. The condition is called metamerism and the stimuli are called metamers.

**Photopic luminosity** – under daylight conditions, the human eye is differentially sensitive to spectral wavelengths. Maximum sensitivity is at 555 nm and is reduced in various amounts for longer or shorter wavelengths. A standard sensitivity function has been specified for a “typical” observer called  $V_\lambda$ .

**Poikilotherm** – a “cold-blooded” animal. An organism whose body temperature is that of the environment. Temperature control is accomplished by moving to a cooler or warmer location.

**Protanomalous** – an anomalous observer who requires more red light from three primaries to match a long wavelength (“red”) test light than a normal. These observers are not truly colour blind. They are “red” weak.

**Pseudo-isochromatic plates** – printed dots are used to form differently coloured foreground figures (usually numerals) and background fields

to screen for abnormal colour discrimination. The tests rely on colour confusions known to exist in colour defectives.

**Relay nucleus** – an aggregate of cells in the thalamus organised to receive information from a peripheral end organ and with very little or no processing to send the information (relay it) to a cortical receiving area. Each sensory system has at least one relay nucleus.

**Scotopisatation** – in severe colour deficiency (usually acquired) there is intrusion of rod activity during photopic (cone) viewing conditions. Sensitivity to luminance is characteristic of rod (scotopic) functioning rather than cone (photopic) functioning which would be normal for the test conditions. This is a severe breakdown in colour vision.

**Trichromat** – a normal observer defined by the ability to match any spectral hue with a mixture of “red”, “green” and “blue” primaries. Normative data indicate the normal range of intensities for the match. Anomalous observers use greater amounts of one of the primaries to effect a match.

**Tritanomalous** – an anomalous observer who requires more “blue” light from three primaries to match a short wavelength “blue” test light than a normal. These observers are not truly colour blind. They are “blue” weak.

**Unique hue** – a hue whose colour appearance does not change with brightness. There are “yellow”, “green”, and “blue” unique hues with corresponding wavelengths of ca. 576.6, 517.5 and 468.3 nanometers, respectively.

## REPORT DOCUMENTATION PAGE

<b>1. Recipient's Reference</b>	<b>2. Originator's References</b> RTO-TR-016 AC/323(HFM-012)TP/6	<b>3. Further Reference</b> ISBN 92-837-1026-6	<b>4. Security Classification of Document</b> UNCLASSIFIED/ UNLIMITED
<b>5. Originator</b> Research and Technology Organization North Atlantic Treaty Organization BP 25, 7 rue Ancelle, F-92201 Neuilly-sur-Seine Cedex, France			
<b>6. Title</b> Operational Colour Vision in the Modern Aviation Environment			
<b>7. Presented at/sponsored by</b> the Human Factors and Medicine Panel (HFM) of RTO.			
<b>8. Author(s)/Editor(s)</b> Multiple			<b>9. Date</b> March 2001
<b>10. Author's/Editor's Address</b> Multiple			<b>11. Pages</b> 172
<b>12. Distribution Statement</b> There are no restrictions on the distribution of this document. Information about the availability of this and other RTO unclassified publications is given on the back cover.			
<b>13. Keywords/Descriptors</b>			
Colour vision		Visual perception	
Aeronautics		Display devices	
Tests		Aptitude tests	
Human factors engineering		Colour displays	
<b>14. Abstract</b>			
<p>In the past, standards and procedures for the examination of colour vision were based on red, green and white colour signals, together with the beacons associated with traditional navigational aids, originally developed for maritime or rail transport and subsequently adapted to the aeronautical environment. Many of these systems are still in service today.</p> <p>The role of colour in the military environment has been considerably extended, with the whole of the spectrum sometimes being used, rather than just a few limited colours. The visual requirements associated with this proliferation of colours call into question not only operational or ergonomical colour choices but also the procedures used to test professional colour sense. This can no longer be based solely on red, green and white discrimination or on screening for congenital masculine defective colour vision. Colour deficiencies of various origins are frequent and affect men and women to an equal extent. They affect both red and green vision and blue and yellow vision, which can be problematic when using modern day electronic displays. Finally, multiple filters can be placed between the outside world and the operator's eyes so as to protect him from high intensity light, lasers etc. These protective devices can themselves cause modification of colour vision, thereby interfering with the task to be carried out.</p> <p>What, then, is the latest data available on colour perception? How, and with what equipment or procedures can we test professional colour sense rather than colour vision anomalies? These two questions illustrate in part the purpose of the explanations and the scientific and technical bases provided in this document.</p>			

**This page has been deliberately left blank**



**Page intentionnellement blanche**



RESEARCH AND TECHNOLOGY ORGANIZATION

BP 25 • 7 RUE ANCELLE

F-92201 NEUILLY-SUR-SEINE CEDEX • FRANCE

Télécopie 0(1)55.61.22.99 • E-mail mailbox@rta.nato.int

DIFFUSION DES PUBLICATIONS

RTO NON CLASSIFIEES

L'Organisation pour la recherche et la technologie de l'OTAN (RTO), détient un stock limité de certaines de ses publications récentes, ainsi que de celles de l'ancien AGARD (Groupe consultatif pour la recherche et les réalisations aérospatiales de l'OTAN). Celles-ci pourront éventuellement être obtenues sous forme de copie papier. Pour de plus amples renseignements concernant l'achat de ces ouvrages, adressez-vous par lettre ou par télécopie à l'adresse indiquée ci-dessus. Veuillez ne pas téléphoner.

Des exemplaires supplémentaires peuvent parfois être obtenus auprès des centres nationaux de distribution indiqués ci-dessous. Si vous souhaitez recevoir toutes les publications de la RTO, ou simplement celles qui concernent certains Panels, vous pouvez demander d'être inclus sur la liste d'envoi de l'un de ces centres.

Les publications de la RTO et de l'AGARD sont en vente auprès des agences de vente indiquées ci-dessous, sous forme de photocopie ou de microfiche. Certains originaux peuvent également être obtenus auprès de CASI.

## CENTRES DE DIFFUSION NATIONAUX

## ALLEMAGNE

Streitkräfteamt / Abteilung III  
Fachinformationszentrum der  
Bundeswehr, (FIZBw)  
Friedrich-Ebert-Allee 34  
D-53113 Bonn

## BELGIQUE

Coordinateur RTO - VSL/RTO  
Etat-Major de la Force Aérienne  
Quartier Reine Elisabeth  
Rue d'Evère, B-1140 Bruxelles

## CANADA

Directeur - Recherche et développement -  
Communications et gestion de  
l'information - DRDCGI 3  
Ministère de la Défense nationale  
Ottawa, Ontario K1A 0K2

## DANEMARK

Danish Defence Research Establishment  
Ryvangs Allé 1, P.O. Box 2715  
DK-2100 Copenhagen Ø

## ESPAGNE

INTA (RTO/AGARD Publications)  
Carretera de Torrejón a Ajalvir, Pk.4  
28850 Torrejón de Ardoz - Madrid

## ETATS-UNIS

NASA Center for AeroSpace  
Information (CASI)  
Parkway Center  
7121 Standard Drive  
Hanover, MD 21076-1320

## FRANCE

O.N.E.R.A. (ISP)  
29, Avenue de la Division Leclerc  
BP 72, 92322 Châtillon Cedex

## GRECE (Correspondant)

Hellenic Ministry of National  
Defence  
Defence Industry Research &  
Technology General Directorate  
Technological R&D Directorate  
D.Soutsou 40, GR-11521, Athens

## HONGRIE

Department for Scientific  
Analysis  
Institute of Military Technology  
Ministry of Defence  
H-1525 Budapest P O Box 26

## ISLANDE

Director of Aviation  
c/o Flugrad  
Reykjavik

## ITALIE

Centro di Documentazione  
Tecnico-Scientifica della Difesa  
Via XX Settembre 123a  
00187 Roma

## LUXEMBOURG

Voir Belgique

## NORVEGE

Norwegian Defence Research  
Establishment  
Attn: Biblioteket  
P.O. Box 25, NO-2007 Kjeller

## PAYS-BAS

NDRCC  
DGM/DWOO  
P.O. Box 20701  
2500 ES Den Haag

## POLOGNE

Chief of International Cooperation  
Division  
Research & Development Department  
218 Niepodleglosci Av.  
00-911 Warsaw

## PORTUGAL

Estado Maior da Força Aérea  
SDFA - Centro de Documentação  
Alfragide  
P-2720 Amadora

## REPUBLIQUE TCHEQUE

Distribuční a informační středisko R&T  
VTÚL a PVO Praha  
Mladoboleslavská ul.  
197 06 Praha 9-Kbely AFB

## ROYAUME-UNI

Defence Research Information Centre  
Kentigern House  
65 Brown Street  
Glasgow G2 8EX

## TURQUIE

Millî Savunma Başkanlığı (MSB)  
ARGE Dairesi Başkanlığı (MSB)  
06650 Bakanlıklar - Ankara

## AGENCES DE VENTE

## NASA Center for AeroSpace

Information (CASI)  
Parkway Center  
7121 Standard Drive  
Hanover, MD 21076-1320  
Etats-Unis

## The British Library Document

Supply Centre  
Boston Spa, Wetherby  
West Yorkshire LS23 7BQ  
Royaume-Uni

## Canada Institute for Scientific and

Technical Information (CISTI)  
National Research Council  
Document Delivery  
Montreal Road, Building M-55  
Ottawa K1A 0S2, Canada

Les demandes de documents RTO ou AGARD doivent comporter la dénomination "RTO" ou "AGARD" selon le cas, suivie du numéro de série (par exemple AGARD-AG-315). Des informations analogues, telles que le titre et la date de publication sont souhaitables. Des références bibliographiques complètes ainsi que des résumés des publications RTO et AGARD figurent dans les journaux suivants:

## Scientific and Technical Aerospace Reports (STAR)

STAR peut être consulté en ligne au localisateur de  
ressources uniformes (URL) suivant:  
<http://www.sti.nasa.gov/Pubs/star/Star.html>

STAR est édité par CASI dans le cadre du programme  
NASA d'information scientifique et technique (STI)  
STI Program Office, MS 157A  
NASA Langley Research Center  
Hampton, Virginia 23681-0001  
Etats-Unis

## Government Reports Announcements &amp; Index (GRA&amp;I)

publié par le National Technical Information Service  
Springfield  
Virginia 2216  
Etats-Unis  
(accessible également en mode interactif dans la base de  
données bibliographiques en ligne du NTIS, et sur CD-ROM)



Imprimé par St-Joseph Ottawa/Hull  
(Membre de la Corporation St-Joseph)

45, boul. Sacré-Cœur, Hull (Québec), Canada J8X 1C6



## RESEARCH AND TECHNOLOGY ORGANIZATION

BP 25 • 7 RUE ANCELLE

F-92201 NEUILLY-SUR-SEINE CEDEX • FRANCE

Telefax 0(1)55.61.22.99 • E-mail mailbox@rta.nato.int

## DISTRIBUTION OF UNCLASSIFIED

## RTO PUBLICATIONS

NATO's Research and Technology Organization (RTO) holds limited quantities of some of its recent publications and those of the former AGARD (Advisory Group for Aerospace Research & Development of NATO), and these may be available for purchase in hard copy form. For more information, write or send a telefax to the address given above. **Please do not telephone.**

Further copies are sometimes available from the National Distribution Centres listed below. If you wish to receive all RTO publications, or just those relating to one or more specific RTO Panels, they may be willing to include you (or your organisation) in their distribution.

RTO and AGARD publications may be purchased from the Sales Agencies listed below, in photocopy or microfiche form. Original copies of some publications may be available from CASI.

## NATIONAL DISTRIBUTION CENTRES

## BELGIUM

Coordinateur RTO - VSL/RTO  
Etat-Major de la Force Aérienne  
Quartier Reine Elisabeth  
Rue d'Evère, B-1140 Bruxelles

## CANADA

Director Research & Development  
Communications & Information  
Management - DRDCIM 3  
Dept of National Defence  
Ottawa, Ontario K1A 0K2

## CZECH REPUBLIC

Distribuční a informační středisko R&T  
VTÚL a PVO Praha  
Mladoboleslavská ul.  
197 06 Praha 9-Kbely AFB

## DENMARK

Danish Defence Research  
Establishment  
Ryvangs Allé 1, P.O. Box 2715  
DK-2100 Copenhagen Ø

## FRANCE

O.N.E.R.A. (ISP)  
29 Avenue de la Division Leclerc  
BP 72, 92322 Châtillon Cedex

## GERMANY

Streitkräfteamt / Abteilung III  
Fachinformationszentrum der  
Bundeswehr, (FIZBw)  
Friedrich-Ebert-Allee 34  
D-53113 Bonn

## GREECE (Point of Contact)

Hellenic Ministry of National  
Defence  
Defence Industry Research &  
Technology General Directorate  
Technological R&D Directorate  
D.Soutsou 40, GR-11521, Athens

## HUNGARY

Department for Scientific  
Analysis  
Institute of Military Technology  
Ministry of Defence  
H-1525 Budapest P O Box 26

## ICELAND

Director of Aviation  
c/o Flugrad  
Reykjavik

## ITALY

Centro di Documentazione  
Tecnico-Scientifica della Difesa  
Via XX Settembre 123a  
00187 Roma

## LUXEMBOURG

See Belgium

## NETHERLANDS

NDRCC  
DGM/DWOO  
P.O. Box 20701  
2500 ES Den Haag

## NORWAY

Norwegian Defence Research  
Establishment  
Attn: Biblioteket  
P.O. Box 25, NO-2007 Kjeller

## POLAND

Chief of International Cooperation  
Division  
Research & Development  
Department  
218 Niepodleglosci Av.  
00-911 Warsaw

## PORTUGAL

Estado Maior da Força Aérea  
SDFA - Centro de Documentação  
Alfragide  
P-2720 Amadora

## SPAIN

INTA (RTO/AGARD Publications)  
Carretera de Torrejón a Ajalvir, Pk.4  
28850 Torrejón de Ardoz - Madrid

## TURKEY

Millî Savunma Başkanlığı (MSB)  
ARGE Dairesi Başkanlığı (MSB)  
06650 Bakanlıklar - Ankara

## UNITED KINGDOM

Defence Research Information  
Centre  
Kentigern House  
65 Brown Street  
Glasgow G2 8EX

## UNITED STATES

NASA Center for AeroSpace  
Information (CASI)  
Parkway Center  
7121 Standard Drive  
Hanover, MD 21076-1320

## SALES AGENCIES

NASA Center for AeroSpace  
Information (CASI)

Parkway Center  
7121 Standard Drive  
Hanover, MD 21076-1320  
United States

The British Library Document  
Supply Centre

Boston Spa, Wetherby  
West Yorkshire LS23 7BQ  
United Kingdom

Canada Institute for Scientific and  
Technical Information (CISTI)

National Research Council  
Document Delivery  
Montreal Road, Building M-55  
Ottawa K1A 0S2, Canada

Requests for RTO or AGARD documents should include the word 'RTO' or 'AGARD', as appropriate, followed by the serial number (for example AGARD-AG-315). Collateral information such as title and publication date is desirable. Full bibliographical references and abstracts of RTO and AGARD publications are given in the following journals:

**Scientific and Technical Aerospace Reports (STAR)**

STAR is available on-line at the following uniform resource locator:

<http://www.sti.nasa.gov/Pubs/star/Star.html>

STAR is published by CASI for the NASA Scientific and Technical Information (STI) Program  
STI Program Office, MS 157A  
NASA Langley Research Center  
Hampton, Virginia 23681-0001  
United States

**Government Reports Announcements & Index (GRA&I)**

published by the National Technical Information Service  
Springfield  
Virginia 22161  
United States  
(also available online in the NTIS Bibliographic Database or on CD-ROM)



Printed by St. Joseph Ottawa/Hull  
(A St. Joseph Corporation Company)  
45 Sacré-Cœur Blvd., Hull (Québec), Canada J8X 1C6